

SIEMENS



SINAMICS S120 Chassis Format Converter Units
SINAMICS S120 Cabinet Modules
SINAMICS S150 Converter Cabinet Units

SINAMICS Drives

Catalog
D 21.3

Edition
2015

Related catalogs

<p>SINAMICS G130 D 11 Drive Converter Chassis Units SINAMICS G150 Drive Converter Cabinet Units</p> <p>E86060-K5511-A101-A6-7600</p>		<p>Industrial Controls IC 10 SIRIUS</p> <p>PDF (E86060-K1010-A101-A6-7600)</p>	
<p>SINAMICS GM150/SINAMICS SM150 D 12 Medium-Voltage Converters</p> <p>E86060-K5512-A101-A3-7600</p>		<p>Industrial Communication IK PI SIMATIC NET</p> <p>E86060-K6710-A101-B8-7600</p>	
<p>SINAMICS G180 D 18.1 Converters – Compact Units, Cabinet Systems, Cabinet Units Air-Cooled and Liquid-Cooled</p> <p>E86060-K5518-A111-A2-7600</p>		<p>Low-Voltage Power Distribution and Electrical Installation Technology LV 10 SENTRON • SIVACON • ALPHA Protection, Switching, Measuring and Monitoring Devices, Switchboards and Distribution Systems Print (E86060-K8280-A101-A3-7600)</p>	
<p>Motion Control Drives D 31 SINAMICS Inverters for Single-Axis Drives and SIMOTICS Motors</p> <p>E86060-K5531-A101-A2-7600</p>		<p>Products for Automation and Drives CA 01 Interactive Catalog, DVD</p> <p>E86060-D4001-A510-D6-7600</p>	
<p>SINAMICS Drives D 35 SINAMICS G120P and SINAMICS G120P Cabinet pump, fan, compressor converters</p> <p>E86060-K5535-A101-A1-7600</p>		<p>Industry Mall Information and Ordering Platform in the Internet:</p> <p>www.siemens.com/industrymall</p>	
<p>Motion Control PM 21 SIMOTION, SINAMICS S120 & SIMOTICS Equipment for Production Machines</p> <p>E86060-K4921-A101-A3-7600</p>			
<p>SIMOTICS GP, SD, XP, DP D 81.1 Low-Voltage Motors Type series 1LE1, 1MB1 and 1PC1 Frame sizes 71 to 315 Power range 0.18 to 200 kW E86060-K5581-A111-A8-7600</p>			
<p>SIMOTICS FD D 81.8 Low-Voltage Motors Frame sizes 315 to 450 Power range 200 to 1800 kW E86060-K5581-A181-A4-7600</p>			
<p>LOHER Low-Voltage Motors D 83.1 Type series 1MD5, 1PS0, 1PS1, 1PS4 and 1PS5 Frame sizes 71 to 500 Power range 0.25 to 1400 kW E86060-K5583-A111-A2-7600</p>			

The Engineering Manual

SINAMICS Low Voltage Engineering Manual

Engineering Manual for

- SINAMICS G130 Drive Converter Chassis Units,
- SINAMICS G150 Drive Converter Cabinet Units,
- SINAMICS S120 Chassis Format Units,
- SINAMICS S120 Cabinet Modules,
- SINAMICS S150 Converter Cabinet Units



This manual offers users comprehensive support with the configuring of drives and associated system components.

The first three chapters are devoted primarily to the fundamental physical principles of variable-speed electric drives and include EMC Installation Guidelines as well as general system descriptions and planning information which relate to all products in the SINAMICS range.

The other chapters then discuss in detail questions relating to the dimensioning of drives with converters of specific types as well as the selection of suitable motors.

Note:
The manual is not available in hard copy form, but only as an electronic file in PDF format.

SINAMICS S120 Chassis Format Converter Units

SINAMICS S120 Cabinet Modules

SINAMICS S150 Converter Cabinet Units

SINAMICS Drives



Catalog D 21.3 · 2015

Supersedes:

Catalog D 21.3 · 2014 (PDF)

Catalog D 21.3 · 2011 and

Revision from December 2011 to catalog D 21.3 · 2011

Refer to the Industry Mall for current updates of this catalog:

www.siemens.com/industrymall

The products contained in this catalog can also be found in the Interactive Catalog CA 01.

Article No.: E86060-D4001-A510-D6-7600

Please contact your local Siemens branch.

© Siemens AG 2016



The products and systems described in this catalog are manufactured/distributed under application of a certified quality management system in accordance with DIN EN ISO 9001 (Certified Registration No. 002241 QM UM). The certificate is recognized by all IQNet countries.

System Overview	1
Highlights	2
SINAMICS S120 Chassis Format Converter Units 75 kW to 5700 kW	3
SINAMICS S120 Cabinet Modules 4.8 kW to 5700 kW	4
SINAMICS S150 Converter Cabinet Units 75 kW to 1200 kW	5
Tools and Engineering	6
Services and Documentation	7
Appendix	8

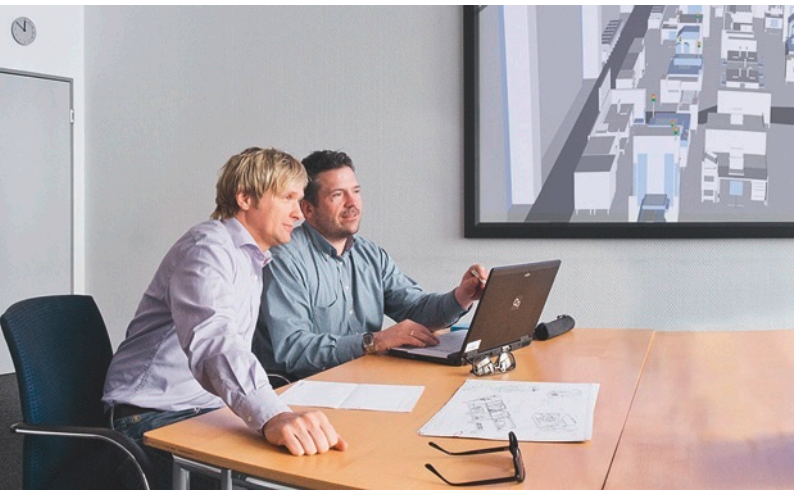



Answers for industry.

Integrated technologies, vertical market expertise and services for greater productivity, energy efficiency, and flexibility.

Siemens is the world's leading supplier of innovative and environmentally friendly products and solutions for industrial companies. End-to-end automation technology and industrial software, solid market expertise, and technology-based services are the levers we use to increase our customers' productivity, efficiency and flexibility.

We consistently rely on integrated technologies and, thanks to our bundled portfolio, we can respond more quickly and flexibly to our customers' wishes. With our globally unmatched range of automation technology, industrial control and drive technology as well as industrial software, we equip companies with exactly what they need over their entire value chain – from product design and development to production, sales and service. Our industrial customers benefit from our comprehensive portfolio, which is tailored to their market and their needs.

Market launch times can be reduced by up to 50% due to the combination of powerful automation technology and industrial software. At the same time, the costs for energy or waste water for a manufacturing company can be reduced significantly. In this way, we increase our customers' competitive strength and make an important contribution to environmental protection with our energy-efficient products and solutions.

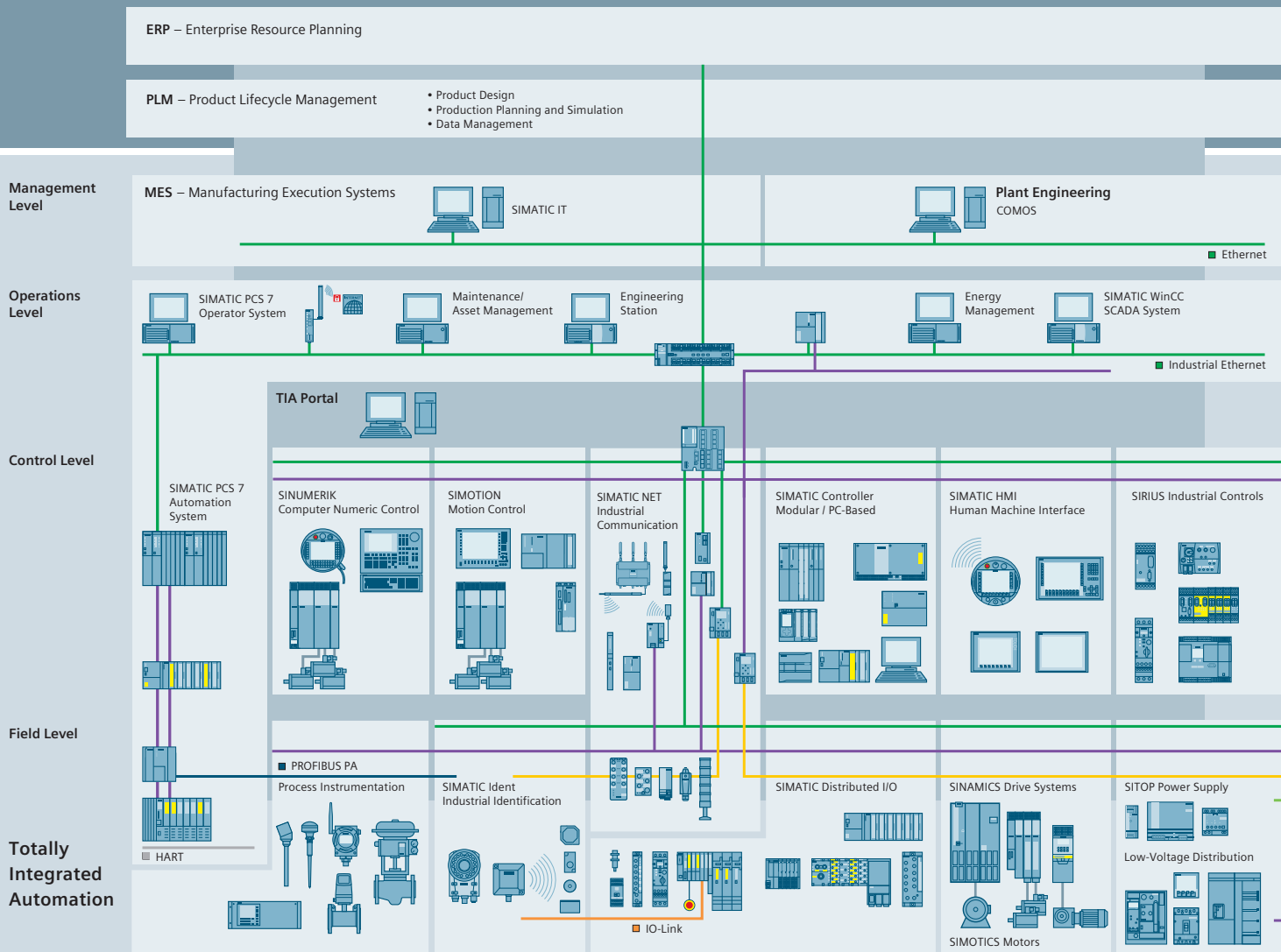

Efficient automation starts with efficient engineering.

Totally Integrated Automation: Efficiency driving productivity.

Efficient engineering is the first step toward better production that is faster, more flexible, and more intelligent. With all components interacting efficiently, Totally Integrated Automation (TIA) delivers enormous time savings right from the engineering phase. The result is lower costs, faster time-to-market, and greater flexibility.

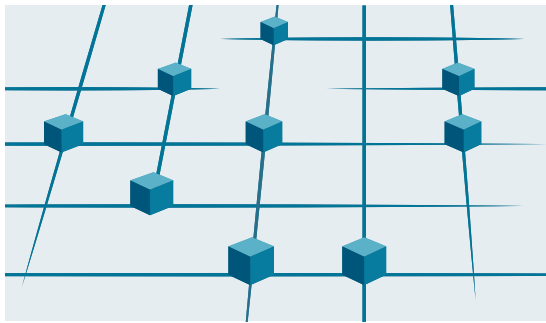

Totally Integrated Automation
Efficient interoperability of all automation components



- PROFINET
- Industrial Ethernet
- PROFIBUS
- AS-Interface
- KNX GAMMA instabus

Totally
Integrated
Power

A unique complete approach for all industries

As one of the world's leading automation suppliers, Siemens provides an integrated, comprehensive portfolio for all requirements in process and manufacturing industries. All components are mutually compatible and system-tested. This ensures that they reliably perform their tasks in industrial use and interact efficiently, and that each automation solution can be implemented with little time and effort based on standard products. The integration of many separate individual engineering tasks into a single engineering environment, for example, provides enormous time and cost savings.

With its comprehensive technology and industry-specific expertise, Siemens is continuously driving progress in manufacturing industries – and Totally Integrated Automation plays a key role.

Totally Integrated Automation creates real value added in all automation tasks, especially for:

- **Integrated engineering**
Consistent, comprehensive engineering throughout the entire product development and production process
- **Industrial data management**
Access to all important data occurring in productive operation – along the entire value chain and across all levels
- **Industrial communication**
Integrated communication based on international cross-vendor standards that are mutually compatible
- **Industrial security**
Systematic minimization of the risk of an internal or external attack on plants and networks
- **Safety Integrated**
Reliable protection of personnel, machinery, and the environment thanks to seamless integration of safety technologies into the standard automation

Making things right with Totally Integrated Automation

Totally Integrated Automation, industrial automation from Siemens, stands for the efficient interoperability of all automation components. The open system architecture covers the entire production process and is based on end-to-end shared characteristics: consistent data management, global standards, and uniform hardware and software interfaces.

Totally Integrated Automation lays the foundation for comprehensive optimization of the production process:

- Time and cost savings due to efficient engineering
- Minimized downtime due to integrated diagnostic functions
- Simplified implementation of automation solutions due to global standards
- Better performance due to interoperability of system-tested components



Totally Integrated Power

We bring power to the point – safely and reliably.

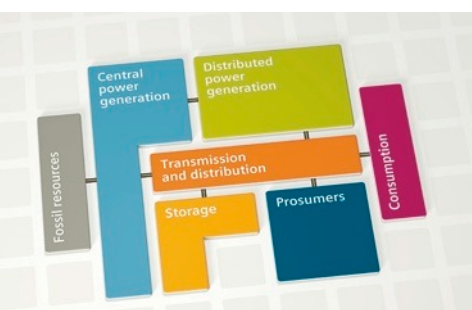

Comprehensive answers for power distribution in complex energy systems – from Siemens

Efficient, reliable, safe: These are the demands placed on electrification and especially power distribution. And our answer – for all application areas of the energy system – is Totally Integrated Power (TIP). It's based on our comprehensive range of products, systems, and solutions for low and medium voltage, rounded out by our support throughout the entire lifecycle – from planning with our own software tools to installation, operation, and services.

Smart interfaces allow linking to industrial or building automation, making it possible to fully exploit all the optimization potential of an integrated solution. This is how we provide our customers around the world with answers to their challenges. With highly efficient, reliable, and safe power distribution, we lay the foundation for sustainable infrastructure and cities, buildings, and industrial plants. We bring power to the point – wherever and whenever it is needed.

More information: www.siemens.com/tip

Totally Integrated Power offers more:

- **Consistency:**
For simplified plant engineering and commissioning as well as smooth integration into automation solutions for building or production processes
- **One-stop-shop:**
A reliable partner with a complete portfolio for the entire process and lifecycle – from the initial idea to after-sales service
- **Safety:**
A comprehensive range of protection components for personnel safety and line and fire protection, safety by means of type testing
- **Reliability:**
A reliable partner who works with customers to develop long-lasting solutions that meet the highest quality standards
- **Efficiency:**
Bringing power to the point means greater plant availability and maximum energy efficiency in power distribution
- **Flexibility:**
End-to-end consistency and modular design of Totally Integrated Power for any desired expansions and adaptation to future requirements
- **Advanced technology:**
Reliable power distribution especially for applications in which supply is critical, continuous refinement of the technology

Challenges are our speciality

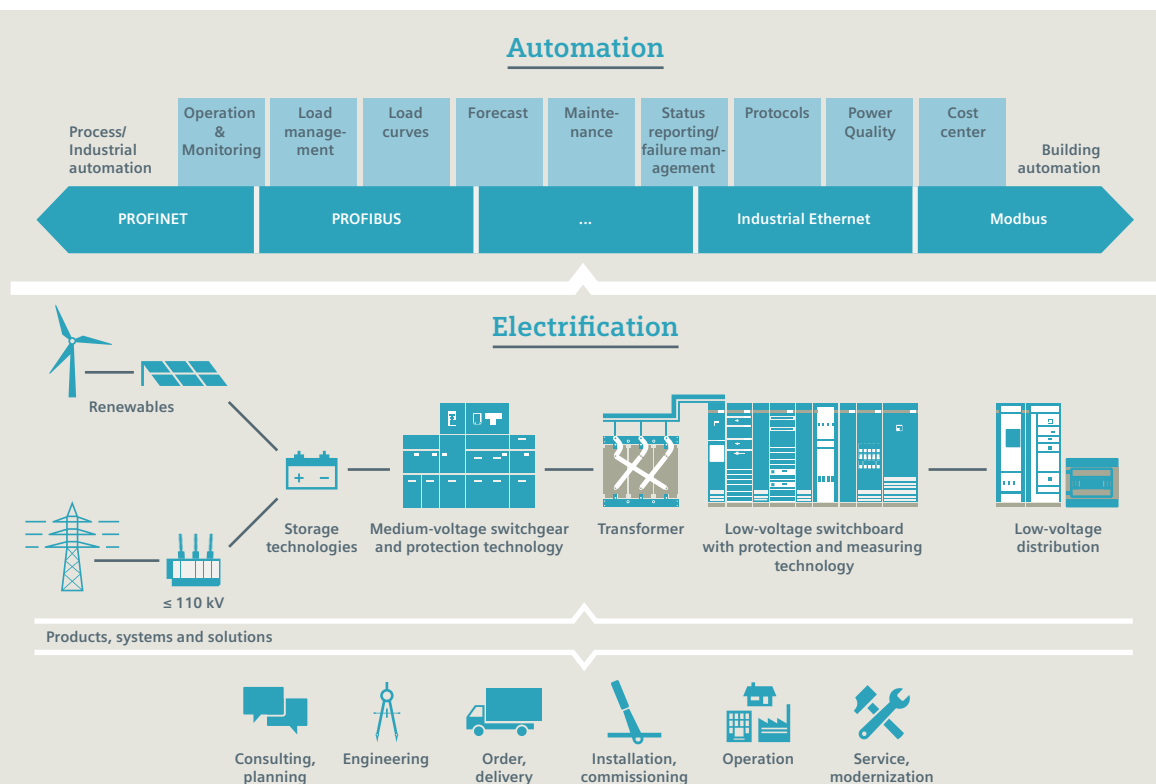

Integrated Drive Systems

Faster on the market and in the black with Integrated Drive Systems

SINAMICS is an important element of a Siemens Integrated Drive System, contributing significantly to increased efficiency, productivity, and availability in industrial production processes.

Integrated Drive Systems are Siemens' trendsetting answer to the high degree of complexity that characterizes drive and automation technology today. The world's only true one-stop solution for entire drive systems is characterized in particular by its threefold integration: Horizontal, vertical,

and lifecycle integration ensure that every drive system component fits seamlessly into the whole system, into any automation environment, and even into the entire lifecycle of a plant.

The outcome is an optimal workflow – from engineering all the way to service that entails more productivity, increased efficiency, and better availability. That's how Integrated Drive Systems reduce time to market and time to profit.

Horizontal integration

Integrated drive portfolio: The core elements of a fully integrated drive portfolio are frequency converters, motors, couplings, and gear units. At Siemens, they're all available from a single source. Perfectly integrated, perfectly interacting. For all power and performance classes. As standard solutions or fully customized. No other player in the market can offer a comparable portfolio. Moreover, all Siemens drive components are perfectly matched, so they are optimally interacting.

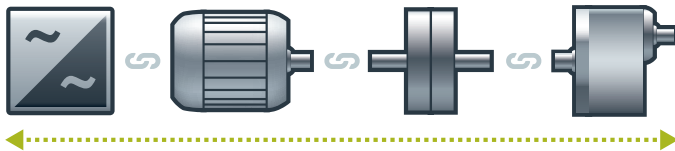

You can boost the availability of your application or plant to up to

99%*

*e.g., conveyor application

Vertical integration

Thanks to **vertical integration**, the complete drive train is seamlessly integrated in the entire automation environment – an important prerequisite for production with maximum value added. Integrated Drive Systems are part of Totally Integrated Automation (TIA), which means that they are perfectly embedded into the system architecture of the entire industrial production process. This enables optimal processes through maximum communication and control.

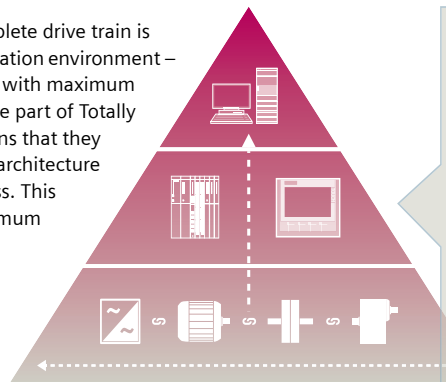

With TIA Portal you can cut your engineering time by up to

30%

Lifecycle integration

Lifecycle integration adds the factor of time: Software and service are available for the entire lifecycle of an Integrated Drive System. That way, important optimization potential for maximum productivity, increased efficiency, and highest availability can be leveraged throughout the system's lifecycle – from planning, design, and engineering to operation, maintenance, and all the way even to modernization.

With Integrated Drive Systems, assets become important success factors. They ensure shorter time to market, maximum productivity and efficiency in operation, and shorter time to profit.

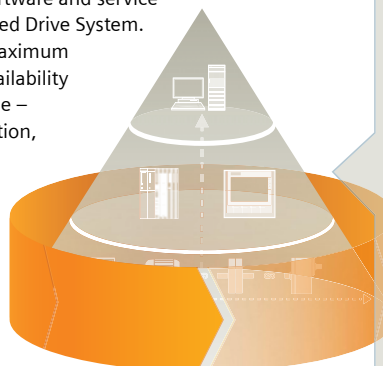

With Integrated Drive Systems you can reduce your maintenance costs by up to

15%

System Overview



1/2	The SINAMICS drive family
1/2	Integration in automation
1/2	Applications
1/3	Energy efficiency
1/4	Variants
1/4	Platform concept
1/4	Quality management according to EN ISO 9001
1/6	System properties
1/6	Application areas
1/7	Drive selection
1/7	SINAMICS selection guide – typical applications
1/8	SIMOTICS motors
1/9	SINAMICS S120
	The flexible, modular drive system for demanding drive tasks
1/12	SINAMICS S150
	The drive solution for demanding single-motor drives

System Overview

The SINAMICS drive family

Overview

Integration in automation

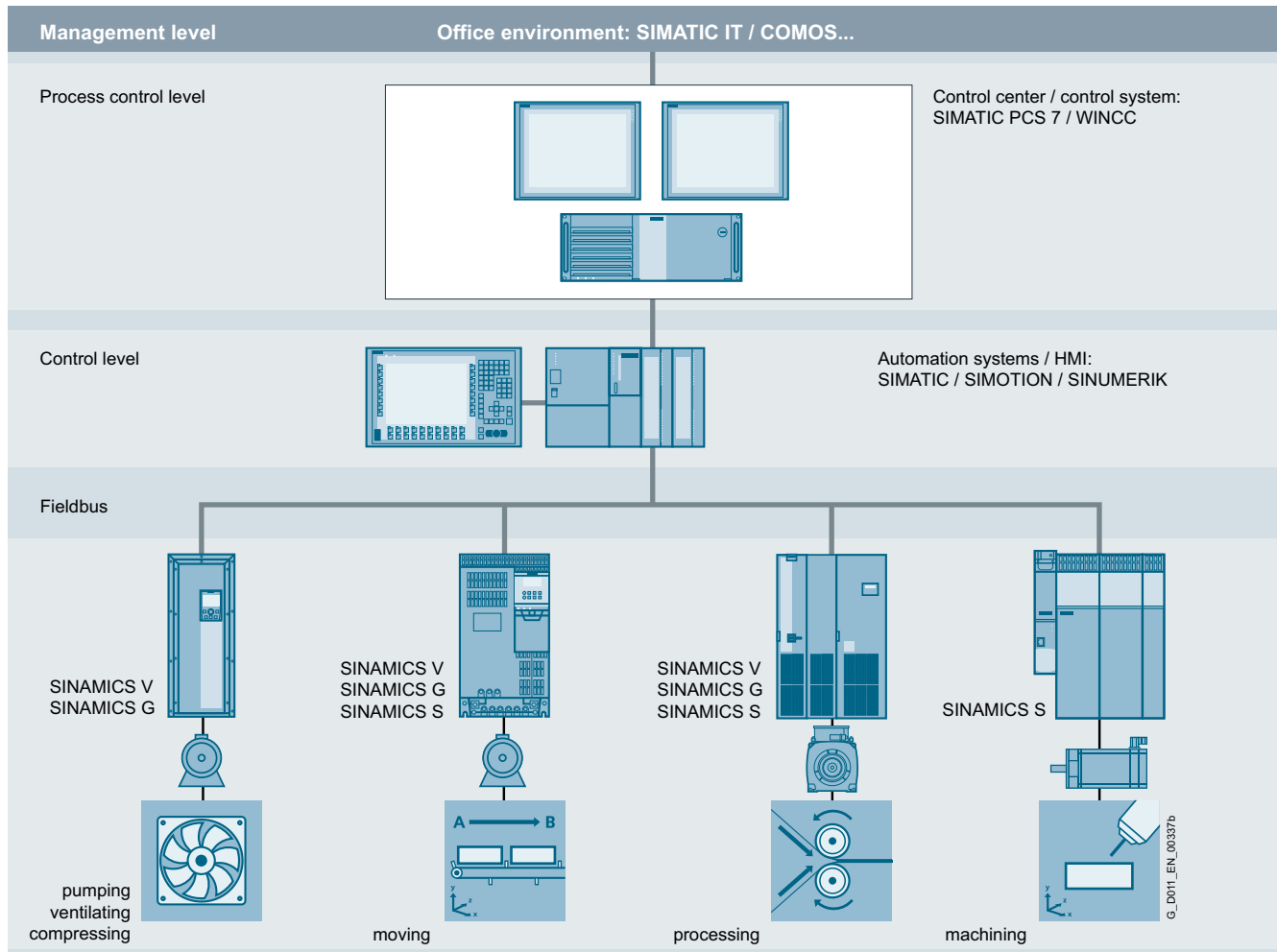

SINAMICS in the automation environment

Totally Integrated Automation and communication

SINAMICS is an integral component of Siemens Totally Integrated Automation. The integrated and seamless SINAMICS system covering engineering, data management, and communication at the automation level ensures solutions with low associated costs in conjunction with the SIMATIC, SIMOTION, and SINUMERIK control systems.

Depending on the application, the appropriate converter can be selected and incorporated in the automation concept. With this in mind, the converters are clearly subdivided into their different applications. A wide range of communication options (depending on the drive type) are available for establishing a communication link to the automation system:

- PROFINET
- EtherNet/IP
- PROFIBUS
- AS-Interface
- USS
- CANopen
- Modbus RTU
- BacNet MS/TP

Applications

SINAMICS is the comprehensive family of drives from Siemens designed for machine and plant engineering applications. SINAMICS offers solutions for all drive tasks:

- Simple pump and fan applications in the process industry
- Demanding single drives in centrifuges, presses, extruders, elevators, as well as conveyor and transport systems
- Drive line-ups in textile, plastic film, and paper machines as well as in rolling mill plants
- High-precision servo drives for the manufacture of wind turbines
- Highly dynamic servo drives for machine tools, as well as packaging and printing machines

Overview (continued)

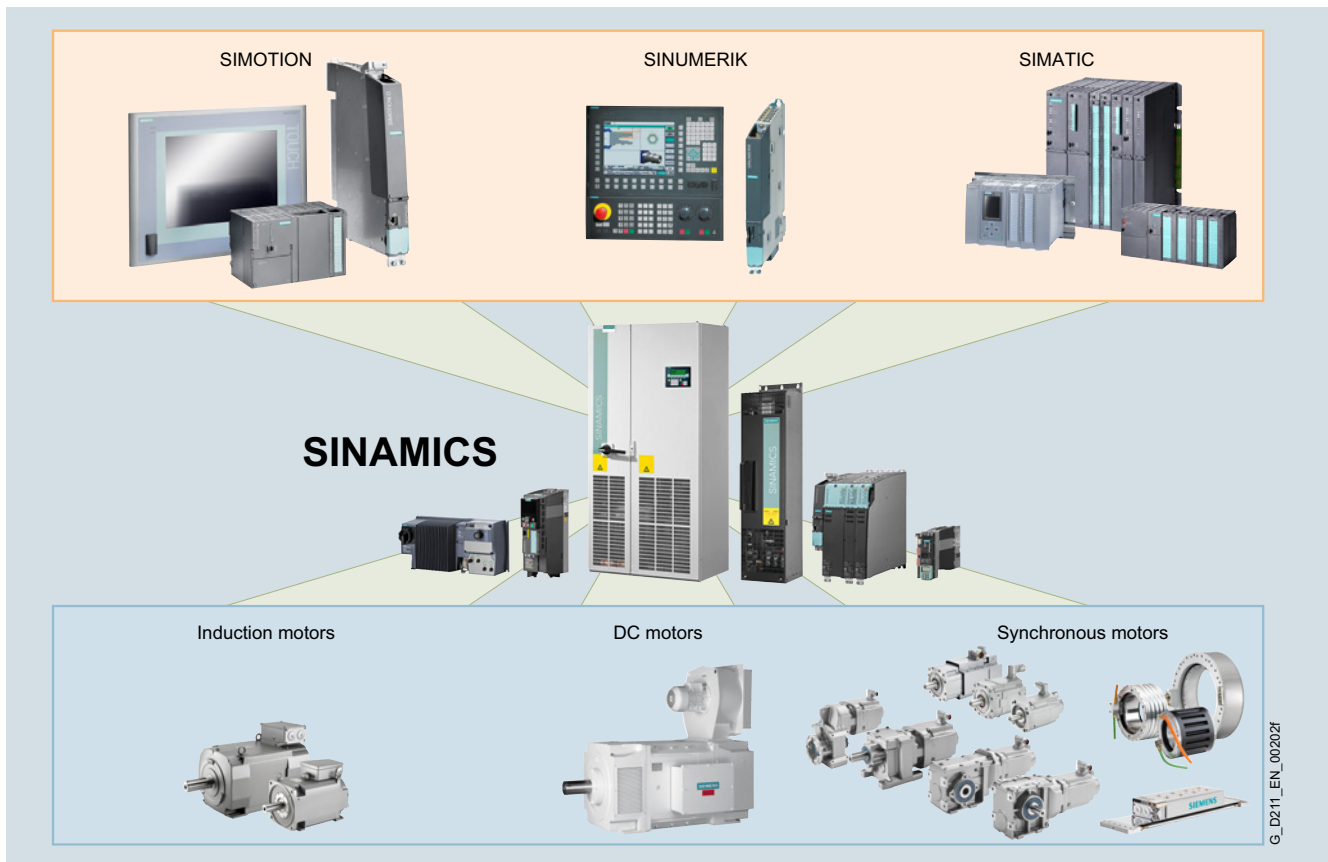

SINAMICS as part of the Siemens modular automation system

Innovative, energy-efficient and reliable drive systems and applications as well as services for the entire drive train

The solutions for drive technology place great emphasis on the highest productivity, energy efficiency and reliability for all torque ranges, performance and voltage classes.

Siemens offers not only the right innovative variable frequency drive for every drive application, but also a wide range of energy-efficient low voltage motors, geared motors, explosion-protected motors and high-voltage motors for combination with SINAMICS.

Furthermore, Siemens supports its customers with global pre-sales and after-sales services, with over 295 service points in 130 countries – and with special services e.g. application consulting or motion control solutions.

Energy efficiency

Energy management process

Efficient energy management consultancy identifies the energy flows, determines the potential for making savings and implements them with focused activities.

Almost two thirds of the industrial power requirement is from electric motors. This makes it all the more important to use drive technology permitting energy consumption to be reduced effectively even in the configuration phase, and consequently to optimize plant availability and process stability. With SINAMICS, Siemens offers powerful energy efficient solutions which, depending on the application, enable a significant reduction in electricity costs.

Up to 70 % potential for savings using variable speed operation

SINAMICS enables great potential for savings to be realized by controlling the motor speed. In particular, huge potential savings can be recovered from pumps, fans and compressors which are operated with mechanical throttle and valves. Here, changing to variable-speed drives brings enormous economic advantages. In contrast to mechanical control systems, the power consumption at partial load operation is always immediately adjusted to the demand at that time. So energy is no longer wasted, permitting savings of up to 60 % – in exceptional cases even up to 70 %. Variable-speed drives also offer clear advantages over mechanical control systems when it comes to maintenance and repair. Current spikes when powering up the motor and strong torque surges become things of the past – and the same goes for pressure waves in pipelines, cavitation or vibrations which cause sustainable damage to the plant. Smooth starting and ramp-down relieve the load on the mechanical system, ensuring a significantly longer service life of the entire drive train.

Regenerative feedback of braking energy

In conventional drive systems, the energy produced during braking is converted to heat using braking resistors. Energy produced during braking is efficiently recovered to the supply system by versions of SINAMICS G and SINAMICS S inverters with regenerative feedback capability and these devices do not therefore need a braking resistor. This permits up to 60 % of the energy requirement to be saved, e.g. in lifting applications. Energy which can be reused at other locations on a machine. Furthermore, this reduced power loss simplifies the cooling of the system, enabling a more compact design.

System Overview

The SINAMICS drive family

Overview (continued)

Energy transparency in all configuration phases

Early on, in the configuration phase, the SIZER for Siemens Drives engineering tool provides information on the specific energy requirement. The energy consumption across the entire drive train is visualized and compared with different plant concepts.

Variants

Depending on the application, the SINAMICS range offers the ideal variant for any drive task.

SINAMICS in combination with energy-saving motors

Engineering integration stretches beyond the SINAMICS drive family to higher-level automation systems, and to a broad spectrum of energy-efficient motors with a wide range of performance classes, which, compared to previous motors, are able to demonstrate up to 10 % greater efficiency.

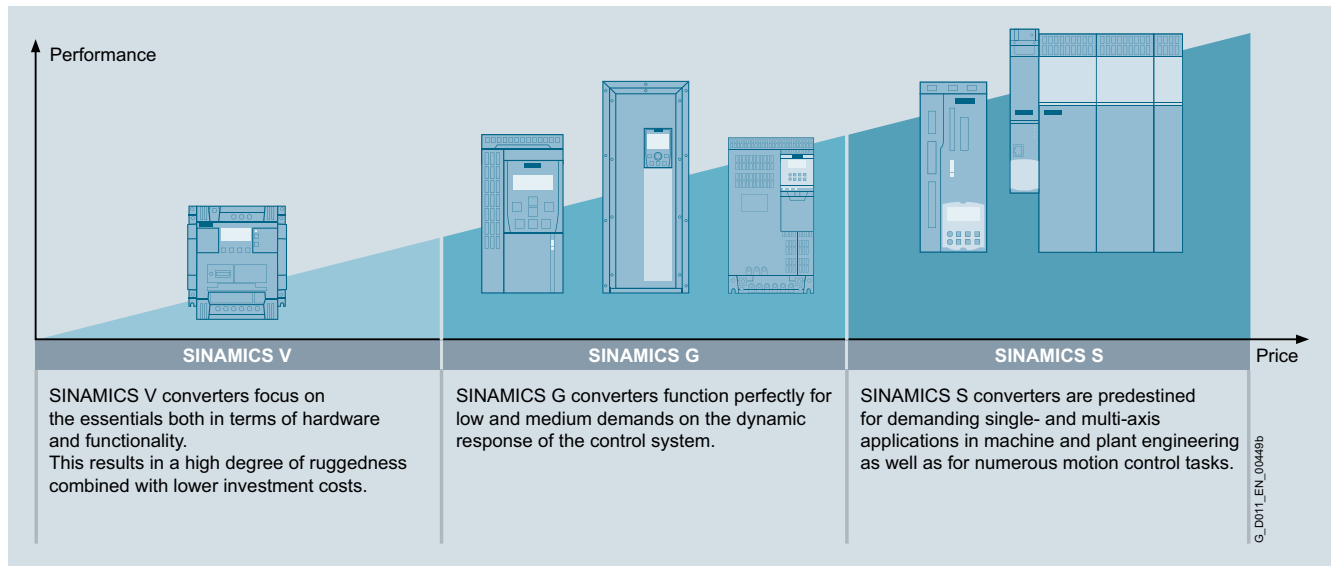

Platform concept

All SINAMICS variants are based on a platform concept. Joint hardware and software components, as well as standardized tools for dimensioning, configuration, and commissioning tasks ensure high-level integration across all components. SINAMICS handles a wide variety of drive tasks with no system gaps. The different SINAMICS variants can be easily combined with each other.









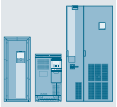
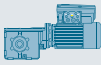

Quality management according to EN ISO 9001

SINAMICS conforms to the most exacting quality requirements. Comprehensive quality assurance measures in all development and production processes ensure a consistently high level of quality.

Of course, our quality management system is certified by an independent authority in accordance with EN ISO 9001.

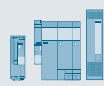
Overview (continued)

The SINAMICS drive family

Low voltage									DC voltage	Medium voltage	
Basic performance		General performance						High performance		DC applications	Applications with high outputs
											
V20	V90	G120C/G120P/ G120P Cabinet	G110D/ G120D/ G110M	G130/G150	G180	S110	S120/ S120M	S150	DCM	GH150/GH180/ GM150/SM150/ GL150/SL150/ SM120CM	
0.12 ... 30 kW	0.05 ... 7 kW	0.37 ... 630 kW	0.37 ... 7.5 kW	75 ... 2700 kW	2.2 ... 6600 kW	0.12 ... 90 kW	0.12 ... 5700 kW	75 ... 1200 kW	6 kW ... 30 MW	0.15 ... 85 MW	
Pumps, fans, compressors, conveyor belts, mixers, mills, spinning machines and textile machines	Handling machines, packaging machines, automatic assembly machines, metal forming machines, printing machines, winding and unwinding units	Pumps, fans, compressors, conveyor belts, mixers, mills, extruders, building management systems, process industry, HVAC, single-axis positioning applications in machine and plant engineering	Conveyor technology, single-axis positioning applications (G120D)	Pumps, fans, compressors, conveyor belts, mixers, mills, extruders	Sector-specific for pumps, fans, compressors, conveyor belts, extruders, mixers, mills, kneaders, centrifuges, separators	Single-axis positioning applications in machine and plant engineering	Production machines (packaging, textiles and printing machines, paper machines, plastic processing machines), machine tools, plants, process lines and rolling mills, ships and test bays	Test bays, cross cutters, centrifuges	Rolling mill drives, wire-drawing machines, extruders and kneaders, cableways and lifts, test bay drives	Pumps, fans, compressors, mixers, extruders, mills, crushers, rolling mills, conveying technology, excavators, test bays, marine drives, blast furnace fans, retrofit	
V20 Brochure	V90 Brochure	Catalogs D 31, D 35	Catalog D 31	Catalog D 11	Catalog D 18.1	Catalog D 31	Catalogs D 21.3 PM 21, NC 62	Catalog D 21.3	Catalogs D 23.1, D 23.2	Catalogs D 15.1, D 12	
Engineering tools (e.g. Drive Technology Configurator, SIZER for Siemens Drives, STARTER and SINAMICS Startdrive)											

G_D011_EN_00450e

System Overview

The SINAMICS drive family

Overview (continued)

System properties

The SINAMICS range is characterized by the following system properties:

- Standard and seamless functionality based on a platform concept
- Standardized engineering
- High degree of flexibility and combination capability
- Wide range of power ratings
- Designed for global use
- SINAMICS Safety Integrated
- Increased economic efficiency and effectiveness
- High energy efficiency
- Wide range of options when interfacing to higher-level control systems
- Totally Integrated Automation

Application areas

Tailored to suit different application areas, the SINAMICS range encompasses the following products:

AC low-voltage converters (line supply voltage < 1000 V)

- SINAMICS G110
 - The versatile drive for low power ratings
- SINAMICS G110D
 - The distributed, compact single-motor drive in a high degree of protection for basic applications
- SINAMICS G120
 - The modular single drive for low up to medium power ratings
- SINAMICS G120C
 - The compact drive with high power density
- SINAMICS G120D
 - The distributed, modular single-motor drive in a high degree of protection for sophisticated applications
- SINAMICS G120P
 - The specialist for pumps, fans, and compressors
- SINAMICS G130 and SINAMICS G150
 - The universal drive solution for high-performance single drives
- SINAMICS G180
 - The specific drive solution for the oil & gas, chemical and process industries
- SINAMICS S110
 - The basic positioning drive for single-axis applications
- SINAMICS S120
 - The flexible, modular drive system for demanding drive tasks
- SINAMICS S150
 - The drive solution for demanding single-motor drives with energy recovery

DC converter (line supply voltage < 1000 V)

- SINAMICS DCM
 - The scalable drive system for both basic and demanding applications

AC medium-voltage converters (line supply voltage > 1000 V)

- SINAMICS GM150
 - The universal drive solution for single-motor drives
- SINAMICS SM150
 - The drive solution for demanding single-motor and multi-motor drives
- SINAMICS GL150
 - The drive solution for synchronous motors up to 120 MW
- SINAMICS SL150
 - The drive solution for rotors with a high number of poles (slow speed) for the highest torques and overloads
- SINAMICS PERFECT HARMONY GH150
 - Excellent versatility for cell-based medium-voltage converters
- SINAMICS PERFECT HARMONY GH180
 - Striking harmony between performance, process and technology.

More information about SINAMICS is available online at www.siemens.com/sinamics

Overview

SINAMICS selection guide – typical applications

Use	Requirements for torque accuracy/speed accuracy/position accuracy/coordination of axes/functionality					
	Continuous motion			Non-continuous motion		
	Basic	Medium	High	Basic	Medium	High
Pumping, ventilating, compressing	Centrifugal pumps Radial / axial fans Compressors	Centrifugal pumps Radial / axial fans Compressors	Eccentric screw pumps	Hydraulic pumps Metering pumps	Hydraulic pumps Metering pumps	Descaling pumps Hydraulic pumps
	V20 G110 G120C G120P	G120P G130/G150 G180 ¹⁾	S120	G120	S110	S120
Moving	Conveyor belts Roller conveyors Chain conveyors	Conveyor belts Roller conveyors Chain conveyors Lifting/lowering devices Elevators Escalators/moving walkways Indoor cranes Marine drives Cable railways	Elevators Container cranes Mining hoists Excavators for open-cast mining Test bays	Acceleration conveyors Storage and retrieval machines	Acceleration conveyors Storage and retrieval machines Cross cutters Reel changers	Storage and retrieval machines Robotics Pick & place Rotary indexing tables Cross cutters Roll feeds Engagers/disengagers
	V20 G110 G110D G110M G120C	G120 G120D G130/G150 G180 ¹⁾	S120 S150 DCM	V90 G120 G120D	S110 DCM	S120 DCM
Processing	Mills Mixers Kneaders Crushers Agitators Centrifuges	Mills Mixers Kneaders Crushers Agitators Centrifuges Extruders Rotary furnaces	Extruders Winders/unwinders Lead/follower drives Calenders Main press drives Printing machines	Tubular bagging machines Single-axis motion control such as • Position profiles • Path profiles	Tubular bagging machines Single-axis motion control such as • Position profiles • Path profiles	Servo presses Rolling mill drives Multi-axis motion control such as • Multi-axis positioning • Cams • Interpolations
	V20 G120C	G120 G130/G150 G180 ¹⁾	S120 S150 DCM	V90 G120	S110	S120 DCM
Machining	Main drives for • Turning • Milling • Drilling	Main drives for • Drilling • Sawing	Main drives for • Turning • Milling • Drilling • Gear cutting • Grinding	Axis drives for • Turning • Milling • Drilling	Axis drives for • Drilling • Sawing	Axis drives for • Turning • Milling • Drilling • Lasering • Gear cutting • Grinding • Nibbling and punching
	S110	S110 S120	S120	S110	S110 S120	S120

Using the SINAMICS selection guide

The varying range of demands on modern variable frequency drives requires a large number of different types. Selecting the optimum drive has become a significantly more complex process. The application matrix shown simplifies this selection process considerably, by suggesting the ideal SINAMICS drive for examples of typical applications and requirements.

- The relevant type of use can be found on the vertical axis (supply, movement, processing or machining).
- What type of movement should be realized with what level of quality (basic, medium, high)? Find this using the relevant fields on the horizontal axis.

To make orientation easier, an example selection of typical applications is shown.

More information

Practical application examples and descriptions are available on the Internet at www.siemens.com/sinamics-applications

¹⁾ Industry-specific inverters.

System Overview

SIMOTICS motors

Overview

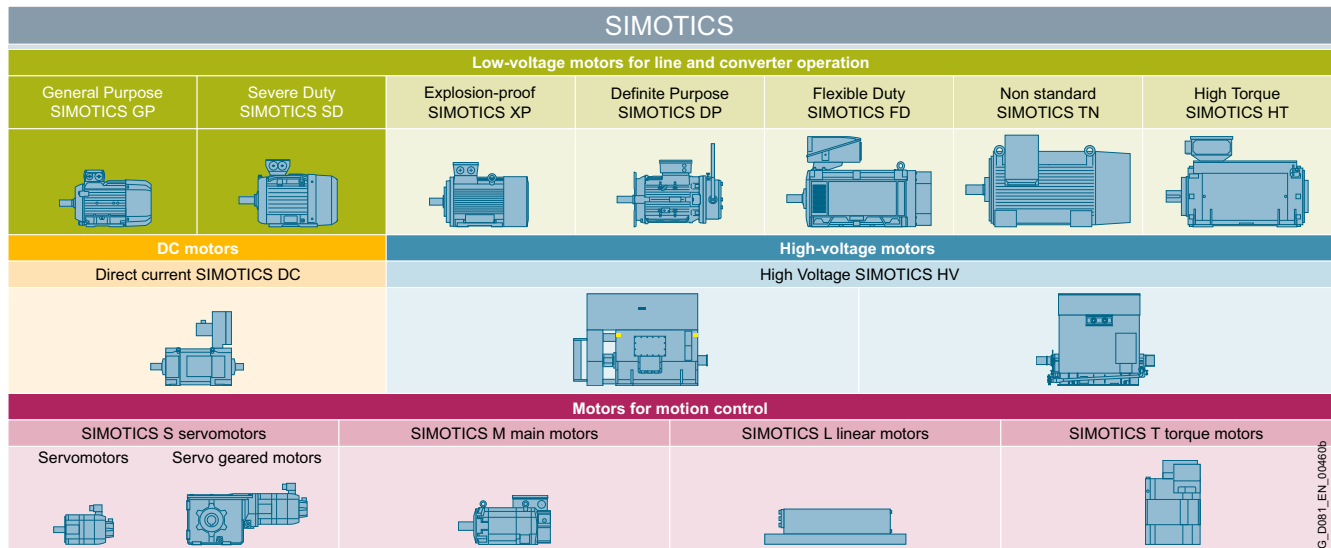

SIMOTICS overview

Further information can be found in Catalogs D 41, D 81.1, D 81.8, D 83.1, D 84.1 and PM 21.

SIMOTICS stands for

- 125 years of experience in building electric motors
- The most comprehensive range of motors worldwide
- Optimum solutions in all industries, regions and power/performance classes
- Innovative motor technologies of the highest quality and reliability
- Highest dynamic performance, precision and efficiency together with the optimum degree of compactness
- Our motors can be integrated into the drive train as part of the overall system
- A global network of skill sets and worldwide service around the clock

A clearly structured portfolio

The entire SIMOTICS product portfolio is transparently organized according to application-specific criteria in order to help users select the optimum motor for their application.

The product range extends from standard motors for pumps, fans and compressors to highly dynamic, precise motion control motors for positioning tasks and motion control in handling applications, as well as production machinery and machine tools, to DC motors and powerful high-voltage motors. Whatever it is that you want to move – we can supply the right motor for the task.

An outstanding performance for any job

A key characteristic of all SIMOTICS motors is their quality. They are robust, reliable, dynamic and precise to assure the requisite performance level for any process and deliver exactly the capabilities demanded by the application in hand. Thanks to their compact design, they can be integrated as space-saving units into installations. Furthermore, their impressive energy efficiency makes them effective as a means of reducing operating costs and protecting the environment.

A dense network of skill sets and servicing expertise around the world

SIMOTICS offers not only a wealth of sound experience gleaned from a development history which stretches back over around 150 years, but also the know-how of hundreds of engineers. This knowledge and our worldwide presence form the basis for a unique proximity to industries which feeds through in tangible terms to the specific motor configuration which is tailored to suit your application.

Our specialists are available to answer all your queries regarding any aspect of motor technology. At any time - wherever you are in the world. When you choose SIMOTICS, therefore, you reap the benefits of a global service network which is continuously accessible, thereby helping to optimize response times and minimize downtimes.

Perfection of the complete drive train

SIMOTICS is perfectly coordinated with other Siemens product families. In combination with the SINAMICS integrated inverter family and the SIRIUS complete portfolio of industrial controls, SIMOTICS fits seamlessly as part of the complete drive train into automation solutions which are based on the SIMATIC, SIMOTION and SINUMERIK control systems.

G_D081_EN_004606

Overview

The flexible, modular drive system for demanding drive tasks

SINAMICS S120 is the modular drive system with vector and servo control that is ideal for sophisticated drive tasks in plant and machine construction.

Multi-axis drive solutions with higher-level motion control can be implemented with the modular SINAMICS S120 system just the same as solutions for single-axis drives.

Covering a power range from 0.12 kW to 5700 kW and various control modules with a graduated range of functions, the modular SINAMICS S120 system can be used to simply and quickly create a precisely tailored drive configuration – for almost any sophisticated drive application.





On the SINAMICS S120, the drive intelligence is combined with closed-loop control functions into Control Units.

These units are capable of controlling drives in the vector, servo and V/f modes. They also perform the speed and torque control functions plus other intelligent drive functions for all axes on the drive.

Using the available closed-loop control techniques, both synchronous as well as induction motors can be operated, and therefore the complete range of low-voltage motors from Siemens.

Integrated PROFIBUS DP interfaces ensure easy integration into complete automation solutions. PROFINET is another of the field-bus interfaces supported by the system.

SINAMICS S120 Cabinet Modules are available as a cabinet system specifically for use in plant construction. These can be combined to form drive cabinet line-ups with a total power rating of up to 5700 kW. Standardized interfaces enable the modules to be linked quickly to create a ready-to-connect drive solution for multi-motor applications.

Drive units for single-axis applications		Drive units for multi-axis applications		
				
Blocksize format	Chassis format	Booksize and booksize compact	Chassis format	Cabinet Modules
Catalog PM 21	This Catalog, Chapter 3	Catalog PM 21	This Catalog, Chapter 3	This Catalog, Chapter 4

Benefits

SINAMICS S120 is characterized by the following properties:

- Can be universally used in high-performance single and multi-axis applications
- Can be freely combined to create customized solutions
- Wide range of power ratings
- Wide range of functions
- SINAMICS Safety Integrated functions
- Supports various cooling types (air/liquid-cooled)
- Supports various infeed concepts
- Can be simply integrated into higher-level automation and IT environments
- User-friendly engineering
- Ease of handling
- Simple installation
- Practical connection system
- Auto-configuration with electronic type plates

System Overview

SINAMICS S120

Application

SINAMICS S120 vector control is recommended for drive solutions with continuous material webs, for example, wire-drawing machines, film and paper machines, as well as for hoisting gear, centrifuges and marine drives with harmonic, circular motion.

SINAMICS S120 with servo control and servo motors is employed for cyclic processes with both precise and highly dynamic closed-loop position control.

With SINAMICS S120, more performance is integrated into machines that are used in many industries, for instance in:

- Packaging machines
- Plastics processing machines
- Textile machines
- Presses and punches
- Printing and paper machines
- Machines used in the woodworking, glass and ceramics industries
- Hoisting gear
- Handling and assembly systems
- Machine tools
- Rolling mill drives
- Vehicle and gearbox test stands
- Test stand applications
- Marine applications

Design

SINAMICS S120 built-in units are available as Power Modules, Line Modules and Motor Modules with the appropriate line-side and motor-side components.

Cooling types

There are various cooling options available depending on the type of construction:

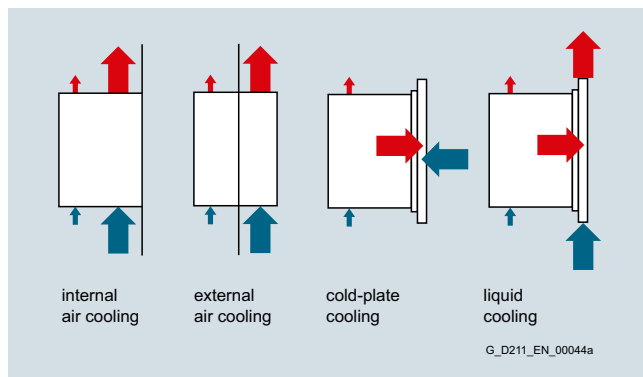

Internal air cooling

In this standard solution, the power loss from the electronics and power units of the drive components is removed by natural cooling or by a forced-ventilation system and routed to the interior of the control cabinet.

External air cooling

External air cooling uses the through-hole technology. The components' power unit heat sinks pass through the mounting surface in the control cabinet and can thus release the heat losses of the power circuit to a separate external cooling circuit. The only heat loss that remains in the cabinet is emitted by the electronics. Degree of protection IP54 can be achieved at this "mechanical interface".

The heat sink, with its cooling fins and the fan unit (part of the scope of supply), protrudes through the back into a separate ventilation area, which can also open outwards.

Cold plate cooling

Devices with cold plate technology are designed such that they dissipate the power loss of the power unit to an external heat sink via a thermal interface on the rear face of the unit. This external heat sink is water-cooled, for example.

Liquid cooling

On liquid-cooled units, the power semiconductors are mounted on a heat sink through which the cooling medium flows. Most of the heat produced by the unit is absorbed by the cooling medium and can be dissipated outside the control cabinet.

Types of construction

Power Modules are available in blocksize and chassis formats. Motor Modules and Line Modules are available in booksize, booksize compact and chassis formats.

Catalog PM 21 provides precise details and ordering data for the booksize, booksize compact and blocksize formats.

Booksize format

Booksize format units are optimized for multi-axis applications and are mounted adjacent to one another. The connection for the common DC link is an integral feature.

The booksize format units are available as internal or external air cooling units.



Booksize compact format

Derived from the booksize format we developed the booksize compact format for machines with particularly high requirements for the compactness of their drives.

The booksize compact format combines all benefits of the booksize format and provides the same performance with an even smaller overall height and an extended overload capability.

The booksize compact format is thus particularly suitable for integration into machines requiring a high dynamic performance and where installation space is restricted.

Design (continued)

The booksize compact format has the same design for the cooling methods of internal air cooling and cold plate cooling.

Blocksize format

Blocksize format units are optimized for single-axis applications and are supplied only as Power Modules. The CU310-2 can be directly snap-mounted. The units are cooled by internal air cooling or liquid cooling.

**Chassis format**

Higher-output units (approximately 100 kW and above) are constructed in chassis format. These drive units are available as:

- Power Modules
- Basic Line Modules
- Smart Line Modules (air-cooled only)
- Active Line Modules
- Active Interface Modules
- Motor Modules

Chassis format units are either cooled by an internal air cooling circuit or liquid-cooled. The CU310-2 Control Unit can be integrated in the Power Modules.



Liquid-cooled units are used primarily for applications where installation space is restricted (up to a 60 % smaller footprint when compared to air cooling) or where low noise emissions are important. They are also suitable for applications in tough ambient conditions.

Cabinet Modules

SINAMICS S120 Cabinet Modules are a modular cabinet system for multi-motor drives with a central supply infeed and a common DC busbar, for example, as used in paper machines, rolling mills, test bays, and hoisting gear. Cabinet Modules are available with a total power rating of up to 4500 kW in the air-cooled version and up to 5700 kW in the liquid-cooled version. The main components of the system are as follows:

- Line Connection Modules
- Basic Line Modules
- Smart Line Modules
- Active Line Modules including Active Interface Modules
- Central Braking Modules
- Motor Modules
- Auxiliary Power Supply Modules



System Overview

1

SINAMICS S150

Overview

The drive solution for demanding single-motor drives



SINAMICS S150 cabinet units are designed for variable-speed drives in plant and machinery construction.

They are especially suitable where high demands are placed on dynamic performance and speed precision, as well as for frequent braking cycles with high braking energies and four-quadrant operation. The drive converter cabinet units provide high performance speed control with a high precision and dynamic performance, and are available for a power range extending from 75 kW up to 1200 kW.

Design

SINAMICS S150 systems are ready-to-connect converters accommodated in a standard control cabinet.

They can be optimally adapted to specific requirements as a result of a wide range of options.

Different variants allow the line and the motor connection to be made at the top or bottom. This ensures a high degree of flexibility regarding how the drive is installed.

The drive units are available with cabinet widths starting from 1400 mm in grid dimension increments of 200 mm. As standard, the cabinets have degree of protection IP20, and can be optionally increased up to IP54. The AOP30 Advanced Operator Panel is fitted as standard in the cabinet door.

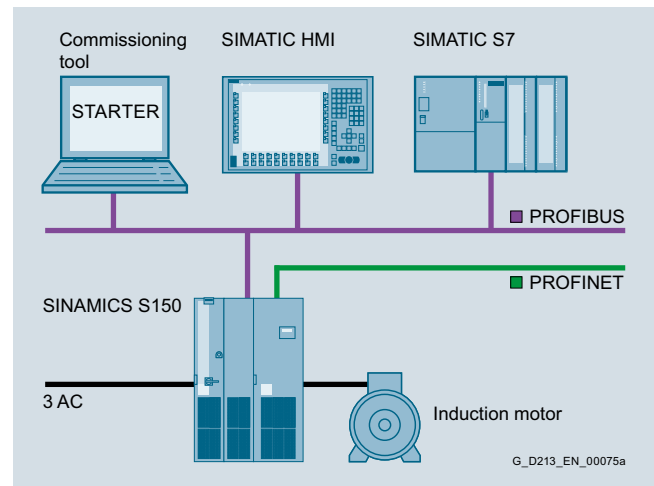

Highlights



2/2 **Safety Integrated**

2/2 Overview

2/3 Function

2/12 **Safety Integrated for SINAMICS S120 Chassis Format Converter Units SINAMICS S120 Cabinet Modules and SINAMICS S150 Drive Converter Cabinet Units**

2/12 Overview

2/13 Benefits

2/14 Function

2/15 **Communication**

2/15 Overview

2/16 PROFIBUS

2/17 Industrial Ethernet

2/18 PROFINET

2/22 PROFIdrive

2/23 USS and Modbus RTU

2/23 CANopen

2/23 EtherNet/IP

Highlights

Safety Integrated

Overview



Legal framework

Machine manufacturers and manufacturing plants must ensure that their machines or plants cannot cause danger due to malfunctions in addition to the general risks of electric shock, heat or radiation.

In Europe, for example, compliance with the machinery directive is legally stipulated by the EU work safety directive. In order to ensure compliance with this directive, it is recommended that the corresponding harmonized European standards are applied. This triggers the "assumption of conformity" and gives manufacturers and operators the legal security in terms of compliance with both national regulations and EU directives. The machine manufacturer uses the CE marking to document the compliance with all relevant directives and regulations in the free movement of goods.

Safety-related standards

Functional safety is specified in various standards. For example, EN ISO 12100 specifies standards pertaining to machine safety (risk assessment and risk reduction). IEC 61508 specifies basic requirements for electronic and programmable safety-related systems. EN 62061 (only applicable for electrical and electronic control systems) and EN ISO 13849-1, which has replaced EN 954-1, define the functional and safety-related requirements of safety-oriented control systems.

The above-mentioned standards define different safety requirements that the machine has to satisfy in accordance with the risk, frequency of a dangerous situation, probability of occurrence and the opportunities for recognizing impending danger.

- EN ISO 13849-1: Performance Level PL a ... e
- EN 62061: Safety Integrity Level SIL 1 ... 3

Trend toward integrated safety systems

The trend toward greater complexity and higher modularity of machines has seen a shift in safety functions away from the classical central safety functions (for example, shutdown of the complete machine using a main disconnecting means) and into the machine control system and the drives. This is often accompanied by a significant increase in productivity because the equipping times are shortened. Depending on the type of machine, it may even be possible to continue manufacturing other parts while equipping is in progress.

Integrated safety functions act much faster than those of a conventional design. The safety of a machine is increased further with Safety Integrated. Furthermore, thanks to the faster method of operation, safety measures controlled by integrated safety systems are perceived as less of a hindrance by the machine operator, therefore significantly reducing the motivation to consciously bypass safety functions.

Function

Safety functions integral to the SINAMICS drives

SINAMICS drives are characterized by a large number of integrated safety functions. In combination with the sensors and safety control required for the safety functionality, they ensure that highly-effective protection for persons and machines is implemented in a practice-oriented manner.

They comply with the following requirements:

- SIL 2 according to IEC 61508
- PL d and Category 3 according to EN ISO 13849-1

Note:

The Safe Brake Test (SBT) diagnostic function meets the requirements for Performance Level (PL) d and Category 2 according to EN ISO 13849-1 and Safety Integrity Level (SIL) 1 according to IEC 61508.

The Safety Integrated functions of SINAMICS drives are certified by independent institutions. You can obtain the corresponding test certificates and manufacturer's declarations from your Siemens contacts.

The integrated safety functions that are currently available in the SINAMICS drive system are described below. The functional safety of all of the functions satisfies the requirements defined in the international standard IEC 61800-5-2 for variable-speed drive systems.

The safety functions integrated into the SINAMICS drive system can be roughly divided into four categories:

- **Functions for safely stopping a drive**
 - Safe Torque Off (STO)
 - Safe Stop 1 (SS1)
 - Safe Stop 2 (SS2)
 - Safe Operating Stop (SOS)
- **Functions for safe brake management**
 - Safe Brake Control (SBC)
 - Safe Brake Test (SBT) (this function exceeds the scope of IEC 61800-5-2)
- **Functions for safely monitoring the motion of a drive**
 - Safely-Limited Speed (SLS)
 - Safe Speed Monitor (SSM)
 - Safe Direction (SDI)
- **Functions for safely monitoring the position of a drive**
 - Safely Limited Position (SLP)
 - Safe Position (SP) (this function exceeds the scope of IEC 61800-5-2)

The Safety Integrated Function Manual contains detailed information about the safety functions.

<https://support.industry.siemens.com/cs/document/99668646>

Further manuals pertaining to Safety Integrated in drive systems can be found on the Internet at

<https://support.industry.siemens.com/cs/ww/en/ps/13231/man>

Further information about Safety Integrated can be found on the Internet at

www.siemens.com/safety-drives

Safe Torque Off (STO)

The STO function is the most common and basic drive-integrated safety function. It ensures that no torque-generating energy can continue to affect a motor and prevents unintentional start-ups.

Activation

This function is a mechanism that prevents the drive from restarting unexpectedly, in accordance with EN 60204-1, Section 5.4. Safe Torque Off suppresses the drive pulses (corresponds to Stop Category 0 of EN 60204-1). The drive is reliably torque-free. This state is monitored internally in the drive.

Application

STO has the immediate effect that the drive cannot supply any torque-generating energy. STO can be used wherever the drive will naturally reach a standstill due to load torque or friction in a sufficiently short time or when "coasting down" of the drive will not have any relevance for safety.

STO makes it possible for persons to work safely when the protective door is open (restart interlock) and is used on machines/installations with moving axes, e.g. on handling or conveyor systems.

Customer benefits

The advantage of the integrated STO safety function compared to standard safety technology using electromechanical switchgear is the elimination of separate components and the effort that would be required to wire and service them. Because of the fast electronic switching times, the function provides a shorter reaction time than the conventional solution comprising electromechanical components.

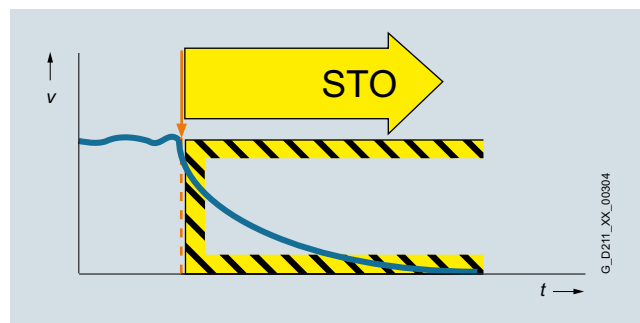

Highlights

Safety Integrated

Function (continued)

Safe Stop 1 (SS1)

The SS1 function causes a motor to stop rapidly and safely and switches the motor to torque-free mode after coming to a standstill, i.e. STO is activated.

Activation

The SS1 function can safely stop the drive in accordance with EN 60204-1, Stop Category 1. When the SS1 function is selected, the drive brakes autonomously along a quick-stop ramp and automatically activates the Safe Torque Off and Safe Brake Control functions (if configured) when the parameterized safety delay time expires.

Application

The SS1 function is used when, in the event of a safety-relevant incident, the drive must stop as quickly as possible with a subsequent transition into the STO state (e.g. EMERGENCY STOP). It is thus used to bring large centrifugal masses to a stop as quickly as possible for the safety of the operating personnel, or to brake motors at high speeds as quickly as possible. Examples of typical applications are saws, grinding machine spindles, centrifuges, winders and storage and retrieval machines.

Customer benefits

The targeted stopping of a drive by means of SS1 reduces the risk of danger, increases the productivity of a machine, and allows the safety clearances in a machine to be reduced. The principle is to bring the drive actively to a standstill, compared with just using the STO function. Complex mechanical brakes that are susceptible to wear are not normally required to brake the motor.

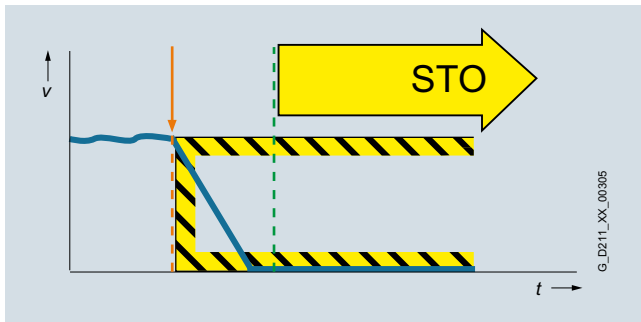

Safe Stop 2 (SS2)

The SS2 function brings the motor to a standstill quickly and safely and then activates the SOS function once the motor has stopped.

Activation

The Safe Stop 2 function can safely stop the drive in accordance with EN 60204-1, Stop Category 2. When the SS2 function is selected, the drive brakes autonomously along a quick stop ramp. In contrast to SS1, the drive control remains operational afterwards, i.e. the motor can supply the full torque required to maintain zero speed. Standstill is safely monitored (Safe Operating Stop function).

Application

As with SS1, the SS2 function ensures the quickest possible deceleration of the motor. However, the motor power is not switched off. Instead, a control system prevents it from leaving the standstill position – even if it is affected by external forces. Typical applications for SS2 include machine tools, for example.

Customer benefits

The SS2 function ensures a rapid axis stop. Because the control remains active, after the safety function is deselected, productive operation can continue without referencing. This ensures short setup and standstill times and high productivity.

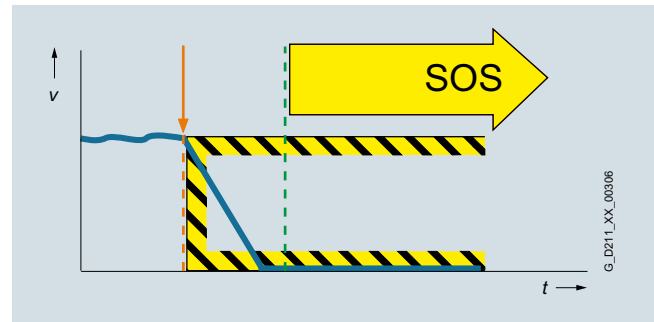

Function (continued)**Safe Operating Stop (SOS)**

With the SOS function, the stopped motor is held in position and monitored by drive control.

Activation

The SOS function constitutes safe standstill monitoring. The drive control remains in operation. The motor can therefore deliver the full torque to hold the current position. The actual position is reliably monitored. In contrast to safety functions SS1 and SS2, the speed setpoint is not influenced autonomously. After SOS has been activated, the higher-level control must bring the drive to a standstill within a parameterized time and then hold the position setpoint.

Application

SOS is an ideal solution for all those applications for which the machine or parts of the machine must be at a safe standstill for certain steps, but the drive must also supply a holding torque. It is ensured that despite counter torque the drive remains in its current position. In contrast to SS1 and SS2, the drive does not brake autonomously in this case. It expects the higher-level controller to ramp down the relevant axes as a coordinated group within an adjustable delay time. This can be used to prevent any damage to the machine or product. Typical applications for SOS include winders, converting and packaging machines and machine tools.

Customer benefits

No mechanical components are necessary to keep the axis in position despite any counterforce that may occur. Due to the short switching times and the fact that the drive control always remains active, setup and downtimes are reduced. Recalibration of the axis after exiting the SOS function is not necessary. The axis can immediately be moved again after deactivation of the SOS function.

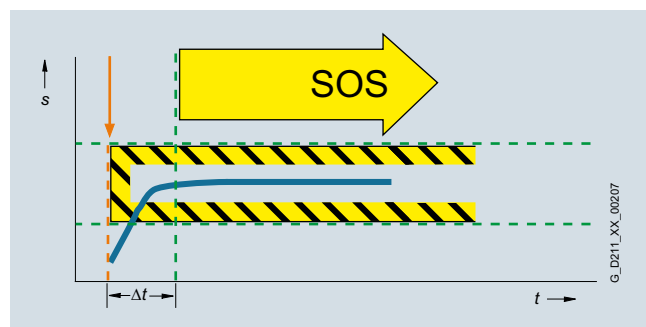
**Safe Brake Control (SBC)**

The SBC function permits the safe control of a holding brake. SBC is always activated in parallel with STO.

Activation

A holding brake which is active in a de-energized state is controlled and monitored using safe two-channel technology. Due to the two-channel control, the brake may still be activated in the event of an insulation fault in the control cable. Errors of this kind are detected early by means of test pulses.

Notes

An additional Safe Brake Relay is required for power units in blocksize format. An additional Safe Brake Adapter is necessary for power units in chassis format.

Application

The SBC function is used in conjunction with the functions STO or SS1 to prevent the movement of an axis in the torque-free state, e.g. because of gravity.

Customer benefits

Again, the function saves the use of external hardware and the associated wiring.

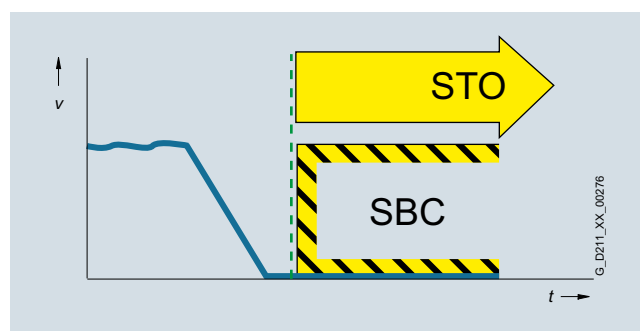

Highlights

Safety Integrated

Function (continued)

Safe Brake Test (SBT)

The SBT diagnostic function carries out a brake function test at regular intervals or before personnel enter the danger zone.

Activation

A good way to check the proper functioning of brakes that have become worn is to apply a torque to the closed brake. Drive systems that have two brakes, e.g. motor brake and external brake, can be tested with different torque values.

Application

The SBT diagnostic function is suitable for implementing a safe brake in combination with the SBC function.

Customer benefits

The function detects faults or wear in the brake mechanics. Automatically testing the effectiveness of brakes reduces maintenance costs and increases the safety and availability of plants/machines.

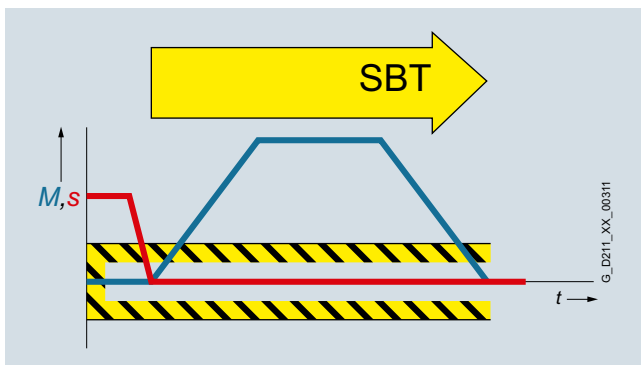

Safely-Limited Speed (SLS)

The SLS function ensures that the drive does not exceed a pre-set speed limit.

Activation

The SLS function monitors the drive against a parameterized speed limit. Four different limit values can be selected. As in the case of SOS, the speed setpoint is not influenced independently. After SLS has been selected, the higher-level control must bring the drive down below the selected speed limit within a parameterizable time. If the speed limit is exceeded, a customizable drive-integrated fault reaction occurs.

The SLS limit stage 1 can be multiplied by a factor that is transferred in 16-bit resolution via PROFIsafe. This allows an almost unlimited number of limits to be specified.

Application

The SLS function is used if people are in the danger zone of a machine and their safety can only be guaranteed by reduced speed. Typical application cases include those in which an operator must enter the danger zone of the machine for the purposes of maintenance or setting up, such as a winder in which the material is manually threaded by the operator. To prevent injury to the operator, the roller may only spin at a safely reduced speed. SLS is often also used as part of a two-stage safety concept. While a person is in a less critical zone, the SLS function is activated, and the drives are only stopped in a smaller area with higher potential risk. SLS can be used not only for operator protection, but also for machinery protection, e.g. if a maximum speed must not be exceeded.

Customer benefits

The SLS function can contribute to a significant reduction in downtime, or greatly simplify or even accelerate setup. The overall effect achieved is a higher availability of the plant. Moreover, external components such as speed monitors can be omitted.

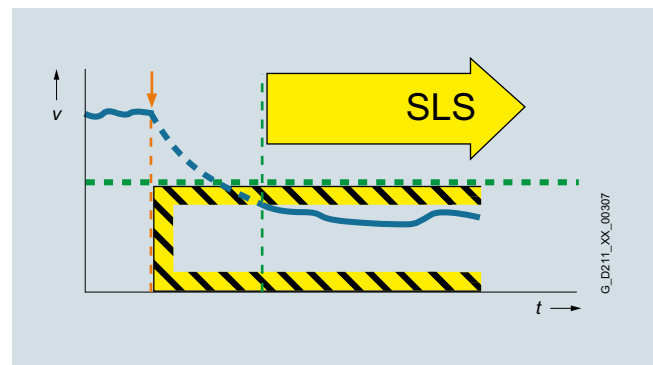

Function (continued)**Safe Speed Monitor (SSM)**

The SSM function warns when a drive is working below an adjustable speed limit. As long as it remains below the threshold, the function issues a safety-related signal.

Activation

If a speed value drops below a parameterized limit, a safety-related signal is generated. This can, for example, be processed in a safety controller to respond to the event by programming, depending on the situation.

Application

With the SSM function, in the simplest case, a safety door can be unlocked if the speed drops below a non-critical level. Another typical example is that of a centrifuge that may be filled only when it is operating below a configured speed limit.

Customer benefits

Unlike SLS, there is no drive-integrated fault reaction when the speed limit is exceeded. The safe feedback can be evaluated in a safety control unit, allowing the user to respond appropriately to the situation.

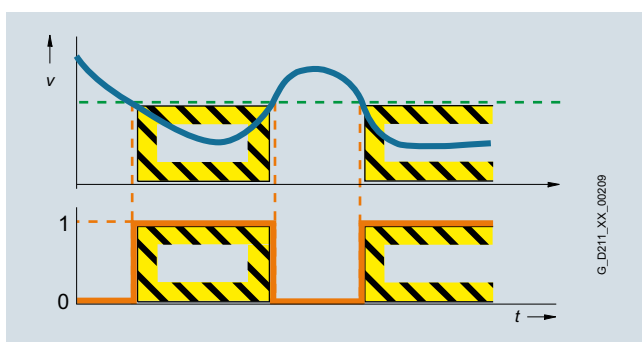
**Safe Direction (SDI)**

The SDI function ensures that the drive can only move in the selected direction.

Activation

Deviation from the direction of motion currently being monitored is detected reliably and the configured drive-integrated fault reaction is initiated. It is possible to select which direction of rotation is to be monitored.

Application

The SDI function is used when the drive may only move in one direction. A typical application is to permit operator access to a danger zone, as long as the machine is rotating in the safe direction, i.e. away from the operator. In this state, the operator can feed material into the work zone / remove material from the work zone without danger.

Customer benefits

The function saves the use of external components such as speed monitors and the associated wiring. The release of a danger zone while the machine is moving away from the operator increases productivity. Without the SDI function, the machine must be safely stopped during material loading and removal.

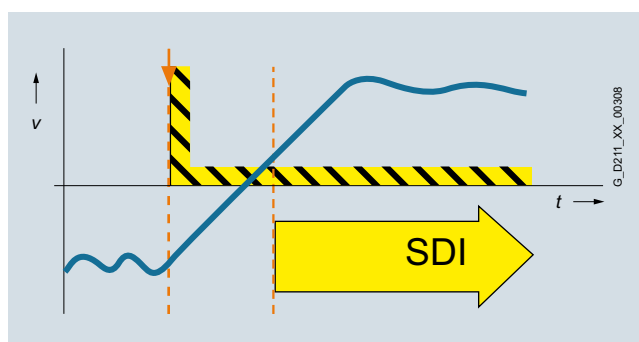

Highlights

Safety Integrated

Function (continued)

Safely Limited Position (SLP)

The SLP function monitors the axis to ensure that it remains within the permissible traversing range.

Activation

When SLP is activated, the traversing range limited by the configured software limit switches is safely monitored. If the permitted traversing range is exited, a customizable fault reaction occurs. It is possible to toggle between two traversing ranges, even when the machine is in operation.

Application

SLP is used for applications in which machine operators have to enter a protection area, e.g. for feeding in and removing material. Safe monitoring of the axis position ensures that the axis cannot move into the protection area released for operators and so place them in danger, for example, on storage and retrieval machines, gantry cranes or machining centers.

Customer benefits

SLP can be used for highly-effective protection area monitoring. The function does away with the use of external components such as hardware limit switches and the associated wiring expense. Due to the short reaction time following a limit overshoot, safety clearances can be reduced.

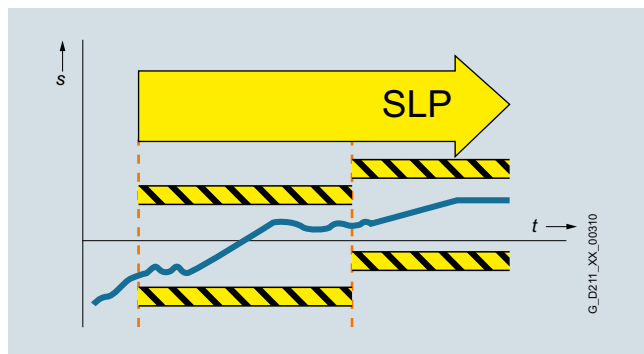

Safe Position (SP)

The SP function transfers the actual position values determined safely in the drive over safe PROFIsafe communication to a safety control.

Activation

In contrast to the SLP function that monitors the current actual position value against a limit and, in the case of an overshoot, activates a drive-integrated fault reaction, SP transfers the current actual position values to the safety control. Position monitoring is implemented in the safety program of the control. Extended PROFIsafe telegrams are available for transferring the position values. The position values can be transferred in 16-bit or 32-bit resolution, as required. A time stamp is also transferred with the position values.

Application

Tailor-made safety concepts can be created using the SP function. It is ideal for use on machines that require flexible safety functions. It is extremely versatile and can be used, for example, to implement safe, axis-specific range detection by means of safe cams. The SP function can also be used to implement multi-axis safety concepts, multi-dimensional protection areas and zone concepts.

Customer benefits

Position monitoring or speed monitoring is implemented in the safety program of the control, so the user has the flexibility for implementing tailor-made safety functions. The reaction to a limit overshoot must also be specified in the safety program. This means a higher initial programming outlay, but it does offer the opportunity for initiating different fault reactions.

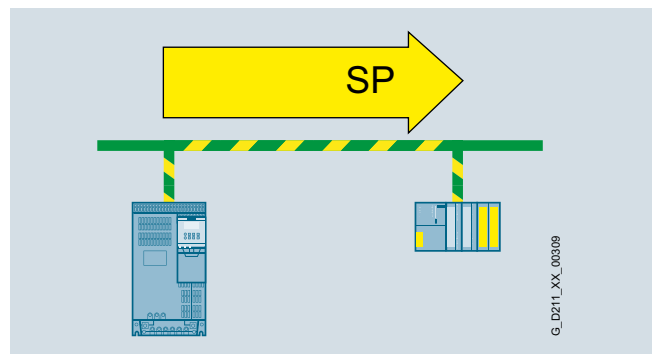

Function (continued)**Basic Functions and Extended Functions**

The Safety Integrated functions of the SINAMICS drive system are grouped into Basic Functions and Extended Functions.

- Basic Functions
 - Safe Torque Off (STO)
 - Safe Brake Control (SBC)
 - Safe Stop 1 (SS1)
- Extended Functions
 - Safe Stop 1 (SS1) with SBR or SAM
 - Safe Stop 2 (SS2) with SAM
 - Safe Operating Stop (SOS)
 - Safely Limited Speed (SLS) with SAM
 - Safe Speed Monitor (SSM)
 - Safe Direction (SDI)
 - Safely Limited Position (SLP)
 - Safe Position (SP)
 - Safe Brake Test (SBT) diagnostic function
 - Safe Acceleration Monitor (SAM) diagnostic function
 - Safe Brake Ramp (SBR) diagnostic function

For the Extended Functions Safe Stop 1 (SS1), Safe Stop 2 (SS2) and Safely Limited Speed (SLS) with SAM, safe acceleration monitoring (SAM) is performed during braking to identify any faults already during the braking phase.

If Safe Stop 1 is used as an encoderless function, a Safe Brake Ramp (SBR) can be configured as an alternative.

The Basic Functions – activated via on-board terminals on the device or via PROFIsafe – do not require an encoder.

Activation of the integrated safety functions

The safety functions for SINAMICS drives can be activated via terminals, e.g. for use of a conventional safety circuit.

For standalone safety solutions for small to medium sized applications, it is frequently sufficient that the various sensing components are directly hardwired to the drive.

For integrated safety solutions, the safety-relevant sequences are generally processed and coordinated in the fail-safe SIMATIC controller. Here, the system components communicate via the PROFINET or PROFIBUS fieldbus. The safety functions are controlled via the safe PROFIsafe communication protocol.

SINAMICS drives can be easily integrated into the plant or system topology.

PROFIsafe

SINAMICS drives support the PROFIsafe profile based on PROFIBUS as well as on PROFINET.

PROFIsafe is an open communications standard that supports standard and safety-related communication over the same communication path (wired or wireless). A second, separate bus system is therefore not necessary. The telegrams that are sent are continually monitored to ensure safety-relevant communication.

Possible errors such as telegrams that have been lost, repeated or received in the incorrect sequence are avoided. This is done by consecutively numbering the telegrams in a safety-relevant fashion, monitoring their reception within a defined time and transferring an ID for transmitter and receiver of a telegram. A CRC (cyclic redundancy check) data security mechanism is also used.

The operating principle of Safety Integrated**Two independent switch-off signal paths**

Two independent switch-off signal paths are available. All switch-off signal paths are low active. This ensures that the system is always switched to a safe state if a component fails or in the event of cable breakage. If an error is discovered in the switch-off signal paths, the Safe Torque Off or Safe Stop 1 function is activated (depending on the parameterization) and a system restart inhibited.

Two-channel monitoring structure

All the main hardware and software functions for Safety Integrated are implemented in two independent monitoring channels (e.g. switch-off signal paths, data management, data comparison). A cyclic crosswise comparison of the safety-relevant data in the two monitoring channels is carried out.

The monitoring functions in each monitoring channel work on the principle that a defined state must prevail before each action is carried out and a specific acknowledgement must be made after each action. If these expectations of a monitoring channel are not fulfilled, the drive coasts to a standstill (two channel) and an appropriate message is output.

Forced dormant error detection using test stop

The functions and switch-off signal paths must be tested at least once within a defined time in order to meet requirements as per EN ISO 13849-1 and IEC 61508 in terms of timely fault detection. This must be implemented either in cyclic manual mode or the test stop must be automatically initiated as part of the process. The test stop cycle is monitored, and after a specific time has been exceeded, an alarm is output. A test stop does not require a POWER ON. The acknowledgment is set by canceling the test stop request.

Examples of when forced dormant error detection must be performed:

- When the drives are at a standstill after the system has been switched on
- Before the protective door is opened
- At defined intervals (e.g. every 8 hours)
- In automatic mode, time and event-driven

Highlights

Safety Integrated

Function (continued)

Safe actual value sensing with or without encoders

A drive monitor with encoder is necessary for operation of a series of safety functions.

For applications with encoderless mode or with encoders that have no safety capability, the safety functions can also be implemented without encoder. It is not possible to use all safety functions in this case.

The encoderless safety functions can be implemented on request for chassis format units (see the Function Manuals SINAMICS S120 Safety Integrated and SINAMICS G130, G150, S120 Chassis, S120 Cabinet Modules, S150; Safety Integrated).

In operation without encoder, the actual speed values are calculated from the measured electrical actual values. Therefore, speed monitoring is also possible during operation without encoder.

An encoder that is used for the purposes of motor control has no significance for the safety function here.

Safety Integrated Extended Functions "without encoder" must not be used if the motor, after it has been switched off, can still be accelerated by the mechanical elements of the connected machine component.

In the hoisting gear of a crane, for example, the suspended load can accelerate the motor as soon as the motor is switched off. In this case, the safety functions "without encoder" are not permitted.

A horizontal conveyor, on the other hand, is always braked to a standstill due to friction as soon as the motor is switched off. In this case, the safety functions "without encoder" can be used without any restriction.

Additional information on the encoderless safety functions is available in the Safety Integrated Function Manuals at www.siemens.com/sios (search terms 99668646 and 106254588).

The safety functions are listed below with criteria for actual value sensing:

	Functions	Abbreviation	With encoder	Without encoder	Description
Basic Functions	Safe Torque Off	STO	Yes	Yes	Safe Torque Off
	Safe Stop 1	SS1	Yes	Yes	Safe Stop according to stop category 1
	Safe Brake Control	SBC	Yes	Yes	Safe Brake Control
Extended Functions	Safe Torque Off	STO	Yes	Yes ¹⁾	Safe Torque Off
	Safe Stop 1	SS1	Yes	Yes ¹⁾	Safe Stop according to stop category 1
	Safe Brake Control	SBC	Yes	Yes ¹⁾	Safe Brake Control
	Safe Operating Stop	SOS	Yes	No	Safe monitoring of the standstill position
	Safe Stop 2	SS2	Yes	No	Safe Stop according to stop category 2
	Safely Limited Speed	SLS	Yes	Yes ¹⁾	Safe monitoring of the maximum speed
	Safe Speed Monitor	SSM	Yes	Yes ¹⁾	Safe monitoring of the minimum speed
	Safe Direction	SDI	Yes	Yes ¹⁾	Safe monitoring of the direction of motion
	Safely Limited Position	SLP	Yes	No	Safely-limited position
	Safe Position	SP	Yes	Yes	Safe transfer of position values
	Safe Brake Test	SBT	Yes	No	Diagnostic function for safe testing of the required holding torque of a brake
	Safe Acceleration Monitor	SAM			
	Safe Brake Ramp	SBR			

¹⁾ The use of this safety function without encoder is permitted only on request and only for induction motors or synchronous motors of the SIEMOSYN series.

Function (continued)**Safe speed/position sensing with encoder**

Incremental encoders or absolute encoders with photoelectric sampling are permitted for safe sensing of the position values on a drive. HTL/TTL incremental encoders may also be used.

Safe actual value sensing relies on redundant evaluation of the incremental tracks A/B that supply sin/cos signals of $1 V_{pp}$. Only encoders of the type whose A/B track signals are created and processed using purely analog techniques can be used. The encoder signals are input via the SMC20 Sensor Module Cabinet-Mounted (option **K48** for cabinets).

For HTL/TTL incremental encoders, safe actual value sensing is achieved by using two independent encoders. The minimum possible speed resolution must also be taken into account. The encoder signals are input via the SMC30 Sensor Module Cabinet-Mounted (options **K50** and **K52** for cabinets).

When motors with a DRIVE-CliQ interface are used, the actual speed/position values are generated directly in the motor as safe values and transferred to the Control Unit via a safe DRIVE-CliQ communication link.

The following can be used for safe speed/position sensing:

- Single-encoder systems or
- 2-encoder systems

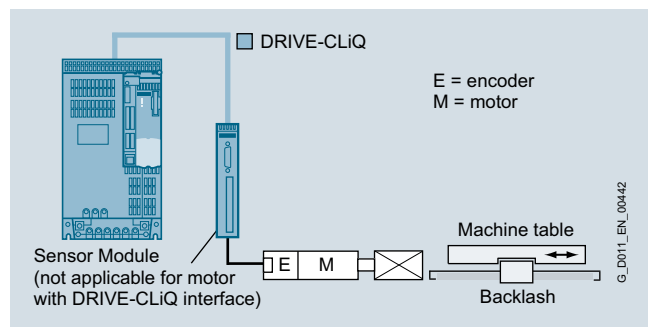

Example: Single-encoder system

In a single-encoder system, the motor encoder is used exclusively for safe actual value sensing. An incremental encoder or absolute encoder with photoelectric sampling must be used in this case.

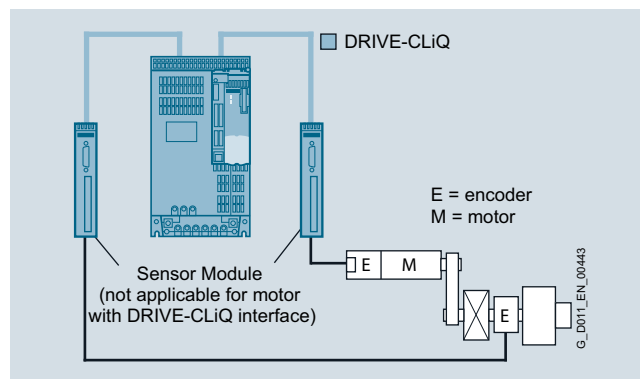

Example: Dual-encoder system

In the case of the 2-encoder system, the safe actual values for a drive are provided by two separate encoders. For this configuration, either two HTL/TTL encoders, one dual-HTL/TTL encoder or one HTL/TTL encoder and one sin/cos encoder can be used. The mechanical installation of the encoder must be performed in such a way as to exclude the possibility of the encoder shaft loosening or slipping through.

For notes on this please refer to IEC 61800-5-2:2007, Table D. 16. The actual values are transferred to the Control Unit via DRIVE-CliQ. When motors without a DRIVE-CliQ connection are used, a Sensor Module (SMC20/30, SME20/25/120/125) must be provided. Each measuring system requires a separate DRIVE-CliQ connection.

Highlights

Safety Integrated for SINAMICS S120 Chassis Format Converter Units and Cabinet Modules, and for SINAMICS S150

Overview

The safety functions integrated into the drive can greatly reduce the effort required to implement safety concepts.

The Safety Integrated functions are implemented electronically and therefore offer short response times compared with solutions with externally implemented monitoring functions.

As an alternative to controlling via terminals and/or PROFIsafe, there is also the option to parameterize some safety functions without selection. In this mode, after parameterization and a POWER ON, these functions are permanently selected.

Example

"SLS without selection" can be used, for example, to monitor the maximum velocity to prevent the drive from exceeding a mechanical speed limit. For this purpose, use of the "SLS without selection" function means that an F-DI is not needed.

Safety Integrated with and without encoder

The Safety Integrated Basic Functions STO, SBC, and SS1 can be operated without an encoder. To use Safety Integrated Extended Functions SLS, SDI, SOS, SS2, and SSM, two safety-capable incremental encoders (HTL or TTL) are required. These are each connected to a Sensor Module Cabinet SMC30 (with SINAMICS S120 Cabinet Modules and SINAMICS S150: first SMC30 option **K50**, second SMC30 option **K52**). The minimum possible velocity resolution for an HTL/TTL encoder system must be taken into account.

Further information can be found in the [Safety Integrated Function Manual](#).

Licensing

The Safety Integrated Basic Functions do not require a license.

The Safety Integrated Extended Functions require one license for each axis with safety functions. It is of no consequence here which safety functions are used and how many.

The licenses for SINAMICS S120 devices can be ordered as option **F01 to F05** at the same time as the memory card. For SINAMICS S120 Cabinet Modules, the licenses can be ordered for specific axes with safety options **K01 to K05** for Motor Modules.

The license for SINAMICS S150 devices can be ordered as option **K01**.

Safe Brake Adapter

The Safe Brake Control (SBC) function requires a Safe Brake Adapter (option **K88** for SINAMICS S120 Cabinet Modules and SINAMICS S150). Safe Brake Control is integrated in Motor Modules in booksize format.

The Safe Brake Adapter and the brake control that is integrated in the booksize format allow safe control of electro-mechanical motor brakes.

The Safe Brake Adapter controls 230 V AC brakes. The SBC function monitors the control of the brake, however, not its mechanical functioning.

The converter controls the connected brake using the motor holding brake function.

External surge suppressors are not required. The cable harnesses for connection to the Power Module are included in the scope of supply.

The brake is controlled in accordance with IEC 61508 SIL 2 and EN ISO 13849-1 PL d and Category 3.

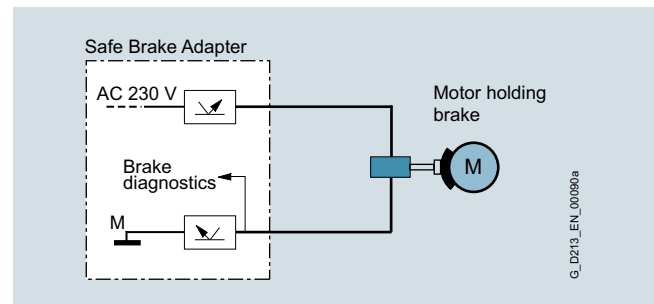

Safe Brake Control (SBC)

Safety Integrated for SINAMICS S120 Chassis Format Converter Units and Cabinet Modules, and for SINAMICS S150

Benefits

Comparison between conventional and integrated safety systems

The Safety Integrated functions are fully integrated in the drive system. They can be activated as follows:

- Via safety-related inputs on the CU310-2 Control Unit or on the power units (Basic Functions)
- Via safety-related inputs on the TM54F Terminal Module (Extended Functions)
- Via PROFIBUS or PROFINET with the PROFIsafe profile (Basic and Extended Functions)

Safe Torque Off (STO)

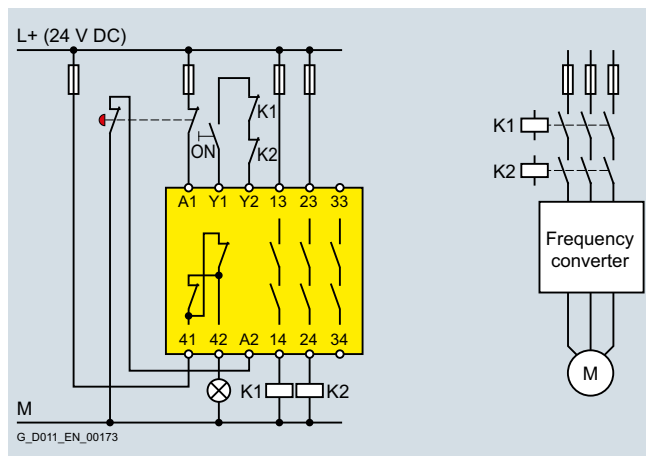

Conventional wiring

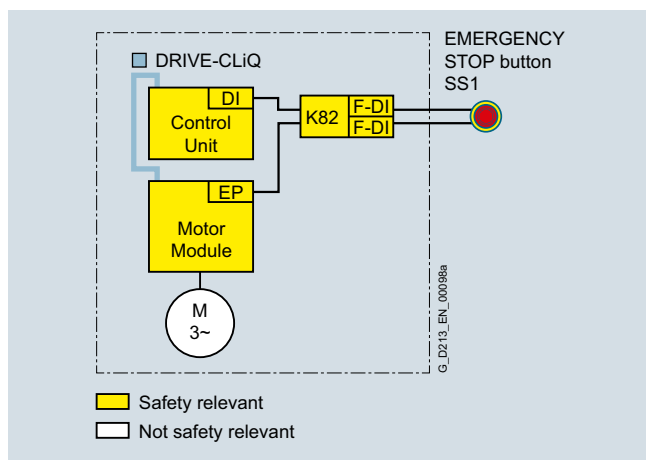

Integrated safety via fail-safe inputs

Safely-Limited Speed (SLS)

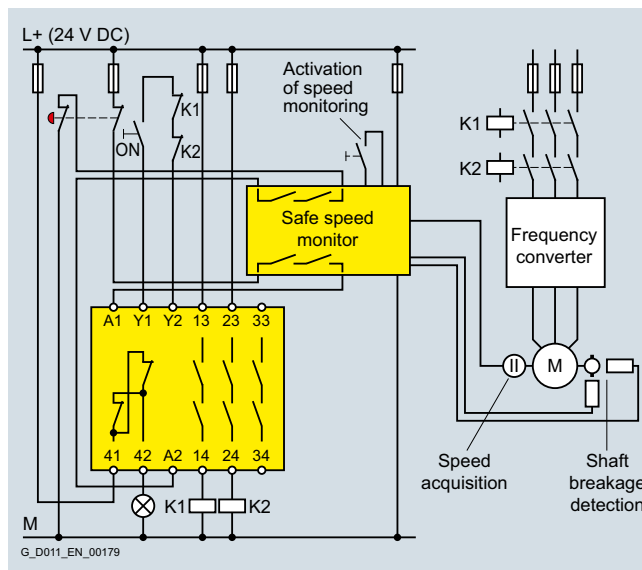

Conventional wiring

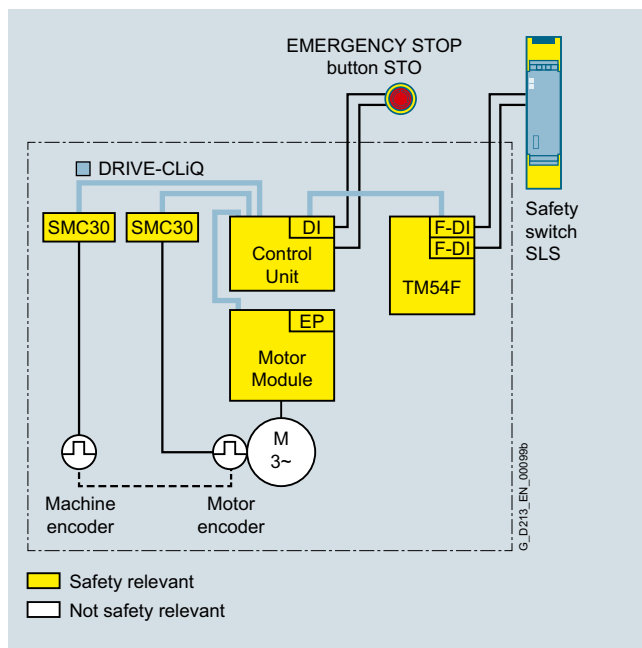

Integrated safety via fail-safe inputs

The TM54F Terminal Module is not required when functions are selected via PROFIsafe.

Highlights

Safety Integrated for SINAMICS S120 Chassis Format Converter Units and Cabinet Modules, and for SINAMICS S150

Function

Overview of Safety Integrated functions

Function	Control	Underlying function	Reaction to limit overshoot	External setpoint input effective	Encoder required ¹⁾	License required
Basic Functions						
STO	<ul style="list-style-type: none"> EP terminals on the power units and F-DI on CU310-2/D4xx/CX32 Terminal module (option K82 ²⁾) PROFIsafe 	SBC (if activated)	–	No	No ³⁾	No ⁴⁾
SBC	<ul style="list-style-type: none"> With STO (immediately or following expiration of the delay time with SS1) Via Safe Brake Adapter ²⁾ 	–	–	–	No	No
SS1	<ul style="list-style-type: none"> EP terminals on the power units and F-DI on CU310-2/D4xx/CX32 Terminal module (option K82 ²⁾) PROFIsafe 	STO following expiry of the parameterized delay time, SBC (if activated)	STO	Parameterizable	No	No
Extended Functions						
STO	<ul style="list-style-type: none"> F-DI on TM54F PROFIsafe 	SBC (if activated)	–	No	Yes ³⁾	Yes ⁴⁾
SS1 with SBR/SAM	<ul style="list-style-type: none"> F-DI on TM54F F-DI on CU310-2/D4xx/CX32 PROFIsafe 	Safe Acceleration Monitor (SAM) or Safe Brake Ramp (SBR) during braking. STO and SBC (if activated) following expiry of the parameterized delay time or if the speed falls below the minimum speed limit	STO	Parameterizable	No	Yes
SS2	<ul style="list-style-type: none"> F-DI on TM54F F-DI on CU310-2/D4xx/CX32 PROFIsafe 	Safe Acceleration Monitor (SAM) during braking. Following expiry of the parameterized delay time SOS	SS1 → STO	No	Yes	Yes
SLS encoderless	<ul style="list-style-type: none"> F-DI on TM54F F-DI on CU310-2/D4xx/CX32 PROFIsafe Continuously activated 	–	STO, SS1 (can be parameterized)	Yes	No	Yes
SLS	<ul style="list-style-type: none"> F-DI on TM54F F-DI on CU310-2/D4xx/CX32 PROFIsafe Continuously activated 	–	STO, SS1, SS2, or SOS (can be parameterized)	Yes	Yes	Yes
SOS	<ul style="list-style-type: none"> F-DI on TM54F F-DI on CU310-2/D4xx/CX32 PROFIsafe 	–	SS1 → STO	Yes	Yes	Yes
SSM	<ul style="list-style-type: none"> Always active, if configured 	–	Signals that the speed has fallen below a specified value	Yes	No	Yes
SDI	<ul style="list-style-type: none"> F-DI on TM54F F-DI on CU310-2/D4xx/CX32 PROFIsafe Continuously activated 	–	STO, SS1, SS2, or SOS (can be parameterized)	Yes	No	Yes
SLP	<ul style="list-style-type: none"> F-DI on TM54F F-DI on CU310-2/D4xx/CX32 PROFIsafe 	–	STO, SS1, SS2, or SOS (can be parameterized)	Yes	Yes	Yes
SP	<ul style="list-style-type: none"> Always active, if configured 	–	–	Yes	Yes	Yes
SBT	<ul style="list-style-type: none"> F-DI on TM54F F-DI on CU310-2/D4xx/CX32 PROFIsafe 	–	Signals test result. Warning if test fails	Yes	Yes	Yes

¹⁾ The encoderless Safety Extended Functions can only be implemented on request for SINAMICS S120 chassis format units and cabinet units.

²⁾ In addition for SINAMICS S120 Cabinet Modules and SINAMICS S150 converter cabinet units (**K88** option).

³⁾ Activation using terminals on the TM54F requires an encoder.

⁴⁾ Activation using terminals on the TM54F requires a license.

Overview

Communication overview

Digital bus systems are commonly used in industrial automation today. These handle communication between the control level, the machine control, the sensors and actuators. The SINAMICS product family offers integrated communication interfaces in all product groups – which can be used to connect the most important fieldbus systems in the simplest possible way.

The properties and special application areas of the different bus systems are described briefly below. The following table provides an overview of the protocols available for the CU310-2 and CU320-2 Control Units.

Protocol	CU310-2	CU320-2
PROFINET	✓	✓
• PROFINET RT	✓	✓
• PROFINET IRT isochronous	✓	✓
• PROFINET IRT not isochronous	✓	✓
• PROFINET Shared Device	✓	✓
• PROFINET media redundancy MRP (surge prone)	✓	✓
• PROFINET media redundancy MRPD (surge free)	✓	✓
• PROFIsafe	✓	✓
• PROFIenergy	✓	✓
• PROFIdrive application class 1	✓	✓
• PROFIdrive application class 3	✓	✓
• PROFIdrive application class 4	✓	✓
PROFIBUS DP	✓	✓
• PROFIBUS DP equidistance and isochronous mode	✓	✓
• PROFIBUS DP peer-to-peer communication	✓	✓
USS	✓	✓
EtherNet/IP	–	✓
CANopen	–	✓
Web server	✓	✓

Highlights

Communication > PROFIBUS

Overview



PROFIBUS – the most successful open fieldbus in the automation environment

The requirements of users for an open, non-proprietary communication system have resulted in the specification and standardization of the PROFIBUS protocol.

PROFIBUS defines the technical and functional features of a serial fieldbus system, with which the distributed field automation devices in the lower area (sensor/actuator level) can be networked up to the mid performance range (cell level).

Standardization according to IEC 61158/EN 50170 secures your investments for the future.

Using the conformity and interoperability test performed by the test laboratories authorized by PROFIBUS & PROFINET International (PI) and the certification of the devices by PI, users have the security of knowing that the quality and functionality is guaranteed, even in multi-vendor installations.

PROFIBUS versions

Three different PROFIBUS versions have been defined in order to comply with the widely differing requirements at the field level:

PROFIBUS FMS (Fieldbus Message Specification) – the universal solution for communication tasks at the field and cell levels in the industrial communication hierarchy.

PROFIBUS PA (Process Automation) – the version for applications in process automation. PROFIBUS PA uses the intrinsically safe transmission technology specified in IEC 61158-2.

PROFIBUS DP (Distributed Periphery) – this version, which is optimized for speed, is specifically tailored to the communication of automation systems with distributed I/O stations and drives. PROFIBUS DP sets itself apart as a result of very short response times and high noise immunity, and replaces cost-intensive, parallel signal transfer with 24 V and measured value transfer utilizing 0/4 ... 20 mA technology.

Design

Bus participants on PROFIBUS DP

PROFIBUS DP makes a distinction between two different master classes and one slave class:

DP master class 1

For PROFIBUS DP, DP master class 1 is the central component. In a defined and continually repeating message cycle the central master station exchanges information with distributed stations (DP slaves).

DP master class 2

Devices of this type (programming, configuring or operator control devices) are used during commissioning, for configuring the DP system, for diagnostics or for operating the active plant or system. A DP master class 2 can, for example, read input, output, diagnostic and configuration data of the slaves.

DP slave

A DP slave is an I/O device which receives output information or setpoints from the DP master, and as response, returns input information, measured values and actual values to the DP master. A DP slave never sends data automatically, but only when requested by the DP master.

The quantity of input and output information depends on the device, and for each DP slave in each send direction can be a maximum of 244 bytes.

Function

Functional scope in DP masters and DP slaves

The functional scope can differ between DP masters and DP slaves. The different functional scopes are classified as DP-V0, DP-V1 and DP-V2.

DP-V0 communication functions

The DP-V0 master functions consist of "Configuration", "Parameter Assignment" and "Reading Diagnostics Data", as well as cyclic reading of input data/actual values and writing output data/setpoints.

DP-V1 communication functions

The DP-V1 function expansions make it possible to perform acyclic read and write functions as well as processing cyclic data communication. This type of slave must be supplied with extensive parameterization data during start-up and during normal operation. These acyclically transferred parameterization data are only rarely changed in comparison to the cyclic setpoints, actual values, and measured values, and are transferred at lower priority in parallel with the cyclic high-speed user data transfer. Detailed diagnostic information can be transferred in the same way.

DP-V2 communication functions

The extended DP-V2 master functions mainly comprise functions for isochronous operation and direct data exchange between DP slaves.

- **Isochronous mode:**
Isochronous mode is implemented by means of an equidistant signal in the bus system. This cyclic, equidistant clock signal is sent by the DP master to all bus nodes in the form of a global control frame. Master and slaves can then synchronize their applications with this signal. The signal jitter between cycles is less than 1 μ s.
- **Slave-to-slave:**
The "publisher/subscriber" model is used to implement slave-to-slave communication. Slaves declared as publishers make their input data/actual values and measured values available to other slaves, the subscribers, for reading. This is done by sending the response frame to the master as a broadcast. Slave-to-slave communication is therefore a cyclic process.

PROFIBUS with SINAMICS

SINAMICS uses the PROFIBUS DP protocol.

The SINAMICS drives can only be used as DP slaves.

Overview

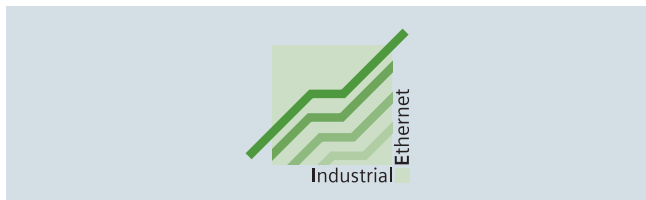

Ethernet is the basic Internet technology for worldwide networking. The wide variety of options of Intranet and Internet, that have long been available in the office environment, are now being made available to factory automation with Industrial Ethernet.

Apart from the use of information technology, the deployment of distributed automation systems is also on the increase. This means the breakdown of complex control tasks into smaller, manageable and drive-based control systems. This in turn is boosting the demand for communication which necessitates an extensive and powerful communication system.

Industrial Ethernet provides a powerful area and cell network for the industrial field, compliant with the IEEE 802.3 (ETHERNET) standard.

Benefits

Ethernet enables a very fast data transfer (10/100 Mbit/s, 1/10 Gbit/s) and at the same time has full-duplex capability. It therefore provides an ideal basis for communication tasks in the industrial field. With a share of over 90%, Ethernet is the number one network worldwide and offers important features which have essential advantages:

- Fast commissioning thanks to extremely simple connection method
- High availability since existing networks can be extended without any adverse effects
- Almost unlimited communication performance because scalable performance is available through switching technology and high data rates when required
- Networking of different application areas such as office and production areas
- Company-wide communication based on wide area network (WAN) technology or the Internet
- Protection of investment due to continuous and compatible development
- Wireless communication using industrial wireless LAN

In order to make Ethernet suitable for industrial applications, considerable expansions with respect to functionality and design are required:

- Network components for use in harsh industrial environments
- Fast assembly of the RJ45 connectors
- Fail-safety through redundancy
- Expanded diagnostics and message concept
- Use of future-oriented network components (e.g. switches)

SIMATIC NET offers corresponding network components and products.

Design

Industrial Ethernet with SINAMICS S

SINAMICS S provides Control Units and Communication Boards with PROFINET interface based on 100 Mbit/s Ethernet. This means that process communication in real-time, as well as engineering and HMI via standard TCP/IP are simultaneously possible.

The CU310-2 und CU320-2 Control Units have an additional Ethernet interface at the front so that service and engineering tasks can be performed very easily.

Communication with SINAMICS S over Industrial Ethernet

PG/OP/PC communication

PG/OP/PC communication is performed using protocols which are based on the basic TCP/IP protocol.

- Engineering and diagnostics with STARTER

IT communication

IT communication is performed using protocols which are based on the basic TCP/IP protocol. The most important IT protocols are:

- HTTP/HTTPS: Hypertext Transfer Protocol
Using a standard Internet browser, it is possible to retrieve predefined Web pages containing diagnostic information from the device. Furthermore, user-defined web pages containing information defined by the user can be stored in the device
- SNMP: Simple Network Management Protocol

Highlights

Communication > PROFINET

Overview



PROFINET – the Ethernet standard for automation

PROFINET is the world's leading Industrial Ethernet standard for automation with more than three million nodes installed worldwide.

PROFINET makes companies more successful, because it speeds up processes and raises both productivity and plant availability.

Your advantages at a glance

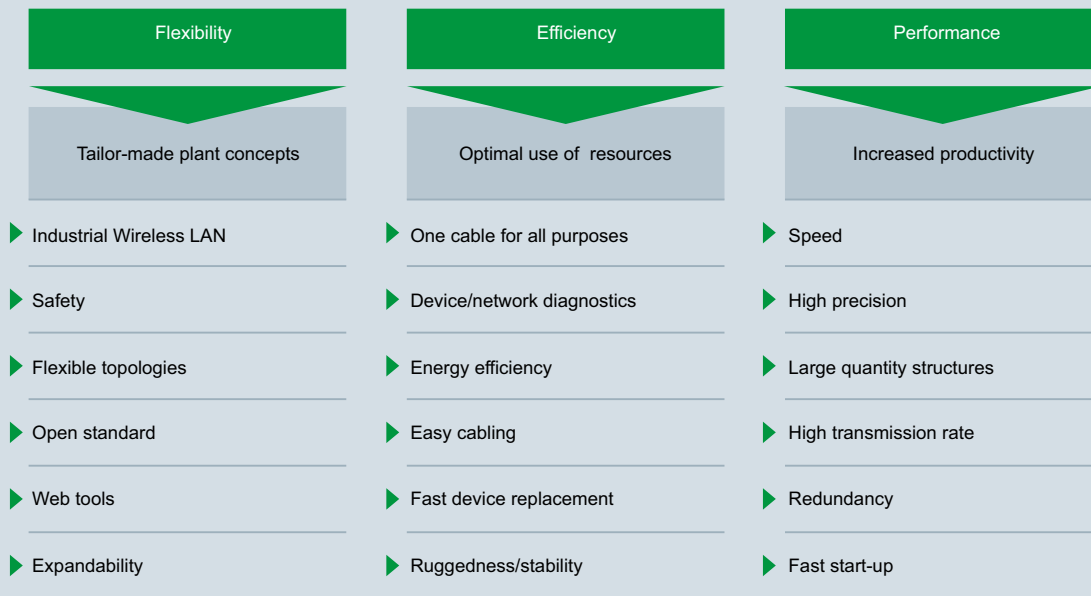

G_IK10_XX_10304

Flexibility

Short response times and optimized processes are the basic requirements for competitiveness in global markets because the product lifecycles are increasingly becoming shorter.

PROFINET ensures maximum flexibility in plant structures and production processes and enables innovative machine and plant concepts to be implemented. For example, mobile devices can also be integrated at locations that are difficult to access.

Flexible topologies

In addition to the linear structure characterized by the established fieldbuses, PROFINET also enables the use of star, tree and ring structures. This is made possible by the switching technology via active network components, such as Industrial Ethernet switches and media converters, or by integrating switch functionality into the field devices. This creates greater flexibility for the planning of machines and plants, as well as reducing the cabling requirements.

The PROFINET network can be installed without any specialist knowledge at all and meets all requirements that are relevant in the industrial environment. The PROFINET Guideline "Cabling and Interconnection Technology" supports manufacturers and users during network installation. Symmetrical copper cables or RFI-resistant fiber-optic cables are used, depending on the application. Devices from different manufacturers are easily connected via standardized and rugged plug connectors (up to IP65/IP67 degree of protection).

By integrating switch functionality into the devices, linear structures can be created that are directly oriented toward an existing machine or plant structure. This reduces cabling overhead and cuts down on components such as external switches.

IWLAN

PROFINET also supports wireless communication with Industrial Wireless LAN, opening up new fields of application. For example, technologies subject to wear, such as trailing cables, can be replaced and the use of automated guided vehicle systems and mobile operator terminals becomes possible.

Safety

The PROFIsafe safety profile, which has been tried and tested with PROFIBUS and which permits the transmission of standard and safety-related data on a single bus cable, can also be used with PROFINET. No special network components are necessary for fail-safe communication, which means that standard switches and standard network transitions can continue to be used without any restrictions. In addition, fail-safe communication is equally possible via Industrial Wireless LAN (IWLAN).

Open standard

PROFINET, the open multi-vendor standard (IEC 61158/IEC 61784), is supported by PROFIBUS and PROFINET International (PI). It stands for maximum transparency, open IT communication, network security and simultaneous real-time communication.

Overview (continued)

Thanks to its openness, PROFINET provides the basis for a standardized automation network in the plant, to which all other machines and devices can be connected. Even the integration of existing plant components, for example with PROFIBUS, presents no problems due to the use of network transitions.

Use of Web tools

Thanks to the unrestricted support of TCP/IP, PROFINET permits the use of standard Web services in the device, such as Web servers. Irrespective of the tool used, information from the automation level can be accessed from virtually any location using a commercially available Internet browser. This considerably simplifies commissioning and diagnostics. Users can then decide for themselves how much openness to the IT world they want to allow for their machine or plant. This means that PROFINET can be used simply as an isolated plant network or connected via appropriate security modules, such as the SCALANCE S modules, to the office network or the Internet. In this way, new remote maintenance concepts or the high-speed exchange of production data become possible.

Expandability

On the one hand, PROFINET facilitates the integration of existing systems and networks without any great effort or expense. In this way, PROFINET safeguards investments in existing plant components that communicate via PROFIBUS and other fieldbuses such as AS-Interface. On the other hand, additional PROFINET nodes can be added at any time. By using additional network components, network infrastructures can be expanded using cabling or wireless methods – even while the plant is operating.

Efficiency

Greater global competition means that companies must use their resources economically and efficiently. This applies in particular to production. This is where PROFINET ensures greater efficiency. Simple engineering guarantees fast commissioning, while reliable devices ensure a high level of plant availability. Comprehensive diagnostic and maintenance concepts help to reduce plant downtimes and keep maintenance costs to a minimum.

One cable for everything

PROFINET permits simultaneous fieldbus communication with isochronous mode and standard IT communication (TCP/IP) on one cable. This real-time communication for the transmission of the user/process data and diagnostic data takes place on a single cable. Specific profile communication (PROFIsafe, PROFIdrive and PROFlenergy) can be integrated without any additional cabling. This solution offers a wide scope of functions at a low level of complexity.

Device and network diagnostics

By retaining the tried and tested PROFIBUS device model, the same diagnostics information is available with PROFINET. In addition, module- and channel-specific data can also be read out from the devices during device diagnosis, enabling faults to be located quickly and easily. Apart from the availability of device information, the reliability of the network operation has top priority in the network management.

In existing networks the Simple Network Management Protocol (SNMP) has established itself as the de facto standard for the maintenance and monitoring of the network components and their functions. PROFINET uses this standard and gives users the opportunity to maintain their networks with tools that are familiar to them, such as the SINEMA Server network management software.

For easier maintenance of PROFINET devices, both on-site and remotely via a secure VPN connection, application-specific websites can be set up on the integrated Web server of the field devices using the familiar HTML standard.

Energy efficiency

En route to the green factory: PROFlenergy is a profile that provides functions and mechanisms for PROFINET field devices that support energy-efficient production.

The profile, which is defined by the PNO and is independent of any manufacturers or devices, enables the energy demand and costs to be significantly reduced: Using PROFlenergy, any specific loads that are not currently being used can be switched off. This achieves a noticeable reduction in energy costs during breaks in production. PROFlenergy permits the simple, automated activation and deactivation of technologically related plant components. It is coordinated centrally by means of a higher-level controller and is networked via PROFINET. This ensures that as much energy as possible is saved during longer breaks. Temporarily switching off plant components contributes to the even distribution and most efficient use of energy.

The use of PROFlenergy is made easy for the machine builder by its integration into familiar series of products. In addition, PROFlenergy is defined in such a way that the necessary function blocks can easily be integrated into existing automation systems at a later stage.

Simple wiring

Particularly stringent demands are made on the installation of cabling in the industrial environment. In addition, there is a requirement to set up industry-standard networks in the shortest possible time without any special knowledge.

With FastConnect, Siemens is offering a high-speed installation system that meets all of these requirements. FastConnect is the standard-compliant, industrial cabling system consisting of cables, connectors and assembly tools for PROFINET networks. The time required for connecting terminals is minimized by the simple installation method using just a single tool, while installation errors are prevented by the practical color-coding. Both copper cables and glass fiber optic cables can be easily assembled on site.

Fast device replacement

PROFINET devices are identified by means of a name assigned during configuration. On replacing a defective device, a new device can be recognized from its topology information by the IO controller and a new name can be assigned to it automatically. This means that no engineering tool is necessary for the replacement of equipment.

This mechanism can even be used for the initial commissioning of a complete system. This speeds up commissioning, particularly in the case of series machines.

Ruggedness

An automation network must be robustly protected against external sources of interference. The use of Switched Ethernet prevents faults in one part of the network from affecting the entire plant network. For areas that are particularly prone to radio frequency interference (RFI), PROFINET allows the use of fiber optic cables.

Highlights

Communication > PROFINET

Overview (continued)

Performance

Productivity and product quality determine the level of success in the market. Precise motion control, dynamic drives, high-speed controllers and the deterministic synchronization of devices are therefore key factors in achieving superior production. They facilitate high production rates and optimum product quality at the same time.

Speed and precision

Fast motion control applications demand precise and deterministic exchange of data. This is implemented by means of drive controllers using isochronous real time (IRT).

With IRT and isochronous mode, PROFINET permits fast and deterministic communication. This synchronizes the various cycles of a system (input, network, CPU processing and output), even in the case of parallel TCP/IP traffic. The short cycle times of PROFINET make it possible to raise the productivity of machines and plants and to guarantee the product quality and high level of precision.

The standardized PROFIdrive profile permits vendor-independent communication between CPUs and drives.

Large quantity structures

The use of PROFINET makes it possible to overcome the existing restrictions regarding the scope of machines and systems that can be implemented. In one network, several different controllers can interact with their assigned field devices. The number of field devices per PROFINET network is virtually unlimited – the entire range of IP addresses is available.

High data rate

By using 100 Mbit/s in full duplex mode, PROFINET achieves a significantly higher data rate than previous fieldbuses. This means that other plant data can be transmitted over TCP/IP without any problems, in addition to the process data. PROFINET therefore meets the combined industrial demands for simultaneously transmitting high-speed IO data and large volumes of data for additional sections of the application. Even the transmission of large volumes of data, such as that from cameras, has no adverse effect on the speed and precision of the IO data transmission, thanks to PROFINET mechanisms.

Media redundancy

A higher plant availability can be achieved with a redundant installation (ring topology). The media redundancy can be implemented not only with the aid of external switches, but also by means of integrated PROFINET interfaces. Using the media redundancy protocol (MRP), reconfiguration times of 200 ms can be achieved. If the communication is interrupted in just one part of the ring installation this means that a plant standstill is prevented and any necessary maintenance or repair work can be performed without any time pressure.

For motion control applications, PROFINET IRT in ring topologies offers the extended media redundancy for planned duplication (MRPD) which operates in a bumpless mode without any re-configuration time. If communication is interrupted (e.g. a cable break) the process can continue operating without interruption. Until now, the functionality has only been supported by SIMOTION, SINAMICS and SCALANCE X200IRT.

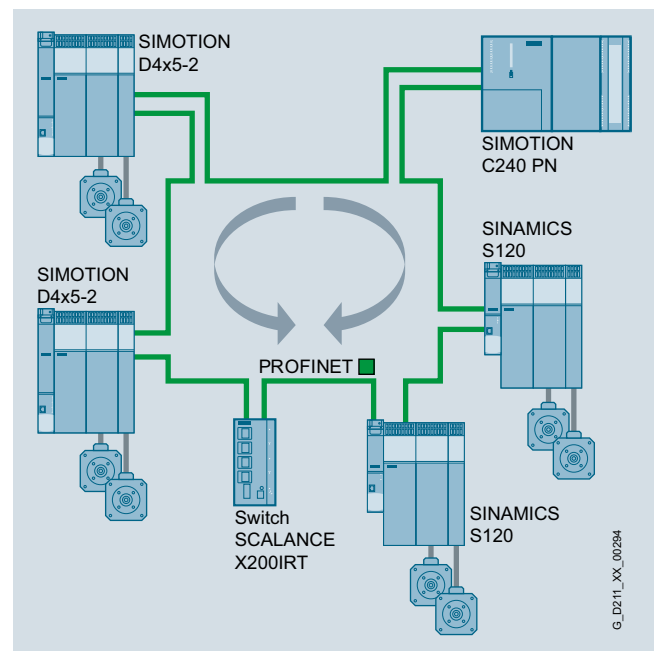

Bumpless media redundancy illustrated by example of SINAMICS S120 with SIMOTION and SCALANCE X200IRT

Benefits

- PROFINET is the open Industrial Ethernet standard for automation
- PROFINET is based on Industrial Ethernet
- PROFINET uses TCP/IP and IT standards
- PROFINET is real-time Ethernet
- PROFINET enables seamless integration of fieldbus systems
- PROFINET supports fail-safe communication via PROFIsafe and also via IWLAN

More information

Further information is available at www.siemens.com/profinet

Overview

PROFINET – Functions of SIMOTION motion controllers

SIMOTION device	C240 PN	D410-2 DP/PN	D425-2 DP/PN	D435-2 DP/PN	D445-2 DP/PN	D455-2 DP/PN	P320-4 ¹⁾
Number of PROFINET interfaces	1	1	1 ... 2 (second interface is an option)	1 ... 2 (second interface is an option)	1 ... 2 (second interface is an option)	1 ... 2 (second interface is an option)	1
Interface 1							
PROFINET with IRT (isochronous mode)	✓	✓	✓	✓	✓	✓	✓
Number of ports	3	2	3	3	3	3	3
Max. number of devices	64	64	64	64	64	64	64
Min. send clock in ms	0.5	0.25	0.25	0.25	0.25	0.25	0.25
I-Device	✓	✓	✓	✓	✓	✓	✓
Shared I-Device ¹⁾	✓	✓	✓	✓	✓	✓	✓
Bumpless media redundancy (MRPD) ¹⁾²⁾	✓	✓	✓	✓	✓	✓	✓
Step-change media redundancy (MRP)	✓	✓	✓	✓	✓	✓	✓
PROFIsafe routing	✓	✓	✓	✓	✓	✓	✓
PROFInergy (as controller)	✓	✓	✓	✓	✓	✓	✓
PROFInergy (as device)	✓	✓	✓	✓	✓	✓	✓
Interface 2 (option) ³⁾							
PROFINET with IRT (isochronous mode)	–	–	✓	✓	✓	✓	–
Number of ports (CBE30-2 option board)	–	–	4	4	4	4	–
Max. number of devices	–	–	64	64	64	64	–
Min. send clock in ms	–	–	0.25	0.25	0.25	0.25	–
I-Device	–	–	✓	✓	✓	✓	–
Shared I-Device ¹⁾	–	–	✓	✓	✓	✓	–
Bumpless media redundancy (MRPD) ¹⁾	–	–	✓	✓	✓	✓	–
Step-change media redundancy (MRP)	–	–	✓	✓	✓	✓	–
PROFIsafe routing	–	–	✓	✓	✓	✓	–
PROFInergy (as controller)	–	–	✓	✓	✓	✓	–
PROFInergy (as device)	–	–	✓	✓	✓	✓	–

PROFINET – Functions of the SINAMICS S120/SINAMICS S150 Control Units

SINAMICS S120/SINAMICS S150	CU320-2 PN	CU320-2 DP (CBE20)	CU310-2 PN
PROFINET with IRT (isochronous mode)	✓	✓	✓
Number of ports	2	4	2
Min. send clock in ms	0.25	0.5	0.25
Shared device	✓	✓	✓
Bumpless media redundancy (MRPD)	✓	✓	✓
Step-change media redundancy (MRP)	✓	✓	✓
PROFIsafe	✓	✓	✓
PROFInergy	✓	✓	✓
PROFIdrive	✓	✓	✓

PROFINET for SIMOTION and SINAMICS S120/SINAMICS S150

SIMOTION and SINAMICS S120/SINAMICS S150 are fully integrated in the PROFINET communication. Interaction with the following PROFINET components is possible:

- Distributed I/O on SIMOTION
- SINAMICS S120/SINAMICS S150 on SIMATIC S7-CPU or SIMOTION
- SIMOTION as IO-Device on SIMATIC S7-CPU
- Active network components (e.g. SCALANCE) with SIMOTION and SINAMICS 120/SINAMICS S150
- Wireless with SIMOTION and SINAMICS S120/SINAMICS S150

When an automation topology is configured, the real-time classes RT and IRT can be used alongside each other on the same network or cable. It must, however, be noted that not all devices support both real-time classes RT and IRT. For devices that should be synchronized with IRT, it is important that all the PROFINET components that lie in between support the IRT real-time class.

¹⁾ Not supported by SCOUT TIA.

²⁾ To establish bumpless media redundancy (MRPD), a separate switch from the SCALANCE X200IRT series is required.

³⁾ Optional second PROFINET interface over CBE30-2 (4 ports), only with SIMOTION D4x5-2 DP/PN.

Highlights

Communication > PROFIdrive

Overview

PROFIdrive – the standardized drive interface for PROFINET and PROFIBUS

PROFIdrive defines the device behavior and technique to access internal device data for electric drives connected to PROFINET and PROFIBUS – from basic frequency converters up to high-performance servo controllers.

It describes in detail the practical use of communication functions – slave-to-slave data transfer, equidistance and clock cycle synchronization (isochronous mode) in drive applications. In addition, it specifies all device characteristics which influence interfaces connected to a controller over PROFINET or PROFIBUS. This also includes the state machine (sequence control), the encoder interface, scaling of values, definition of standard telegrams, access to drive parameters etc.

The PROFIdrive profile supports both central as well as distributed motion control concepts.

What are profiles?

For devices and systems used in automation technology, profiles define properties and modes of behavior. This allows manufacturers and users to define common standards. Devices and systems that comply with such a cross-manufacturer profile, are interoperable on a fieldbus and, to a certain degree, can be interchanged.

Are there different types of profiles?

A distinction is made between what are known as application profiles (general or specific) and system profiles:

- Application profiles (also device profiles) predominantly refer to devices (e.g. drives) and include and agreed selection regarding bus communication as well as also specific device applications.
- System profiles describe classes of systems, including master functionality, program interfaces and integration resources.

Is PROFIdrive fit for the future?

PROFIdrive has been specified by the PROFIBUS and PROFINET International (PI) user organization, and is specified as a standard that is fit for the future through standard IEC 61800-7.

The basic philosophy: Keep it simple

The PROFIdrive profile tries to keep the drive interface as simple as possible and free from technology functions. As a result of this philosophy, referencing models as well as the functionality and performance of the PROFINET/PROFIBUS master have either no influence or only a low influence on the drive interface.

One drive profile – different application classes

The integration of drives into automation solutions depends very strongly on the particular drive application. In order to be able to address the complete, huge bandwidth of drive applications – from basic frequency converters up to synchronized multi-axis systems with a high dynamic performance – using just one profile, PROFIdrive defines six application classes, to which most drive applications can be assigned:

- Class 1 – standard drives (for example pumps, fans, agitators etc.)
- Class 2 – standard drives with technological functions
- Class 3 – positioning drives
- Class 4 – motion control drives with central, higher-level motion control intelligence and patented position control concept "dynamic servo control"
- Class 5 – motion control drives with central, higher-level motion control intelligence and position setpoint interface
- Class 6 – motion control drives with distributed motion control intelligence integrated in the drives themselves

Design

The device model of PROFIdrive

PROFIdrive defines a device model based on function modules which cooperate in the device and generate the intelligence of the drive system. These modules have objects assigned to them which are described in the profile and are defined with respect to their functions. The overall functionality of a drive is therefore described through the sum of its parameters.

In contrast to other drive profiles, PROFIdrive defines only the access mechanisms to the parameters as well as a subset of profile parameters (approx. 30) such as the fault buffer, drive control and device identification.

All other parameters are vendor-specific which gives drive manufacturers great flexibility with respect to implementing function modules. The elements of a parameter are accessed acyclically via data records.

As a communication protocol, PROFIdrive uses DP-V0, DP-V1, and the DP-V2 expansions for PROFIBUS including the functions "Slave-to-Slave Communication" and "Isochronous Operation", or PROFINET IO with real-time classes RT and IRT.

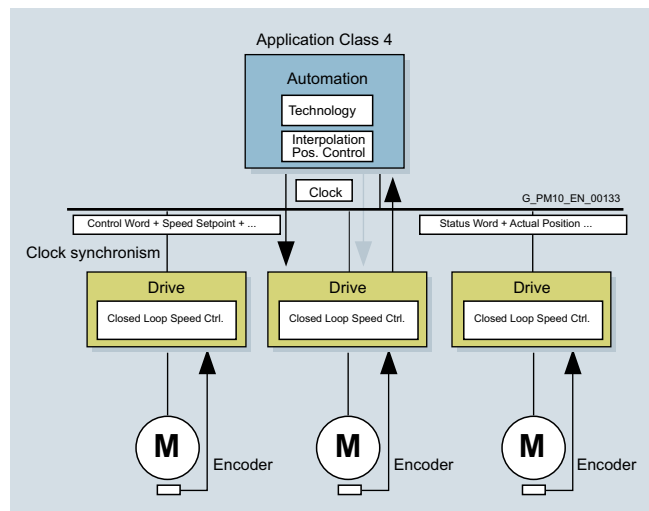

More information

Further information on PROFINET and PROFIBUS is available at www.profinet.com

See under Download / Technical description & books / PROFIdrive – Technology and Application - System Description

Overview

As simple fieldbus protocols, USS (Universal Serial Interface protocol of Siemens AG, 1992) and Modbus RTU can be used both cyclically and acyclically. Based on RS485 physical bus characteristics, up to 32 nodes can be networked to one bus

segment and connected to a higher-level controller. These protocols are used when there are limited demands on data throughput.

Overview

CANopen is a communication protocol based on CAN physical characteristics, which is predominantly used in the automation industry and for networking within complex devices. Originally conceived as a fieldbus for networking devices in motion control applications such as handling systems, CANopen has since established itself in the field of medical engineering, vehicle automation, rail and ship networking as well as building automation.

Interoperability of CANopen is ensured through the use of application and device profiles, whereby the wide range of options offered by the bus specification enables an appropriate, precise selection to be made for the application or device in question. Furthermore, converters with CANopen support the "CiA 402 Electrical Drives" device profile.

Overview

Ethernet Industrial Protocol (EtherNet/IP) is an open standard for industrial networks. EtherNet/IP is used to transmit cyclic I/O data and acyclic parameter data. EtherNet/IP was developed by Rockwell Automation and the ODVA (Open DeviceNet Vendor

Association), and belongs to the international standard series IEC 61158. EtherNet/IP is a popular communication standard, particularly in the American market and in the Rockwell controllers environment.

Highlights

Notes

2

SINAMICS S120

Chassis Format Converter Units



3/2 System overview

- 3/2 Overview
- 3/4 Function
- 3/5 Technical specifications

3/6 Air-cooled units

- 3/6 Technical specifications
- 3/8 Characteristic curves
- 3/11 Power Modules
- 3/15 Basic Line Modules
- 3/20 Smart Line Modules
- 3/25 Active Line Modules
- 3/30 Active Interface Modules
- 3/36 Motor Modules
- 3/53 Mounting device for power blocks

3/54 Liquid-cooled units

- 3/54 Overview
- 3/55 Technical specifications
- 3/58 Characteristic curves
- 3/62 Power Modules
- 3/66 Basic Line Modules
- 3/70 Active Line Modules
- 3/74 Active Interface Modules
- 3/78 Motor Modules

3/88 System components

- 3/88 Line-side power components
- 3/89 Line filter
- 3/93 Line reactors
- 3/97 Recommended line-side system components
- 3/103 DC link components
- 3/103 Braking Modules
- 3/107 Braking resistors
- 3/109 DC link fuses
- 3/111 Motor-side power components
- 3/111 Motor reactors
- 3/115 du/dt filters plus VPL
- 3/120 du/dt filters compact plus VPL
- 3/125 Sine-wave filters
- 3/127 Control Units
- 3/130 CU320-2 Control Unit
- 3/134 CompactFlash card for CU320-2
- 3/136 CU310-2 Control Unit
- 3/140 CompactFlash card for CU310-2
- 3/141 Supplementary system components
- 3/141 BOP20 Basic Operator Panel
- 3/142 AOP30 Advanced Operator Panel
- 3/144 CBC10 Communication Board
- 3/145 CBE20 Communication Board
- 3/146 DMC20 DRIVE-CLiQ Hub Module
- 3/148 DME20 DRIVE-CLiQ Hub Module
- 3/150 TB30 Terminal Board
- 3/152 TM15 Terminal Module
- 3/154 TM31 Terminal Module
- 3/157 TM41 Terminal Module
- 3/160 TM54F Terminal Module
- 3/163 TM120 Terminal Module
- 3/165 TM150 Terminal Module
- 3/167 VSM10 Voltage Sensing Module
- 3/169 Safe Brake Adapter SBA
- 3/171 Encoder system connection
- 3/172 SMC10 Sensor Module Cabinet-Mounted
- 3/173 SMC20 Sensor Module Cabinet-Mounted
- 3/174 SMC30 Sensor Module Cabinet-Mounted
- 3/175 Connection system
- 3/175 Signal cables

SINAMICS S120 Chassis Format Converter Units

System overview

Overview



With its separate power unit and Control Unit, the SINAMICS S120 drive system can be perfectly adapted to a wide variety of different drive tasks.

The Control Unit is selected according to the number of drives to be controlled and the required performance level, while the power unit must be rated to meet the energy requirements of the system. The connection between the Control Unit and power unit is made very simply using the DRIVE-CLiQ digital system interface.

The following drive units are available in the chassis format:

- Power Modules
- Basic Line Modules
- Smart Line Modules (only available in the air-cooled version)
- Active Line Modules
- Active Interface Modules
- Motor Modules

Power Modules

The simplest version of a SINAMICS S120 drive system comprises a CU310-2 Control Unit and a Power Module.

In Power Modules specifically designed for single drives without regenerative feedback into the line supply, the line-side infeed and the motor-side power unit are combined in one unit.

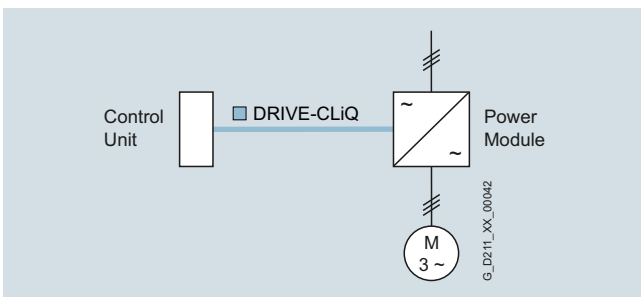

Generated energy produced during braking is converted to heat in braking resistors.

The Control Unit is plugged onto the Power Module; in addition to the complete control intelligence, the Control Unit also has all the drive interfaces for communication with higher-level systems and interfacing of add-on components.

Line Modules

Line Modules contain the central line infeed for the DC link. Various Line Modules can be selected to address the various application profiles:

- Basic Line Modules
- Smart Line Modules
- Active Line Modules

Basic Line Modules

Basic Line Modules are designed only for infeed operation, i.e. they are not capable of recovering energy to the line supply. If regenerative energy is produced, e.g. when drives brake, it must be converted to heat by means of a Braking Module and a braking resistor.

A line filter can be optionally installed in order to ensure compliance with the limits stipulated for Class C2 in EN 61800-3.

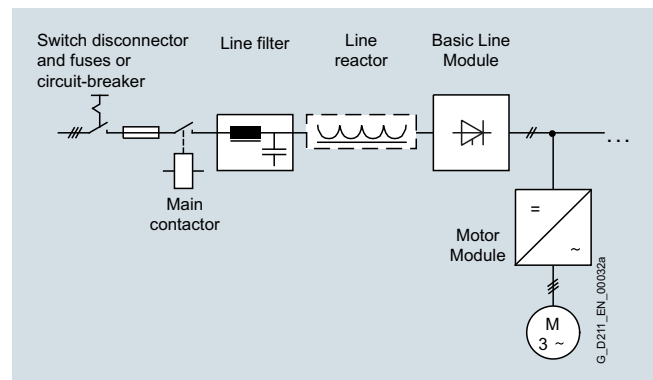

Smart Line Modules

Smart Line Modules can supply energy and return regenerative energy to the supply system. A Braking Module and braking resistor are required only if the drives need to be decelerated in a controlled manner after a power failure (i.e. when energy cannot be recovered to the supply). When a Smart Line Module is used as the infeed, the matching line reactor must be installed. A line filter can be optionally installed in order to ensure compliance with the limits stipulated for Class C2 in EN 61800-3.

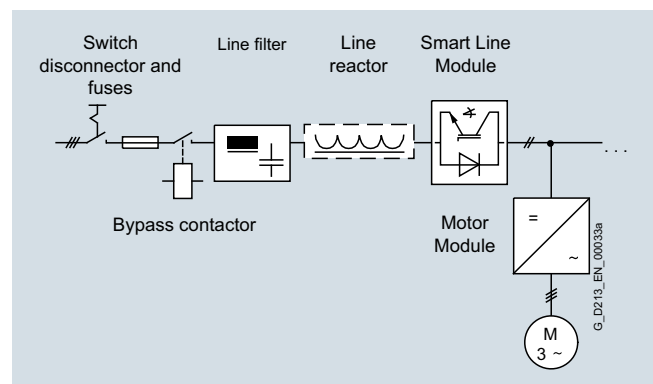

Overview (continued)**Active Line Modules**

Active Line Modules can supply energy and return regenerative energy to the supply system. A Braking Module and braking resistor are required only if the drives need to be decelerated in a controlled manner after a power failure (i.e. when energy cannot be recovered to the supply).

In contrast to Basic Line Modules and Smart Line Modules, Active Line Modules generate a controlled DC voltage that is kept constant despite fluctuations in the line supply voltage if the line supply voltage fluctuates within the permitted tolerance range. Active Line Modules draw a virtually sinusoidal current from the supply which limits any harmful harmonics. All the components required to operate an Active Line Module are integrated in the Active Interface Module.

A line filter can be optionally installed in order to ensure compliance with the limits stipulated for Class C2 in EN 61800-3.

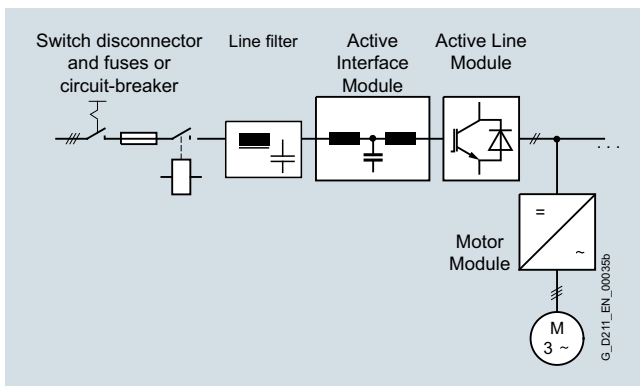
**Motor Modules**

A voltage DC link and an inverter for supplying a motor are integrated in the Motor Module.

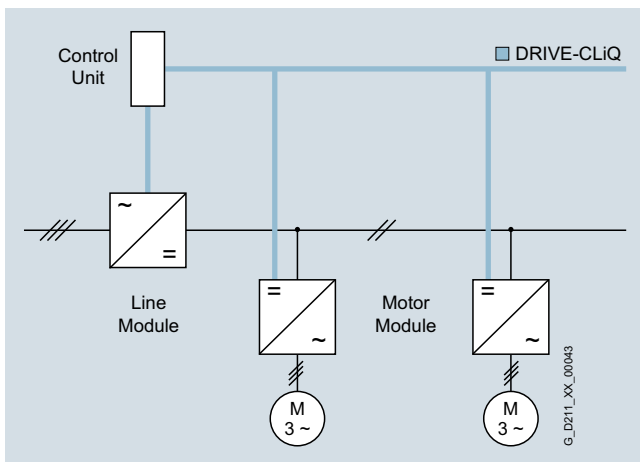

Motor Modules are designed for multi-axis drive systems and are controlled by either a CU320-2 or a SIMOTION D Control Unit. Motor Modules are interconnected through the DC link.

One or several Motor Modules are supplied with energy for the motors via the DC link. Both synchronous and induction motors can be operated.

Since the Motor Modules share the same DC link, they can exchange energy with one another, i.e. if one Motor Module operating in generator mode produces energy, the energy can be used by another Motor Module operating in motor mode. The DC link is supplied with line supply voltage by a Line Module.

Control Units

The control intelligence for all the drive axes integrated in the multi-axis group is combined in the Control Units. They also feature drive-related inputs/outputs and interfaces for communicating with higher-level controllers. Control Units are available with different ranges of functions and with different performance levels.

System components

The structure of the drive system is defined by selecting the Control Unit and Power Module or Line Module and Motor Modules. The additional components provided allow optimum adaptation of the drive system to the application.

These components are subdivided into:

- **Line-side components**, e.g. line reactors and line filters
- **DC link components** e.g. Braking Modules and braking resistors
- **Motor-side components**, e.g. motor reactors and dv/dt filters plus VPL, sine-wave filters
- **Supplementary system components**, e.g. Terminal Modules, Operator Panels, and Communication Boards
- **Encoder system interface** for connecting various encoder types to SINAMICS S120

DRIVE-CLiQ – the digital interface between the components

SINAMICS S120 components, including motors and encoders, are equipped with the high-performance DRIVE-CLiQ system interface.

Line and Motor Modules for example are connected to the Control Unit – and Terminal Modules and Sensor Modules to the drive system via DRIVE-CLiQ – simply and efficiently. Motors that also have this interface can be directly connected to the drive system.

Converter boards (Sensor Modules) for converting standard encoder signals to DRIVE-CLiQ are available for third-party motors or retrofit applications.

The electronic rating plate

An important digital linkage element of the SINAMICS S120 drive system are the electronic type plates integrated in every component. They allow all drive components to be automatically identified via the DRIVE-CLiQ link.

The electronic type plate contains all the relevant technical data about that particular component. In addition to the technical data, the type plate includes logistical data (manufacturer ID, article number and ID). Since this data can be called up electronically on site or remotely, all the components used in a machine can always be individually identified, which helps simplify servicing.

SINAMICS S120 Chassis Format Converter Units

System overview

Overview (continued)

Painted modules

The following devices are equipped as standard with coated modules:

- Blocksize format units
- Booksize format units
- Chassis format units
- Control Units
- Sensor Modules
- Terminal Modules
- Advanced Operator Panel (AOP30)

The coating on the modules protects the sensitive SMD components against corrosive gases, chemically active dust and moisture.

Nickel-plated busbars

All of the copper busbars used are nickel-plated in order to achieve the best possible immunity to environmental effects. Further, it is possible to eliminate having to clean the contacts at the customer connections, which is required for bare copper connections.

Note:

For some components, parts of the copper busbars cannot be nickel-plated for technical reasons.

Software and protective functions	Description
Setpoint input	The setpoint can be specified both internally and externally; internally as a fixed setpoint, motorized potentiometer setpoint or jog setpoint, externally via the communications interface or an analog input. The internal fixed setpoint and the motorized potentiometer setpoint can be switched or adjusted via control commands from any interface.
Motor identification	The automatic motor identification function makes commissioning faster and easier and optimizes closed-loop control of the drive.
Ramp-function generator	A user-friendly ramp-function generator with separately adjustable ramp-up and ramp-down times, together with adjustable rounding times in the lower and upper speed ranges, allows the drive to be smoothly accelerated and braked. This results in a good speed control response and contributes to the reduction of stress on the mechanical system. The down ramp can be parameterized separately for a quick stop.
V_{dc max} controller	The V _{dc max} controller automatically prevents overvoltages in the DC link, if the set down ramp is too short, for example. This may also extend the set ramp-down time. Note: This function only makes sense for single-axis applications.
Kinetic buffering (KIP)	For brief line supply failures, the kinetic energy of the rotating drive is used to buffer the DC link and therefore prevents fault trips. The drive converter remains operational as long as the drive can provide regenerative energy as a result of its motion and the DC link voltage does not drop below the shutdown threshold. When the line supply recovers within this time, the drive is again bumplessly accelerated up to its setpoint speed.
Automatic restart	The automatic restart switches the drive on again when the power is restored after a power failure, and ramps up to the current speed setpoint.
Flying restart	The flying restart function allows the converter to be switched to a motor that is still turning. With the voltage sensing capability provided by the optional VSM10, the flying restart time for large induction motors can be significantly reduced because the motor does not need to be de-magnetized.
Technology controller	Using the technology controller (PID controller) function module, level or flow controls and complex tension controls can be implemented, for example. The existing D component can act both on the system deviation well as on the actual value (factory setting). The P, I, and D components are set separately.
Free function blocks	Using the freely programmable function blocks, it is easy to implement logic and arithmetic functions for controlling the SINAMICS drive. The blocks can be programmed at the operator panel or the STARTER commissioning tool.
Drive Control Chart (DCC)	Drive Control Chart (DCC) is an additional tool for the easy configuration of technological functions for SINAMICS. The block library contains a large selection of control, arithmetic and logic blocks as well as extensive open-loop and closed-loop control functions. The user-friendly DCC editor enables easy graphics-based configuration, allows control loop structures to be clearly represented and provides a high degree of reusability of charts that have already been created. DCC is an add-on to the STARTER commissioning tool (→ Tools and Engineering).
P_t sensing for motor protection	A motor model stored in the converter software calculates the motor temperature based on the current speed and load. More exact measurement of the temperature, which also takes into account the influence of the ambient temperature, is possible by means of direct temperature measurement using KTY84 sensors in the motor winding.
Motor temperature evaluation	Motor protection by evaluating a KTY84, PTC or Pt100 temperature sensor. When a KTY84 temperature sensor is connected, the limit values can be set for alarm or shutdown. When a PTC thermistor is connected, the system reaction to triggering of the thermistor (alarm or trip) can be defined.
Motor blocking protection	A blocked motor is detected and protected against thermal overloading by a fault trip.

Function

Communication with higher-level controller and customer terminal block

As customer interface to a higher-level control, as standard there is a PROFIBUS or PROFINET communication interface on the Control Unit CU320-2; there are also expansions such as the Terminal Module TM31, the Terminal Board TB30 and modules to communicate via CANopen or EtherNet/IP.

These interfaces can be used to connect the system to the higher-level controller using analog and digital signals, or to connect additional units.

For additional information, please refer to the [SINAMICS Low Voltage Engineering Manual](#).

Open-loop and closed-loop control functions

SINAMICS S120 can use a dynamic, high-precision closed-loop vector control (drive object type VECTOR), or a highly dynamic closed-loop servo control (drive object type SERVO).

Software and protective functions

The software functions available as standard are described below:

Function (continued)

Software and protective functions	Description
Brake control	"Simple brake control" for control of holding brakes: The holding brake is used to secure drives against unwanted motion when deactivated. "Extended brake control" function module for complex brake control, e.g. for motor holding brakes and operational brakes: When braking with a feedback signal, the brake control reacts to the feedback signal contacts of the brake.
Write protection	Write protection to prevent unintentional changing of the setting parameters (without password function).
Know-how protection	Know-how protection for encrypting stored data, e.g. to protect configuration know-how, and to protect against changes and duplication (with password function).
Web server	The integrated web server provides information about the drive unit via its web pages. The web server is accessed using a web browser via unsecured (http) or secured transfer protocol (https).

Power unit protection

Power unit protection	Description
Ground fault monitoring at the output	A ground fault at the output is detected by a total current monitor and results in shutdown in grounded systems.
Electronic short-circuit protection at the output	A short-circuit at the output (e.g. at the converter output terminals, in the motor cable or in the motor terminal box) is detected and the converter shuts down with a "fault".
Thermal overload protection	An alarm is issued first when the overtemperature threshold responds. If the temperature continues to rise, the unit either shuts down or independently adjusts the pulse frequency or output current so that thermal load is reduced. Once the cause of the fault has been eliminated (e.g. cooling has been improved), the original operating values are automatically resumed.

Technical specifications

The most important directives and standards are listed below. These are used as the basis for the SINAMICS S120 built-in units in chassis format and they must be carefully observed to achieve an EMC-compliant configuration that is safe both functionally and in operation.

European directives	
2006/95/EC	Low Voltage Directive: Directive of the European Parliament and Council of December 12, 2006, on the approximation of the laws of the member states relating to electrical equipment designed for use within certain voltage limits
2004/108/EC	EMC directive: Directive of the European Parliament and Council of December 15, 2004, which repeals directive 89/336/EEC, on the approximation of laws of the member states relating to electromagnetic compatibility
2006/42/EC	Machinery directive: Directive of the European Parliament and Council of May 17, 2006 on machinery and for changing Directive 95/16/EC (amendment)
European standards	
EN ISO 3744	Acoustics – Determination of the sound power level and sound energy level for noise sources that result from sound pressure measurements – envelope surface procedure of the accuracy class 2 for a largely free sound field over a reflecting plane
EN ISO 13849-1	Safety of machinery – safety-related parts of control systems; Part 1: General design guidelines (ISO 13849-1: 2006) (replaces EN 954-1)
EN 60146-1-1	Semiconductor converters – General requirements and line-commutated converters Part 1-1: Specification of basic requirements
EN 60204-1	Safety of machinery – Electrical equipment of machines; Part 1: General requirements
EN 60529	Degrees of protection provided by enclosures (IP code)
EN 61508-1	Functional safety of electrical/electronic/programmable electronic safety-related systems Part 1: General requirements
EN 61800-2	Adjustable speed electrical power drive systems Part 2: General requirements – Rating specifications for low voltage adjustable frequency AC power drive systems
EN 61800-3	Adjustable speed electrical power drive systems Part 3: EMC requirements and specific test methods
EN 61800-5-1	Adjustable speed electrical power drive systems Part 5: Safety requirements Main section 1: Electrical and thermal requirements
EN 61800-5-2	Adjustable speed electrical power drive systems Part 5-2: Safety requirements – Functional safety (IEC 61800-5-2: 2007)
North American standards	
UL 508A	Industrial Control Panels
UL 508C	Power Conversion Equipment
CSA C22.2 No. 14	Industrial Control Equipment
Approvals	
cULus, cURus	Testing by UL (Underwriters Laboratories, www.ul.com) according to UL and CSA standards

Mark of conformity and UL Files:
(→ Appendix, Approvals)

SINAMICS S120 Chassis Format Converter Units

Air-cooled units

Technical specifications

General technical specifications

Unless clearly specified otherwise, the following technical data are valid for all the following components of the air-cooled SINAMICS S120 drive system in the chassis format.

Electrical specifications	
Rated voltages	380 ... 480 V 3 AC, $\pm 10\%$ ($-15\% < 1$ min) 500 ... 690 V 3 AC, $\pm 10\%$ ($-15\% < 1$ min)
Line supply types	Grounded TN/TT systems and non-grounded IT systems
Line frequency	47 ... 63 Hz
Overvoltage category	III to EN 61800-5-1
Electronics power supply	24 V DC, -15% $+20\%$ implemented as PELV circuit in accordance with EN 61800-5-1 Ground = negative pole grounded via the electronics
Rated short-circuit current per IEC, in conjunction with the specified fuses or circuit breakers	
Rated power	
• 1.1 ... 447 kW	65 kA
• 448 ... 671 kW	84 kA
• 672 ... 1193 kW	170 kA
• > 1194 kW	200 kA
Rated short-circuit current SCCR (Short Circuit Current Rating) according to UL508C (up to 600 V), in conjunction with the specified fuses or circuit breakers	
Rated power	
• 1.1 ... 447 kW	65 kA
• 448 ... 671 kW	84 kA
• 672 ... 1193 kW	170 kA
• > 1194 kW	200 kA
Control method	Vector/servo control with and without encoder or V/f control
Fixed speeds	15 fixed speeds plus 1 minimum speed, parameterizable (in the default setting, 3 fixed setpoints plus 1 minimum speed are selectable using terminal block/PROFIBUS/PROFINET)
Skippable speed ranges	4, parameterizable
Setpoint resolution	0.001 rpm digital (14 bits + sign) 12 bits analog
Braking operation	With Active Line Modules and Smart Line Modules, four-quadrant operation as standard (energy recovery). With Basic Line Modules, two-quadrant operation as standard, braking by means of an optional braking chopper, or alternatively by a Motor Module.
Mechanical specifications	
Degree of protection	IP00 or IP20 depending on type
Protection class	I acc. to EN 61800-5-1
Touch protection	EN 50274 / BGV A3 when used for the intended purpose
Cooling method	Forced air cooling AF according to EN 60146

SINAMICS S120 Chassis Format Converter Units

Air-cooled units

Technical specifications (continued)

Ambient conditions	Storage ¹⁾	Transport ¹⁾	Operation
Ambient temperature	-25 ... +55 °C Class 1K4 acc. to EN 60721-3-1	<u>-25</u> ... +70 °C Class 2K4 acc. to EN 60721-3-2	Line-side components, Power Modules, Line Modules and Motor Modules: 0 ... 40 °C without derating Up to 55 °C, see derating data Control Units, supplementary system components, and Sensor Modules: 0 ... 55 °C (for operation in control cabinet) DC link components and motor-side components: 0 ... 55 °C
Relative humidity Condensation, splashwater, and ice formation not permitted (EN 60204, Part 1)	<u>5 ... 95 %</u> Class 1K4 acc. to EN 60721-3-1	5 ... 95 % at 40 °C Class 2K3 acc. to EN 60721-3-2	5 ... 95 % Class 3K3 acc. to EN 60721-3-3
Environmental class/ harmful chemical substances	Class 1C2 acc. to EN 60721-3-1	Class 2C2 acc. to EN 60721-3-2	Class 3C2 acc. to EN 60721-3-3
Organic/ biological influences	Class 1B1 acc. to EN 60721-3-1	Class 2B1 acc. to EN 60721-3-2	Class 3B1 acc. to EN 60721-3-3
Degree of pollution	2 acc. to EN 61800-5-1		
Installation altitude	Up to 2000 m above sea level without derating >2000 m above sea level, see derating data		
Mechanical stability	Storage ¹⁾	Transport ¹⁾	Operation
Vibratory load	–	Class 2M2 acc. to EN 60721-3-2	Test values acc. to EN 60068-2-6 test Fc: <ul style="list-style-type: none"> • 10 ... 58 Hz with constant deflection 0.075 mm • 58 ... 150 Hz with constant acceleration 9.81 m/s² (1 × g)
Shock load	–	Class 2M2 acc. to EN 60721-3-2	Test values according to EN 60068-2-27 test Ea: 98 m/s ² (10 × g)/20 ms
Compliance with standards			
Conformances/ approvals, according to	CE (EMC Directive No. 2004/108/EC, Low Voltage Directive No. 2006/95/EC and Machinery Directive 2006/42/EC for functional safety) C-Tick cULus (only for devices connected to line supply voltages 380 ... 480 V 3 AC and 500 ... 600 V 3 AC)		
Radio interference suppression	SINAMICS drive converter systems are not designed for connection to the public grid (first environment). Radio interference suppression is compliant with the EMC product standard for variable-speed drives EN 61800-3, "Second environment" (industrial networks). EMC disturbances can occur when connected to the public power networks. However, if additional measures are taken (e.g. → line filter), it can also be operated in the "first environment".		

Deviations from the specified class are underlined.

¹⁾ In transport packaging.

SINAMICS S120 Chassis Format Converter Units

Air-cooled units

Characteristic curves

Derating data, chassis format

Air-cooled SINAMICS G120 chassis format units and the associated system components are rated for an ambient temperature of 40 °C and installation altitudes up to 2000 m above sea level.

At ambient temperatures > 40 °C, the output current must be reduced. Ambient temperatures above 55 °C are not permissible.

At installation altitudes > 2000 m above sea level, it must be taken into account that the air pressure, and therefore air density, decreases as the height increases. As a consequence, the cooling efficiency and the insulation capacity of the air also decrease.

Due to the reduced cooling efficiency, it is necessary, on the one hand, to reduce the ambient temperature and on the other hand, to reduce the heat loss in the built-in unit by reducing the output

current, whereby ambient temperatures lower than 40 °C may be offset to compensate.

The following table lists the permissible output currents depending on the installation altitude and ambient temperature. The specified values already include a permitted compensation in respect of installation altitude and ambient temperatures < 40 °C (temperature at the air intake of the built-in unit).

The values apply under the precondition that a cooling air flow through the devices is guaranteed as specified in the technical specifications.

As additional measure for installation altitudes from 2000 m up to 5000 m, an isolating transformer is required in order to reduce transient overvoltages according to EN 60664-1.

For additional information, please refer to the [SINAMICS Low Voltage Engineering Manual](#).

Current-derating factors for SINAMICS S120 chassis units as a function of the ambient/air intake temperature and the installation altitude

Installation altitude above sea level m	Current derating factor (as a percentage of the rated current) for an ambient / air intake temperature of							
	20 °C	25 °C	30 °C	35 °C	40 °C	45 °C	50 °C	55 °C
0 ... 2000						93.3 %	86.7 %	80.0 %
2001 ... 2500					96.3 %			
2501 ... 3000		100 %		98.7 %				
3001 ... 3500				96.3 %				
3501 ... 4000								
4001 ... 4500		97.5 %						
4501 ... 5000	98.2 %							

Current derating for Power Modules and Motor Modules in chassis format as a function of the pulse frequency

To reduce motor noise or to increase output frequency, the pulse frequency can be increased relative to the factory setting (1.25 kHz or 2 kHz). When the pulse frequency is increased, the derating factor of the output current must be taken into account. This derating factor must be applied to the currents specified in the technical specifications.

For additional information, please refer to the [SINAMICS Low Voltage Engineering Manual](#).

The following table lists the rated output currents of the SINAMICS S120 Power Modules and Motor Modules with pulse frequency set in the factory as well as the current derating factors (permissible output currents referred to the rated output current) for higher pulse frequencies.

Derating factor of the output current as a function of the pulse frequency for units with a rated pulse frequency of 2 kHz

Power Module Motor Module	Type rating at 400 V kW	Output current at 2 kHz A	Derating factor at pulse frequency				
			2.5 kHz	4 kHz	5 kHz	7.5 kHz	8 kHz
380 ... 480 V 3 AC							
1TE32-1AA3	110	210	95 %	82 %	74 %	54 %	50 %
1TE32-6AA3	132	260	95 %	83 %	74 %	54 %	50 %
1TE33-1AA3	160	310	97 %	88 %	78 %	54 %	50 %
1TE33-8AA3	200	380	96 %	87 %	77 %	54 %	50 %
1TE35-0AA3	250	490	94 %	78 %	71 %	53 %	50 %

SINAMICS S120 Chassis Format Converter Units

Air-cooled units

Characteristic curves (continued)

Derating factor of the output current as a function of the pulse frequency for units with a rated pulse frequency of 1.25 kHz

Motor Module	Type rating at 400 V or 690 V kW	Output current at <u>1.25 kHz</u> A	Derating factor at pulse frequency				
			2 kHz	2.5 kHz	4 kHz	5 kHz	7.5 kHz
380 ... 480 V 3 AC							
1TE36-1AA3	315	605	83 %	72 %	64 %	60 %	40 %
1TE37-5AA3	400	745	83 %	72 %	64 %	60 %	40 %
1TE38-4AA3	450	840	87 %	79 %	64 %	55 %	40 %
1TE41-0AA3	560	985	92 %	87 %	70 %	60 %	50 %
1TE41-2AA3	710	1260	92 %	87 %	70 %	60 %	50 %
1TE41-4AA3	800	1405	97 %	95 %	74 %	60 %	50 %
500 ... 690 V 3 AC							
1TG28-5AA3	75	85	93 %	89 %	71 %	60 %	40 %
1TG31-0AA3	90	100	92 %	88 %	71 %	60 %	40 %
1TG31-2AA3	110	120	92 %	88 %	71 %	60 %	40 %
1TG31-5AA3	132	150	90 %	84 %	66 %	55 %	35 %
1TG31-8AA3	160	175	92 %	87 %	70 %	60 %	40 %
1TG32-2AA3	200	215	92 %	87 %	70 %	60 %	40 %
1TG32-6AA3	250	260	92 %	88 %	71 %	60 %	40 %
1TG33-3AA3	315	330	89 %	82 %	65 %	55 %	40 %
1TG34-1AA3	400	410	89 %	82 %	65 %	55 %	35 %
1TG34-7AA3	450	465	92 %	87 %	67 %	55 %	35 %
1TG35-8AA3	560	575	91 %	85 %	64 %	50 %	35 %
1TG37-4AA3	710	735	87 %	79 %	64 %	55 %	25 %
1TG38-1AA3	800	810	97 %	95 %	71 %	55 %	35 %
1TG38-8AA3	900	910	92 %	87 %	67 %	55 %	33 %
1TG41-0AA3	1000	1025	91 %	86 %	64 %	50 %	30 %
1TG41-3AA3	1200	1270	87 %	79 %	55 %	40 %	25 %

The following tables list the maximum achievable output frequency as a function of the pulse frequency.

Maximum output frequencies achieved by increasing the pulse frequency in Vector mode

Pulse frequency	Max. achievable output frequency
1.25 kHz	100 Hz
2 kHz	160 Hz
2.5 kHz	200 Hz
4 kHz	300 Hz

Maximum output frequencies achieved by increasing the pulse frequency in Servo mode

Pulse frequency	Max. achievable output frequency
2 kHz	300 Hz
4 kHz	300/550 Hz ¹⁾

¹⁾ Higher frequencies on request.

SINAMICS S120 Chassis Format Converter Units

Air-cooled units

Characteristic curves (continued)

Overload capability

SINAMICS S120 chassis units have an overload reserve, e.g. to handle breakaway torques. If larger surge loads occur, this must be taken into account in the configuration. For drives with overload requirements, the appropriate base load current must, therefore, be used as a basis for the required load.

The permissible overload levels are valid under the prerequisite that the drive units are operated with their base-load current before and after the overload condition based on a duty cycle duration of 300 s.

For temporary, periodic duty cycles with high variations of load within the duty cycle, the relevant sections of the SINAMICS Low Voltage Engineering Manual must be observed.

Power Modules and Motor Modules

The base load current for a low overload I_L is based on a duty cycle of 110 % for 60 s or 150 % for 10 s.

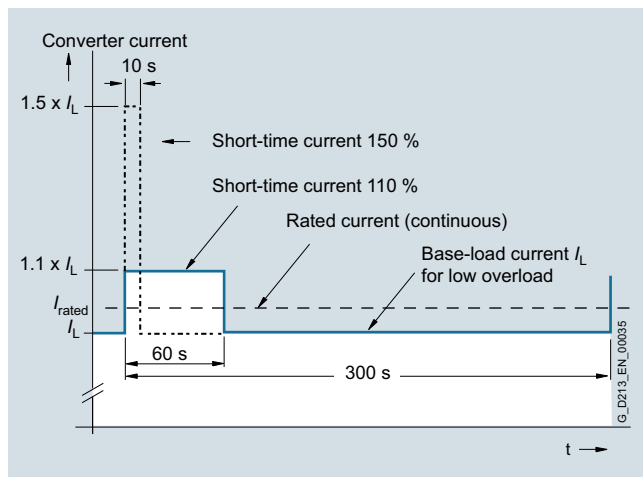

Low overload

The base load current for a high overload I_H is based on a duty cycle of 150 % for 60 s or 160 % for 10 s.

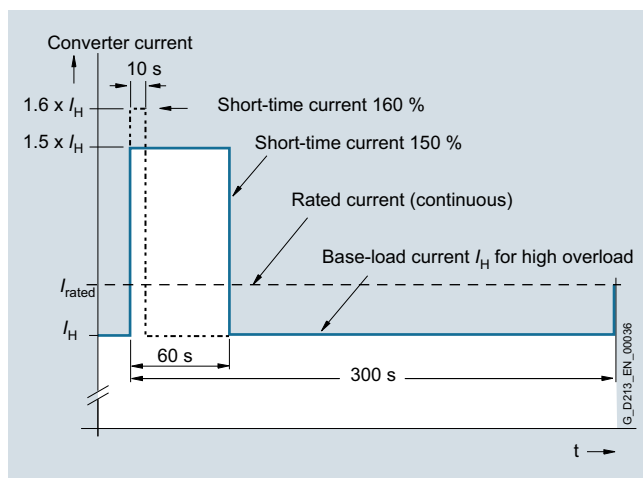

High overload

Line Modules

The base-load current for a high overload I_{HDC} is the basis for a duty cycle of 150 % for 60 s or $I_{max DC}$ for 5 s.

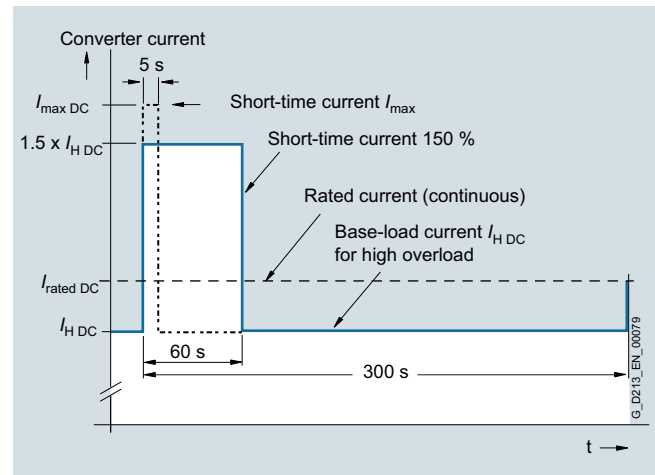

High overload

SINAMICS S120 Chassis Format Converter Units

Air-cooled units

Power Modules

Overview



The Power Module comprises a line rectifier, a DC link and an inverter to supply the motor.

Power Modules are designed for drives that are not capable of regenerating energy to the mains supply. Regenerative energy produced while braking is converted to heat using braking resistors.

Power Modules in the chassis format can be connected to grounded TN/TT systems and non-grounded IT systems.

Design

The Power Modules have the following interfaces as standard:

- 1 line supply connection
- 1 motor connection
- 1 connection for the 24 V DC electronics power supply
- 1 DC link connection (DCPA, DCNA) for connecting a Braking Module
- 1 DC link connection (DCPS, DCNS) for connecting a dv/dt filter
- 3 DRIVE-CLiQ sockets
- 1 temperature sensor input (KTY84-130, PTC or Pt100)
- 1 connection for Safe Brake Adapter
- 1 connection for Safety Integrated
- 2 PE connections

The Power Modules are controlled by the CU310-2 Control Unit that can be integrated into the Power Module.

The status of the Power Modules is indicated via three LEDs.

The scope of supply of the Power Modules includes:

- 1 DRIVE-CLiQ cable for connection to the Control Unit
- 1 24 V DC connecting cable for the power supply to the Control Unit
- 1 mounting plate for attaching the Control Unit
- 1 set of warning labels in 30 languages (BG, CN, CZ, DE, DK, EE, ES, FI, FR, GB, GR, HU, IE, IS, IT, JP, KR, LT, LV, MT, NL, NO, PL, PT, RO, RU, SE, SI, SK, TR)

Application in multi-axis systems

Power Modules in chassis format can also be connected directly via DRIVE-CLiQ to a separate CU320-2 or SIMOTION D4x5-2 Control Unit or Controller Extension CX32-2. The appropriate DRIVE-CLiQ cable for the required distance must be ordered as an additional accessory (see [System components](#), [Connection systems](#)).

Selection and ordering data

Type rating at 400 V	Rated output current	Power Module
kW	A	Article No.
Line voltage 380 ... 480 V 3 AC		
110	210	6SL3310-1TE32-1AA3
132	260	6SL3310-1TE32-6AA3
160	310	6SL3310-1TE33-1AA3
200	380	6SL3310-1TE33-8AA3
250	490	6SL3310-1TE35-0AA3

Description	Article No.
-------------	-------------

Accessories for re-ordering

Dust protection blanking plugs (50 units) For DRIVE-CLiQ port	6SL3066-4CA00-0AA0
--	---------------------------

For line and motor-side components, [Braking Modules](#) as well as [recommended line-side system components](#), see [System components](#).

SINAMICS S120 Chassis Format Converter Units

Air-cooled units

Power Modules

Integration

The Power Modules communicate with the higher-level control module via DRIVE-CLiQ. The Control Unit in this case could be a CU310-2, CU320-2 or a SIMOTION D Control Unit.

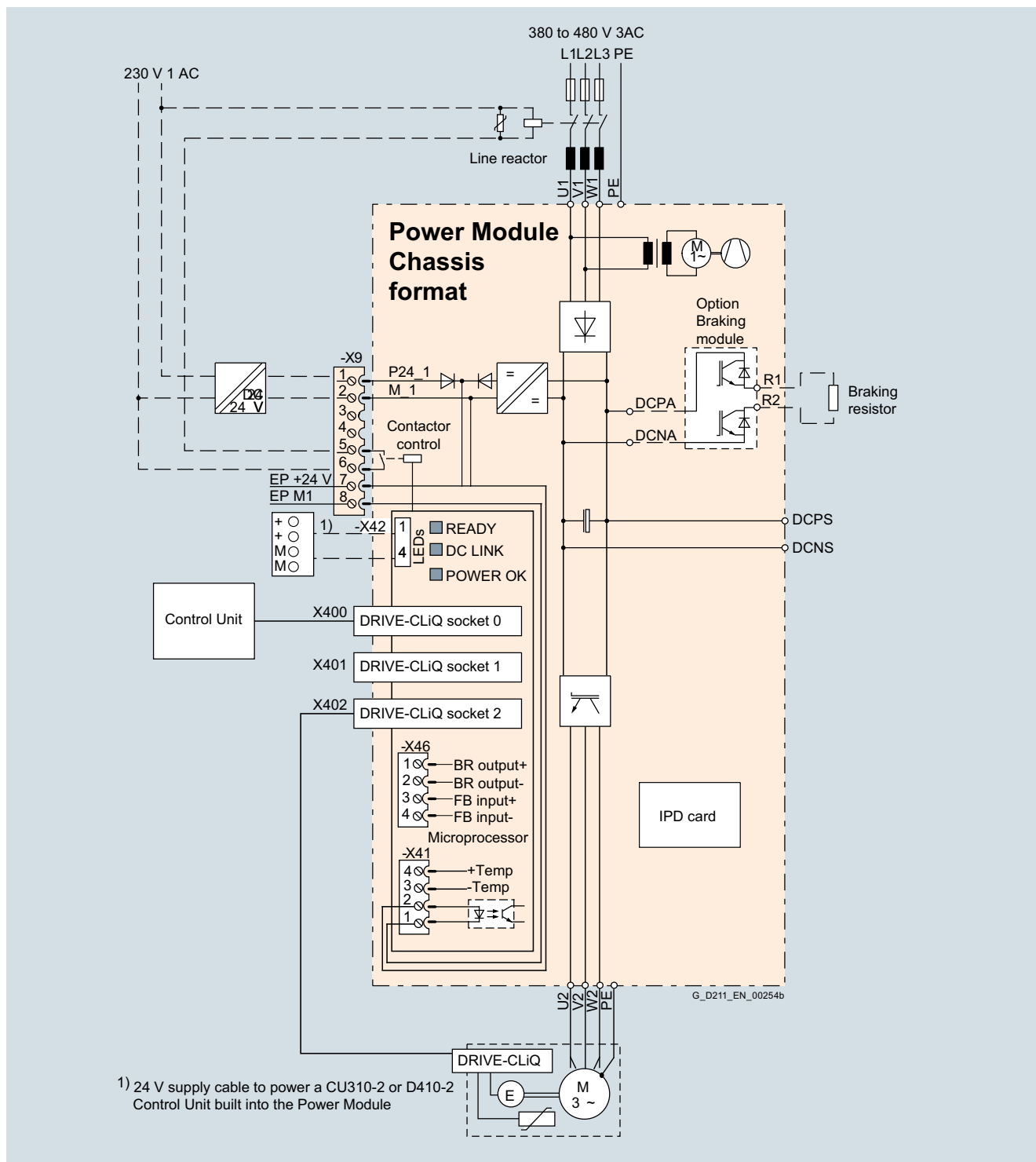

Connection example of a Power Module

Note:

The integrated 24 V power supply at connector X42 can have a maximum load of 2 A. When the Control Unit is supplied from the integrated power supply, the total load of the digital outputs must be carefully observed to ensure that the 2 A is not exceeded.

Technical specifications

General technical specifications

Electrical specifications	
Line connection voltage Up to 2000 m above sea level	380 ... 480 V 3 AC $\pm 10\%$ (-15 % < 1 min)
Line power factor for a 3 AC line supply voltage and output power	
• Basic fundamental ($\cos \varphi_1$)	>0.96
• Total (λ)	0.75 ... 0.93
DC link voltage, approx. ¹⁾	1.35 × line voltage
Output voltage, approx.	0.97 × U_{line}
Output frequency ²⁾	
• Control type Servo	0 ... 550 Hz
• Control type Vector	0 ... 550 Hz
• Control mode V/f	0 ... 550 Hz
Main contactor control	
• Terminal block -X9/5-6	240 V AC, max. 8 A 30 V DC, max. 1 A
Safety Integrated	Safety Integrity Level 2 (SIL2) acc. to IEC 61508, Performance Level d (PLd) acc. to EN ISO 13849-1 and Control Category 3 acc. to EN ISO 13849-1.

¹⁾ The DC link voltage is unregulated and load-dependent.
For additional information, please refer to the [SINAMICS Low Voltage Engineering Manual](#).

²⁾ Please note:

- The correlation between max. output frequency, pulse frequency and current derating. Higher output frequencies on request
- The correlation between the minimum output frequency and permissible output current (current derating). Information is provided in the [SINAMICS Low Voltage Engineering Manual](#).

SINAMICS S120 Chassis Format Converter Units

Air-cooled units

Power Modules

Technical specifications (continued)

Line voltage 380 ... 480 V 3 AC		Power Modules				
		6SL3310-1TE32-1AA3	6SL3310-1TE32-6AA3	6SL3310-1TE33-1AA3	6SL3310-1TE33-8AA3	6SL3310-1TE35-0AA3
Type rating						
• At I_L (50 Hz 400 V) ¹⁾	kW	110	132	160	200	250
• At I_H (50 Hz 400 V) ¹⁾	kW	90	110	132	160	200
• At I_L (60 Hz 460 V) ²⁾	hp	150	200	250	300	400
• At I_H (60 Hz 460 V) ²⁾	hp	150	200	200	250	350
Output current						
• Rated current $I_{rated O}$	A	210	260	310	380	490
• Base-load current I_L ³⁾	A	205	250	302	370	477
• Base-load current I_H ⁴⁾	A	178	233	277	340	438
• Maximum current $I_{max O}$	A	307	375	453	555	715
Input current						
• Rated input current $I_{rated I}$	A	229	284	338	395	509
• Maximum input current $I_{max I}$	A	335	410	495	606	781
Current demand						
• 24 V DC auxiliary power supply	A	0.8	0.8	0.9	0.9	0.9
Pulse frequency ⁵⁾						
• Rated frequency	kHz	2	2	2	2	2
• Pulse frequency, max.						
- Without current derating	kHz	2	2	2	2	2
- With current derating	kHz	8	8	8	8	8
Power loss, max. ⁶⁾						
• At 50 Hz 400 V	kW	2.46	3.27	4	4.54	5.78
• At 60 Hz 460 V	kW	2.54	3.36	4.07	4.67	5.96
Cooling air requirement		m ³ /s	0.17	0.23	0.36	0.36
Sound pressure level L_{pA} (1 m) at 50/60 Hz		dB	64/67	64/67	69/73	69/73
Line connection U1, V1, W1			M10 screw	M10 screw	M10 screw	M10 screw
• Conductor cross section, max. (IEC)	mm ²	2 × 185	2 × 185	2 × 240	2 × 240	2 × 240
Motor connection U2/T1, V2/T2, W2/T3			M10 screw	M10 screw	M10 screw	M10 screw
• Conductor cross section, max. (IEC)	mm ²	2 × 185	2 × 185	2 × 240	2 × 240	2 × 240
Cable length, max. ⁷⁾						
• Shielded	m	300	300	300	300	300
• Unshielded	m	450	450	450	450	450
PE1/GND connection			M10 screw	M10 screw	M10 screw	M10 screw
• Conductor cross section, max. (IEC)	mm ²	2 × 185	2 × 185	2 × 240	2 × 240	2 × 240
PE2/GND connection			M10 screw	M10 screw	M10 screw	M10 screw
• Conductor cross section, max. (IEC)	mm ²	2 × 185	2 × 185	2 × 240	2 × 240	2 × 240
Degree of protection			IP20	IP20	IP20	IP20
Dimensions						
• Width	mm	326	326	326	326	326
• Height	mm	1400	1400	1533	1533	1533
• Depth	mm	356 ⁸⁾	356 ⁸⁾	549	549	549
Weight, approx.		kg	104	104	162	162
Frame size			FX	FX	GX	GX
Minimum short-circuit current ⁹⁾		A	3000	3600	4400	8000

¹⁾ Rated output of a typical 6-pole standard induction motor based on I_L or I_H for 400 V 3 AC 50 Hz.

²⁾ Rated output of a typical 6-pole standard induction motor based on I_L or I_H for 460 V 3 AC 60 Hz.

³⁾ The base-load current I_L is based on a load cycle of 110 % for 60 s or 150 % for 10 s with a load cycle duration of 300 s.

⁴⁾ The base-load current I_H is based on a duty cycle of 150 % for 60 s or 160 % for 10 s with a duty cycle duration of 300 s.

⁵⁾ Information regarding the correlation between the pulse frequency and maximum output current/output frequency is provided in the SINAMICS Low Voltage Engineering Manual.

⁶⁾ The specified power loss represents the maximum value at 100% utilization. The value is lower under normal operating conditions.

⁷⁾ Longer cable lengths for specific configurations are available on request. For additional information, please refer to the SINAMICS Low Voltage Engineering Manual.

⁸⁾ Depth = 421 mm including front cover when CU310-2 Control Unit is installed.

⁹⁾ Current required for reliably triggering protective devices.

SINAMICS S120 Chassis Format Converter Units

Air-cooled units

Basic Line Modules

Overview



Basic Line Modules are available for applications in which no energy is returned to the supply or where the energy exchange between motor and generator axes takes place in the DC link. Basic Line Modules are designed for connection to grounded TN/TT and non-grounded IT supply systems.

The Basic Line Modules are available in different frame sizes. With frame sizes FB and GB, a fully controlled thyristor bridge is used to pre-charge the Basic Line Modules and connected Motor Modules. The thyristors normally operate with a trigger delay angle of 0°.

Basic Line Modules, frame size GD for 900 kW (400 V) or 1500 kW (690 V) include a diode bridge, and the DC link is pre-charged via a separate line-side pre-charging circuit.

A Braking Module of the appropriate frame size can be integrated into a Basic Line Module in order to permit, in conjunction with an external braking resistor, regenerative operation of the drive system (→ DC link components).

Design

The Basic Line Modules have the following interfaces as standard:

- 1 line supply connection
- 1 connection for the 24 V DC electronics power supply
- 1 DC link connection (DCP, DCN) for supplying the connected Motor Modules
- 1 DC link connection (DCPA, DCNA) for connecting a Braking Module
- 3 DRIVE-CLiQ sockets
- 1 temperature sensor input (KTY84-130 or PTC)
- 1 PE connection

The status of the Basic Line Modules is indicated via three LEDs.

The scope of supply of the Basic Line Modules includes:

- DRIVE-CLiQ cable to connect to a Control Unit
- DRIVE-CLiQ cable to connect the Control Unit to the first Motor Module
- 1 set of warning labels in 30 languages (BG, CN, CZ, DE, DK, EE, ES, FI, FR, GB, GR, HU, IE, IS, IT, JP, KR, LT, LV, MT, NL, NO, PL, PT, RO, RU, SE, SI, SK, TR)

Pre-charging circuit for the Basic Line Modules, frame size GD

Unlike Basic Line Modules in frame sizes FB and GB, a Basic Line Module in frame size GD requires a separate precharging circuit. The pre-charging circuit components must be ordered separately.

During startup, the pre-charging circuit ensures that the DC link capacitors of the Basic Line Module and the connected Motor Modules are pre-charged with current limiting. After pre-charging has been completed, the circuit breaker is closed and the pre-charging circuit bypassed; the Basic Line Module is then directly connected to the line supply.

The pre-charging circuit comprises a pre-charging contactor and pre-charging resistors; the circuit must be protected against overcurrent using suitable protection measures. To increase the permissible DC link capacitance, the pre-charging resistors can also be connected in parallel in each phase.

More information on the pre-charging circuit is to be found in the SINAMICS Low Voltage Engineering Manual.

For components for the pre-charging circuit and for recommended line-side system components, see System components.

Selection and ordering data

Rated power at 400 V or 690 V kW	Rated DC link current A	Basic Line Module Article No.
Line voltage 380 ... 480 V 3 AC		
200	420	6SL3330-1TE34-2AA3
250	530	6SL3330-1TE35-3AA3
400	820	6SL3330-1TE38-2AA3
560	1200	6SL3330-1TE41-2AA3
710	1500	6SL3330-1TE41-5AA3
900	1880	6SL3330-1TE41-8AA3
Line voltage 500 ... 690 V 3 AC		
250	300	6SL3330-1TG33-0AA3
355	430	6SL3330-1TG34-3AA3
560	680	6SL3330-1TG36-8AA3
900	1100	6SL3330-1TG41-1AA3
1100	1400	6SL3330-1TG41-4AA3
1500	1880	6SL3330-1TG41-8AA3

Description	Article No.
-------------	-------------

Accessories for re-ordering

Dust protection blanking plugs (50 units) For DRIVE-CLiQ port	6SL3066-4CA00-0AA0
--	---------------------------

For line-side components and recommended line-side system components, see System components.

SINAMICS S120 Chassis Format Converter Units

Air-cooled units

Basic Line Modules

Integration

The Basic Line Modules communicate with the higher-level control module via DRIVE-CLiQ. The control module in this case can be a CU320-2 or a SIMOTION D Control Unit. An external 24 V DC power supply is required to operate Basic Line Modules.

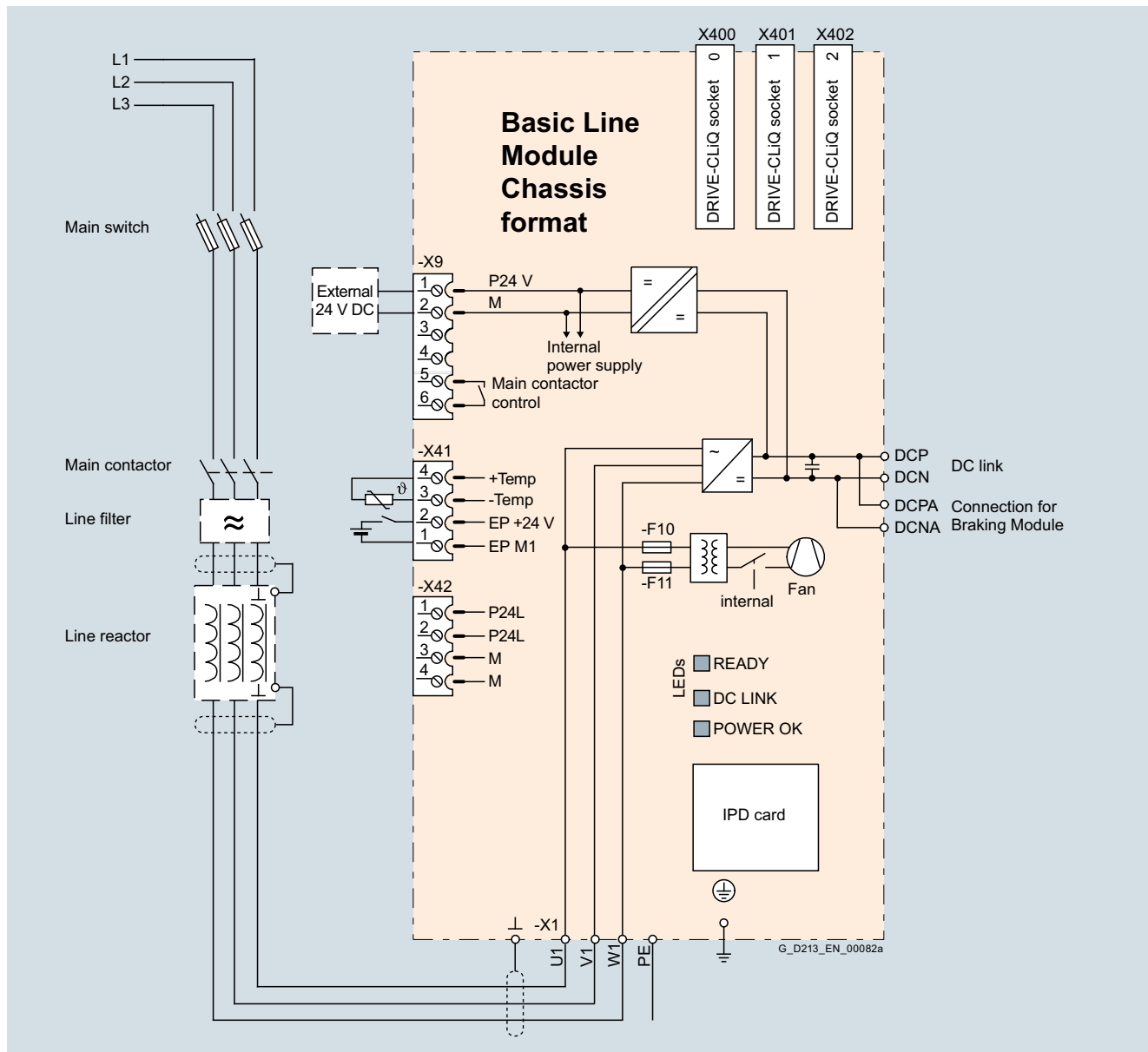

Connection example for Basic Line Module, frame sizes FB, GB

3

Integration (continued)

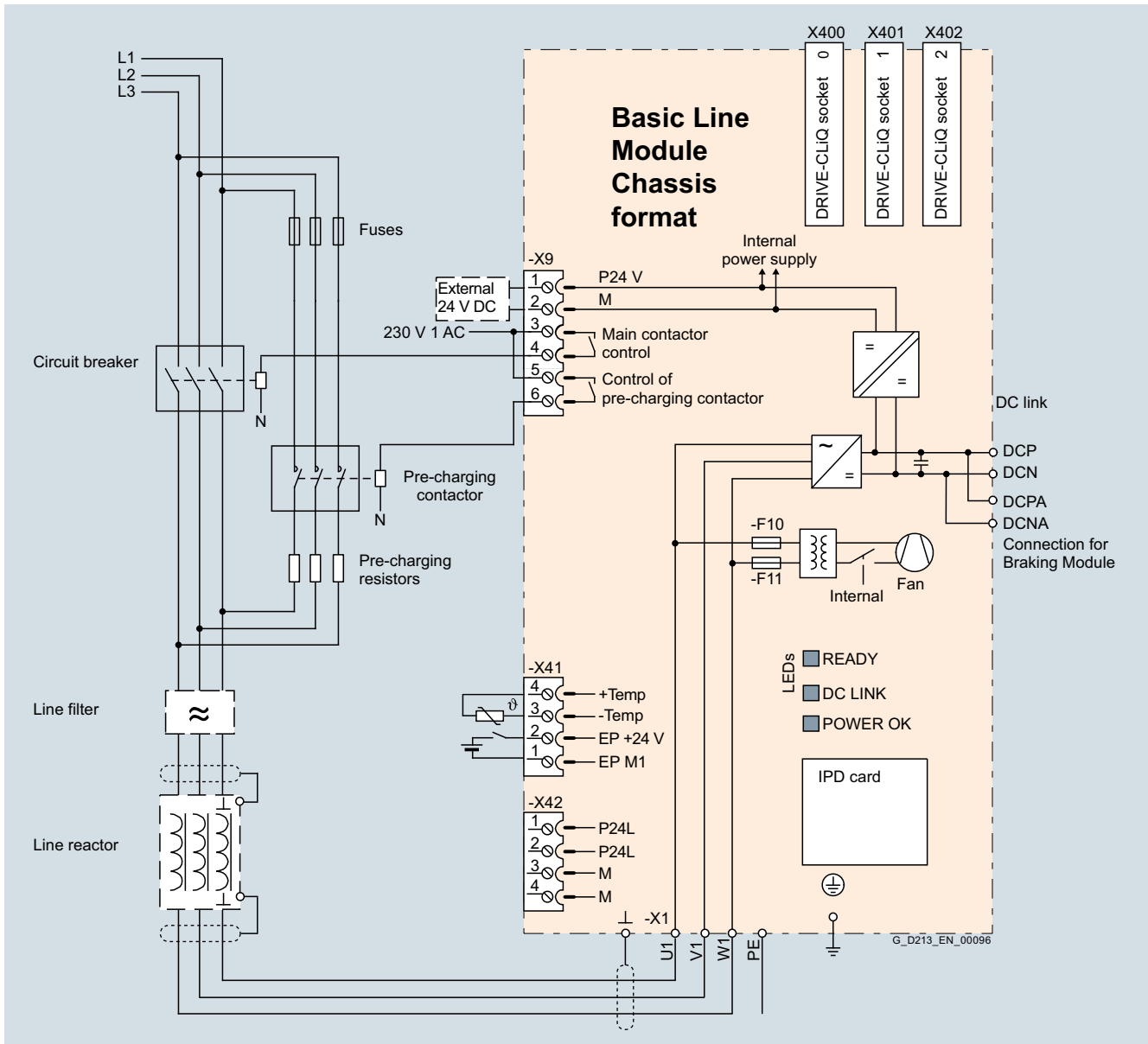

Connection example, Basic Line Module, frame size GD

Technical specifications

General technical specifications

Electrical specifications

Line power factor

at rated power

- Basic fundamental ($\cos \varphi_1$) >0.96
- Total (λ) 0.75 ... 0.93

Efficiency

>99 %

DC link voltage, approx. ¹⁾

1.35 × line voltage under partial load
1.32 × line voltage under full load

Main contactor control

- Terminal block -X9/5-6 240 V AC, max. 8 A
30 V DC, max. 1 A

¹⁾ The DC link voltage is unregulated and load-dependent.
For additional information, please refer to the
[SINAMICS Low Voltage Engineering Manual](#).

SINAMICS S120 Chassis Format Converter Units

Air-cooled units

Basic Line Modules

Technical specifications (continued)

Line voltage 380 ... 480 V 3 AC		Basic Line Modules					
		6SL3330-1TE34-2AA3	6SL3330-1TE35-3AA3	6SL3330-1TE38-2AA3	6SL3330-1TE41-2AA3	6SL3330-1TE41-5AA3	6SL3330-1TE41-8AA3
Rated power							
• At $I_{\text{rated DC}}$ (50 Hz 400 V)	kW	200	250	400	560	710	900
• At $I_{\text{H DC}}$ (50 Hz 400 V)	kW	160	200	315	450	560	705
• At $I_{\text{rated DC}}$ (60 Hz 460 V)	hp	305	385	615	860	1090	1390
• At $I_{\text{H DC}}$ (60 Hz 460 V)	hp	245	305	485	690	860	1090
DC link current							
• Rated current $I_{\text{rated DC}}$	A	420	530	820	1200	1500	1880
• Base-load current $I_{\text{H DC}}^{1)}$	A	328	413	640	936	1170	1467
• Maximum current $I_{\text{max DC}}$	A	630	795	1230	1800	2250	2820
Input current							
• Rated current $I_{\text{rated I}}$	A	365	460	710	1010	1265	1630
• Maximum current $I_{\text{max I}}$	A	547	690	1065	1515	1897	2380
• Max. pre-charging current (max. 3 s)	A	Internal	Internal	Internal	Internal	Internal	308
Current demand							
• 24 V DC auxiliary power supply	A	1.1	1.1	1.1	1.1	1.1	1.1
DC link capacitance							
• Basic Line Module	μF	7200	9600	14600	23200	29000	34800
• Drive line-up, max.	μF	57600	76800	116800	185600	232000	139200/278400 ²⁾
Power loss, max.³⁾							
• At 50 Hz 400 V	kW	1.9	2.1	3.2	4.6	5.5	6.9
• At 60 Hz 460 V	kW	1.9	2.1	3.2	4.6	5.5	6.9
Cooling air requirement		m^3/s	0.17	0.17	0.17	0.36	0.36
Sound pressure level L_{pA} (1 m) at 50/60 Hz		dB	66/68	66/68	66/68	71/73	71/73
Line connection U1, V1, W1			Flat connector for M10 screw	Flat connector for M10 screw	Flat connector for M10 screw	Flat connector for M12 screw	Flat connector for M12 screw
• Conductor cross section, max. (IEC)	mm^2	2 × 240	2 × 240	2 × 240	6 × 185	6 × 185	6 × 185
DC link connection DCP, DCN			M10 screw	M10 screw	M10 screw	3 × hole for M12	3 × hole for M12
• Conductor cross section, max. (IEC)	mm^2	2 × 240	2 × 240	2 × 240	6 × 185	6 × 185	6 × 185
PE/GND connection			2 × hole for M10	2 × hole for M10	2 × hole for M10	2 × hole for M12	2 × hole for M12
• Conductor cross section, max. (IEC)	mm^2	2 × 240	2 × 240	2 × 240	4 × 240	4 × 240	4 × 240
Cable length, max.⁴⁾							
• Shielded	m	2600	2600	2600	4000	4000	4800
• Unshielded	m	3900	3900	3900	6000	6000	7200
Degree of protection			IP00	IP00	IP00	IP00	IP00
Dimensions							
• Width	mm	310	310	310	310	310	310
• Height	mm	1164	1164	1164	1653	1653	1653
• Depth	mm	352	352	352	550	550	550
Weight, approx.		kg	96	96	96	214	214
Frame size			FB	FB	FB	GB	GD
Minimum short-circuit current⁵⁾		A	4400	5200	10000	12400	18400

¹⁾ The base-load current $I_{\text{H DC}}$ is the basis for a duty cycle of 150 % for 60 s or $I_{\text{max DC}}$ for 5 s with a duty cycle duration of 300 s.

²⁾ The first value applies for one precharging resistor for each phase, the second value for two precharging resistors connected in parallel for each phase.

³⁾ The specified power loss represents the maximum value at 100% utilization. The value is lower under normal operating conditions.

⁴⁾ Total of all motor cables and DC link. Longer cable lengths for specific configurations are available on request.

For additional information, please refer to the [SINAMICS Low Voltage Engineering Manual](#).

⁵⁾ Current required for reliably triggering protective devices.

SINAMICS S120 Chassis Format Converter Units

Air-cooled units

Basic Line Modules

Technical specifications (continued)

Line voltage 500 ... 690 V 3 AC		Basic Line Modules					
		6SL3330-1TG33-0AA3	6SL3330-1TG34-3AA3	6SL3330-1TG36-8AA3	6SL3330-1TG41-1AA3	6SL3330-1TG41-4AA3	6SL3330-1TG41-8AA3
Rated power							
• At $I_{\text{rated DC}}$ (50 Hz 690 V)	kW	250	355	560	900	1100	1500
• At $I_{\text{H DC}}$ (50 Hz 690 V)	kW	195	280	440	710	910	1220
• At $I_{\text{rated DC}}$ (50 Hz 500 V)	kW	175	250	390	635	810	1085
• At $I_{\text{H DC}}$ (50 Hz 500 V)	kW	165	235	365	595	755	1015
• At $I_{\text{rated DC}}$ (60 Hz 575 V)	hp	250	350	600	900	1250	1500
• At $I_{\text{H DC}}$ (60 Hz 575 V)	hp	200	300	450	800	1000	1250
DC link current							
• Rated current $I_{\text{rated DC}}$	A	300	430	680	1100	1400	1880
• Base-load current $I_{\text{H DC}}^{1)}$	A	234	335	530	858	1092	1467
• Maximum current $I_{\text{max DC}}$	A	450	645	1020	1650	2100	2820
Input current							
• Rated current $I_{\text{rated I}}$	A	260	375	575	925	1180	1580
• Maximum current $I_{\text{max I}}$	A	390	563	863	1388	1770	2370
• Max. pre-charging current (max. 3 s)	A	Internal	Internal	Internal	Internal	Internal	234
Current demand							
• 24 V DC auxiliary power supply	A	1.1	1.1	1.1	1.1	1.1	1.1
DC link capacitance							
• Basic Line Module	μF	3200	4800	7300	11600	15470	19500
• Drive line-up, max.	μF	25600	38400	58400	92800	123760	78000/156000 ²⁾
Power loss, max.³⁾							
• At 50 Hz 690 V	kW	1.5	2.1	3.0	5.4	5.8	7.3
• At 60 Hz 575 V	kW	1.5	2.1	3.0	5.4	5.8	7.3
Cooling air requirement		m^3/s	0.17	0.17	0.17	0.36	0.36
Sound pressure level L_{pA} (1 m) at 50/60 Hz		dB	66/68	66/68	66/68	71/73	71/73
Line connection U1, V1, W1			Flat connector for M10 screw	Flat connector for M10 screw	Flat connector for M10 screw	Flat connector for M12 screw	Flat connector for M12 screw
• Conductor cross section, max. (IEC)	mm^2	2 × 240	2 × 240	2 × 240	6 × 185	6 × 185	6 × 185
DC link connection DCP, DCN			M10 screw	M10 screw	M10 screw	3 × hole for M12	3 × hole for M12
• Conductor cross section, max. (IEC)	mm^2	2 × 240	2 × 240	2 × 240	6 × 185	6 × 185	6 × 185
PE/GND connection			2 × hole for M10	2 × hole for M10	2 × hole for M10	2 × hole for M12	2 × hole for M12
• Conductor cross section, max. (IEC)	mm^2	2 × 240	2 × 240	2 × 240	4 × 240	4 × 240	4 × 240
Cable length, max.⁴⁾							
• Shielded	m	1500	1500	1500	2250	2250	2750
• Unshielded	m	2250	2250	2250	3375	3375	4125
Degree of protection			IP00	IP00	IP00	IP00	IP00
Dimensions							
• Width	mm	310	310	310	310	310	310
• Height	mm	1164	1164	1164	1653	1653	1653
• Depth	mm	352	352	352	550	550	550
Weight, approx.		kg	96	96	96	214	214
Frame size			FB	FB	FB	GB	GD
Minimum short-circuit current⁵⁾		A	3000	4400	8000	10400	16000

¹⁾ The base-load current $I_{\text{H DC}}$ is the basis for a duty cycle of 150 % for 60 s or $I_{\text{max DC}}$ for 5 s with a duty cycle duration of 300 s.

²⁾ The first value applies for one pre-charging resistor for each phase, the second value for two precharging resistors connected in parallel for each phase.

³⁾ The specified power loss represents the maximum value at 100% utilization. The value is lower under normal operating conditions.

⁴⁾ Total of all motor cables and DC link. Longer cable lengths for specific configurations are available on request.

For additional information, please refer to the [SINAMICS Low Voltage Engineering Manual](#).

⁵⁾ Current required for reliably triggering protective devices.

SINAMICS S120 Chassis Format Converter Units

Air-cooled units

Smart Line Modules

Overview



Smart Line Modules are infeed/regenerative feedback units that supply power to connected Motor Modules. Furthermore, they are capable of feeding regenerative energy back into the grid. The infeed occurs over a diode jumper, while stable, line-commutated regenerative feedback takes place via IGBTs with 100 % continuous energy regeneration. The regenerative capability of the modules can be deactivated by means of parameterization.

Smart Line Modules are designed for connection to grounded TN/TT and non-grounded IT supply systems.

The DC link is pre-charged by means of integrated pre-charging resistors.

To operate the Smart Line Module, the associated line reactor or a suitable transformer is required.

Design

The Smart Line Modules have the following interfaces as standard:

- 1 line supply connection
- 1 connection for the 24 V DC electronics power supply
- 1 DC link connection (DCP, DCN) for supplying the connected Motor Modules
- 1 DC link connection (DCPA, DCNA) for connecting a Braking Module
- 3 DRIVE-CLiQ sockets
- 1 temperature sensor input (KTY84-130, PTC or Pt100)
- 1 PE/protective conductor connection (2 connections for sizes HX and JX)

The status of the Smart Line Modules is indicated via three LEDs.

The scope of supply of the Smart Line Modules includes:

- DRIVE-CLiQ cable to connect to a Control Unit
- DRIVE-CLiQ cable for connection between the Control Unit and first Motor Module (type dependent)
- 1 set of warning labels in 30 languages (BG, CN, CZ, DE, DK, EE, ES, FI, FR, GB, GR, HU, IE, IS, IT, JP, KR, LT, LV, MT, NL, NO, PL, PT, RO, RU, SE, SI, SK, TR)

Selection and ordering data

Rated power at 400 V or 690 V kW	Infeed/regenerative feedback current A	Smart Line Module Article No.
Line voltage 380 ... 480 V 3 AC		
250	463	6SL3330-6TE35-5AA3
355	614	6SL3330-6TE37-3AA3
500	883	6SL3330-6TE41-1AA3
630	1093	6SL3330-6TE41-3AA3
800	1430	6SL3330-6TE41-7AA3
Line voltage 500 ... 690 V 3 AC		
450	463	6SL3330-6TG35-5AA3
710	757	6SL3330-6TG38-8AA3
1000	1009	6SL3330-6TG41-2AA3
1400	1430	6SL3330-6TG41-7AA3
Description		Article No.
Accessories for re-ordering		
Dust protection blanking plugs (50 units) For DRIVE-CLiQ port		6SL3066-4CA00-0AA0

For line-side components, Braking Modules, and recommended system components, see [System components](#).

SINAMICS S120 Chassis Format Converter Units

Air-cooled units

Smart Line Modules

Integration

The Smart Line Modules communicate with the higher-level control module via DRIVE-CLiQ. The control module in this case can be a CU320-2 or a SIMOTION D Control Unit. An external 24 V DC power supply is required to operate the Smart Line Modules.

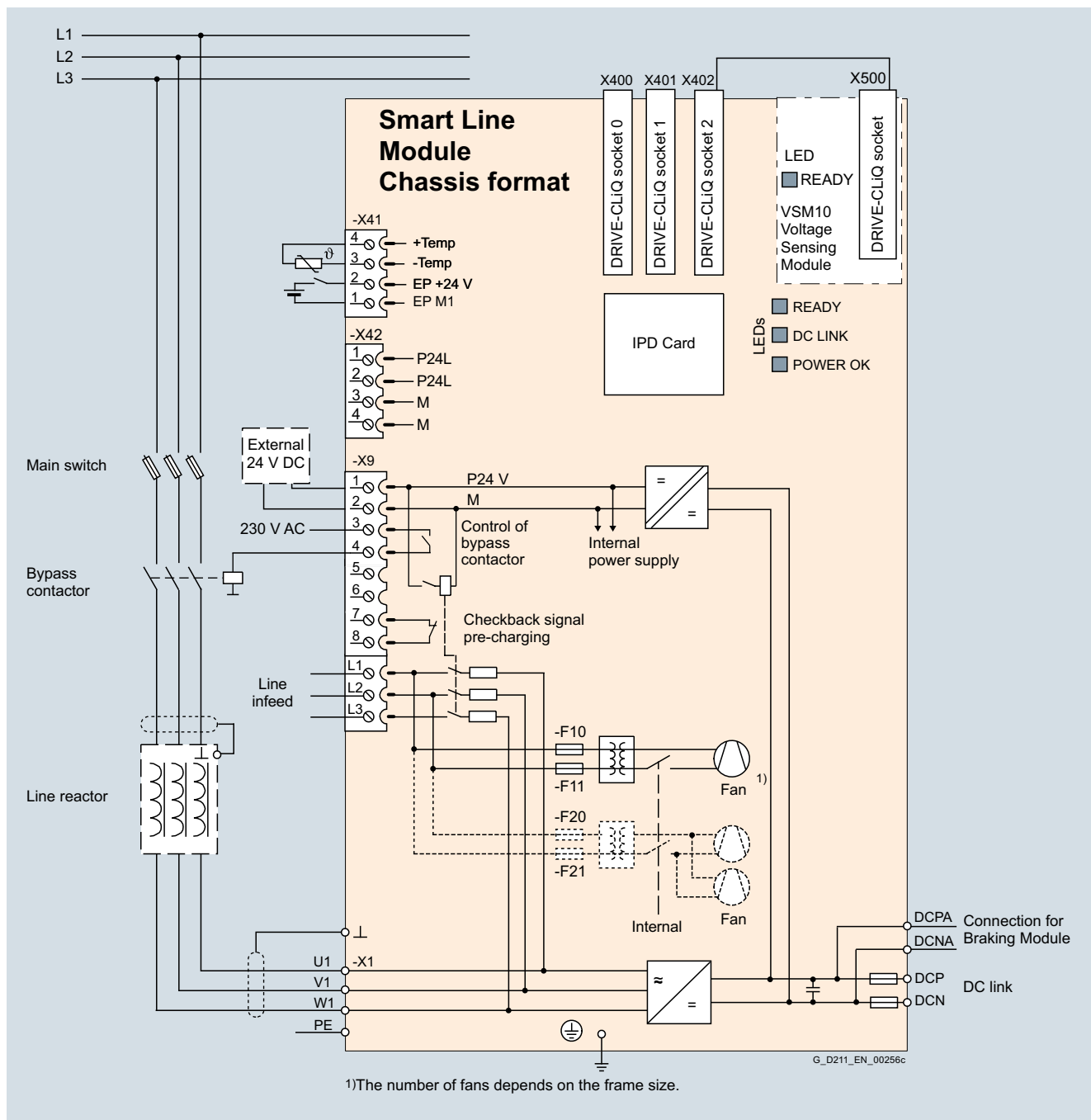

Connection example of a Smart Line Module

3

SINAMICS S120 Chassis Format Converter Units

Air-cooled units

Smart Line Modules

Technical specifications

General technical specifications

Electrical specifications

Line power factor at rated power

- | | |
|--|---------------|
| • Basic fundamental ($\cos \varphi_1$) | >0.96 |
| • Total (λ) | 0.75 ... 0.93 |

Efficiency	>98,5 %
-------------------	---------

DC link voltage, approx. ¹⁾	1.32 × line voltage under partial load 1.30 × line voltage under full load
---	---

Main contactor control

- | | |
|--------------------------|---|
| • Terminal block -X9/5-6 | 240 V AC, max. 8 A
30 V DC, max. 1 A |
|--------------------------|---|

3

¹⁾ The DC link voltage is unregulated and load-dependent.
For additional information, please refer to the
[SINAMICS Low Voltage Engineering Manual](#).

SINAMICS S120 Chassis Format Converter Units

Air-cooled units

Smart Line Modules

Technical specifications (continued)

Line voltage 380 ... 480 V 3 AC		Smart Line Modules				
		6SL3330-6TE35-5AA3	6SL3330-6TE37-3AA3	6SL3330-6TE41-1AA3	6SL3330-6TE41-3AA3	6SL3330-6TE41-7AA3
Rated power						
• At $I_{\text{rated DC}}$ (50 Hz 400 V)	kW	250	355	500	630	800
• At $I_{\text{H DC}}$ (50 Hz 400 V)	kW	235	315	450	555	730
• At $I_{\text{rated DC}}$ (60 Hz 460 V)	hp	385	545	770	970	1230
• At $I_{\text{H DC}}$ (60 Hz 460 V)	hp	360	485	695	855	1125
DC link current						
• Rated current $I_{\text{rated DC}}$	A	550	730	1050	1300	1700
• Base-load current $I_{\text{H DC}}^{1)}$	A	490	650	934	1157	1513
• Maximum current $I_{\text{max DC}}$	A	825	1095	1575	1950	2550
Infeed/regenerative feedback current						
• Rated current $I_{\text{rated I}}$	A	463	614	883	1093	1430
• Maximum current $I_{\text{max I}}$	A	694	921	1324	1639	2145
Current demand						
• 24 V DC auxiliary power supply	A	1.35	1.35	1.4	1.5	1.7
• 400 V AC	A	1.8	1.8	3.6	5.4	5.4
DC link capacitance						
• Smart Line Module	μF	8400	12000	16800	18900	28800
• Drive line-up, max.	μF	42000	60000	67200	75600	115200
Power loss, max. ²⁾						
• At 50 Hz 400 V	kW	3.7	4.7	7.1	11.0	11.5
• At 60 Hz 460 V	kW	3.7	4.7	7.1	11.0	11.5
Cooling air requirement		m^3/s	0.36	0.36	0.78	1.08
Sound pressure level L_{pA} (1 m) at 50/60 Hz		dB	69/73	69/73	70/73	70/73
Line connection U1, V1, W1			Flat connector for M10 screw	Flat connector for M10 screw	Flat connector for M12 screw	Flat connector for M12 screw
• Conductor cross section, max. (IEC)	mm^2	2 × 240	2 × 240	4 × 240	6 × 240	6 × 240
DC link connection DCP, DCN			M10 screw	M10 screw	4 × hole for M12	4 × hole for M12
• Conductor cross section, max. (IEC)	mm^2	2 × 240	2 × 240	Busbar	Busbar	Busbar
PE/GND connection			Hole for M10	Hole for M10	–	–
• Conductor cross section, max. (IEC)	mm^2	2 × 240	2 × 240	–	–	–
PE1/GND connection			–	–	M12 screw	M12 screw
• Conductor cross section, max. (IEC)	mm^2	–	–	240	240	240
PE2/GND connection			–	–	2 × M12 screw	2 × M12 screw
• Conductor cross section, max. (IEC)	mm^2	–	–	2 × 240	2 × 240	2 × 240
Cable length, max. ³⁾						
• Shielded	m	4000	4000	4800	4800	4800
• Unshielded	m	6000	6000	7200	7200	7200
Degree of protection			IP00	IP00	IP00	IP00
Dimensions						
• Width	mm	310	310	503	704	704
• Height	mm	1413	1413	1475	1480	1480
• Depth	mm	550	550	548	550	550
Weight, approx.		kg	150	150	294	458
Frame size			GX	GX	HX	JX
Minimum short-circuit current ⁴⁾		A	6200	9200	10400	16000

¹⁾ The base-load current $I_{\text{H DC}}$ is the basis for a duty cycle of 150 % for 60 s or $I_{\text{max DC}}$ for 5 s with a duty cycle duration of 300 s.

²⁾ The specified power loss represents the maximum value at 100% utilization. The value is lower under normal operating conditions.

³⁾ Total of all motor cables and DC link. Longer cable lengths for specific configurations are available on request.

For additional information, please refer to the [SINAMICS Low Voltage Engineering Manual](#).

⁴⁾ Current required for reliably triggering protective devices.

SINAMICS S120 Chassis Format Converter Units

Air-cooled units

Smart Line Modules

Technical specifications (continued)

Line voltage 500 ... 690 V 3 AC		Smart Line Modules			
		6SL3330-6TG35-5AA3	6SL3330-6TG38-8AA3	6SL3330-6TG41-2AA3	6SL3330-6TG41-7AA3
Rated power					
• At $I_{rated DC}$ (50 Hz 690 V)	kW	450	710	1000	1400
• At $I_{H DC}$ (50 Hz 690 V)	kW	405	665	885	1255
• At $I_{rated DC}$ (50 Hz 500 V)	kW	320	525	705	995
• At $I_{H DC}$ (50 Hz 500 V)	kW	295	480	640	910
• At $I_{rated DC}$ (60 Hz 575 V)	hp	500	790	1115	1465
• At $I_{H DC}$ (60 Hz 575 V)	hp	450	740	990	1400
DC link current					
• Rated current $I_{rated DC}$	A	550	900	1200	1700
• Base-load current $I_{H DC}$ ¹⁾	A	490	800	1068	1513
• Maximum current $I_{max DC}$	A	825	1350	1800	2550
Infeed/regenerative feedback current					
• Rated current $I_{rated I}$	A	463	757	1009	1430
• Maximum current $I_{max I}$	A	694	1135	1513	2145
Current demand					
• 24 V DC auxiliary power supply	A	1.35	1.4	1.5	1.7
• 500 V AC	A	1.3	2.9	4.3	4.3
• 690 V AC	A	0.94	2.1	3.1	3.1
DC link capacitance					
• Smart Line Module	μF	5600	7400	11100	14400
• Drive line-up, max.	μF	28000	29600	44400	57600
Power loss, max. ²⁾					
• At 50 Hz 690 V	kW	4.3	6.5	12.0	13.8
• At 60 Hz 575 V	kW	4.3	6.5	12.0	13.8
Cooling air requirement					
	m ³ /s	0.36	0.78	1.08	1.08
Sound pressure level L_{pA} (1 m) at 50/60 Hz					
	dB	69/73	70/73	70/73	70/73
Line connection U1, V1, W1					
• Conductor cross section, max. (IEC)	mm ²	Flat connector for M10 screw 2 × 240	Flat connector for M12 screw 4 × 240	Flat connector for M12 screw 6 × 240	Flat connector for M12 screw 6 × 240
DC link connection DCP, DCN					
• Conductor cross section, max. (IEC)	mm ²	M10 screw 2 × 240	4 × hole for M12 Busbar	4 × hole for M12 Busbar	4 × hole for M12 Busbar
PE connection					
• Conductor cross section, max. (IEC)	mm ²	Hole for M10 2 × 240	–	–	–
PE1/GND connection					
• Conductor cross section, max. (IEC)	mm ²	–	M12 screw 240	M12 screw 240	M12 screw 240
PE2/GND connection					
• Conductor cross section, max. (IEC)	mm ²	–	2 × M12 screw 2 × 240	2 × M12 screw 2 × 240	2 × M12 screw 2 × 240
Cable length, max. ³⁾					
• Shielded	m	2250	2750	2750	2750
• Unshielded	m	3375	4125	4125	4125
Degree of protection					
		IP00	IP00	IP00	IP00
Dimensions					
• Width	mm	310	503	704	704
• Height	mm	1413	1475	1480	1480
• Depth	mm	550	548	550	550
Weight, approx.					
	kg	150	294	458	458
Frame size					
		GX	HX	JX	JX
Minimum short-circuit current ⁴⁾					
	A	6200	10500	12400	21000

¹⁾ The base-load current $I_{H DC}$ is the basis for a duty cycle of 150 % for 60 s or $I_{max DC}$ for 5 s with a duty cycle duration of 300 s.

²⁾ The specified power loss represents the maximum value at 100% utilization. The value is lower under normal operating conditions.

³⁾ Total of all motor cables and DC link. Longer cable lengths for specific configurations are available on request.
For additional information, please refer to the [SINAMICS Low Voltage Engineering Manual](#).

⁴⁾ Current required for reliably triggering protective devices.

SINAMICS S120 Chassis Format Converter Units

Air-cooled units

Active Line Modules

Overview



The self-commutated infeed/regenerative feedback units with IGBTs generate a regulated DC link voltage. This means that the connected Motor Modules are decoupled from the line voltage. Line voltage fluctuations within the permissible supply tolerances have no effect on the motor voltage.

If required, the Active Line Modules can also provide reactive power compensation.

Active Line Modules are designed for connection to grounded TN/TT and non-grounded IT supply systems.

Active Line Modules are always operated together with the associated Active Interface Modules. These include the necessary pre-charging circuit as well as a Clean Power Filter.

Design

The Active Line Modules have the following interfaces as standard:

- 1 line supply connection
- 1 connection for the 24 V DC electronics power supply
- 1 DC link connection (DCP, DCN) for supplying the connected Motor Modules
- 1 DC link connection (DCPA, DCNA) for connecting a Braking Module
- 3 DRIVE-CLiQ sockets
- 1 temperature sensor input (KTY84-130, PTC or Pt100)
- 2 PE connections

The status of the Active Line Modules is indicated via three LEDs.

The scope of supply of the Active Line Modules includes:

- DRIVE-CLiQ cable to connect to a Control Unit
- DRIVE-CLiQ cable to connect the Control Unit to the first Motor Module
- 1 set of warning labels in 30 languages (BG, CN, CZ, DE, DK, EE, ES, FI, FR, GB, GR, HU, IE, IS, IT, JP, KR, LT, LV, MT, NL, NO, PL, PT, RO, RU, SE, SI, SK, TR)

Selection and ordering data

Rated power at 400 V or 690 V kW	Rated infeed/ regenerative feedback current A	Active Line Module Article No.
Line voltage 380 ... 480 V 3 AC		
132	210	6SL3330-7TE32-1AA3
160	260	6SL3330-7TE32-6AA3
235	380	6SL3330-7TE33-8AA3
300	490	6SL3330-7TE35-0AA3
380	605	6SL3330-7TE36-1AA3
450	745	6SL3330-7TE37-5AA3
500	840	6SL3330-7TE38-4AA3
630	985	6SL3330-7TE41-0AA3
800	1260	6SL3330-7TE41-2AA3
900	1405	6SL3330-7TE41-4AA3
Line voltage 500 ... 690 V 3 AC		
630	575	6SL3330-7TG35-8AA3
800	735	6SL3330-7TG37-4AA3
1100	1025	6SL3330-7TG41-0AA3
1400	1270	6SL3330-7TG41-3AA3

Description	Article No.
-------------	-------------

Accessories for re-ordering

Dust protection blanking plugs (50 units) For DRIVE-CLiQ port	6SL3066-4CA00-0AA0
--	---------------------------

For line-side components, Braking Modules, and recommended system components, see System components.

SINAMICS S120 Chassis Format Converter Units

Air-cooled units

Active Line Modules

Integration

The Active Line Modules communicate with the higher-level control module via DRIVE-CLiQ. The control module in this case can be a CU320-2 or a SIMOTION D Control Unit. An external 24 V DC power supply is required to operate the Active Line Modules.

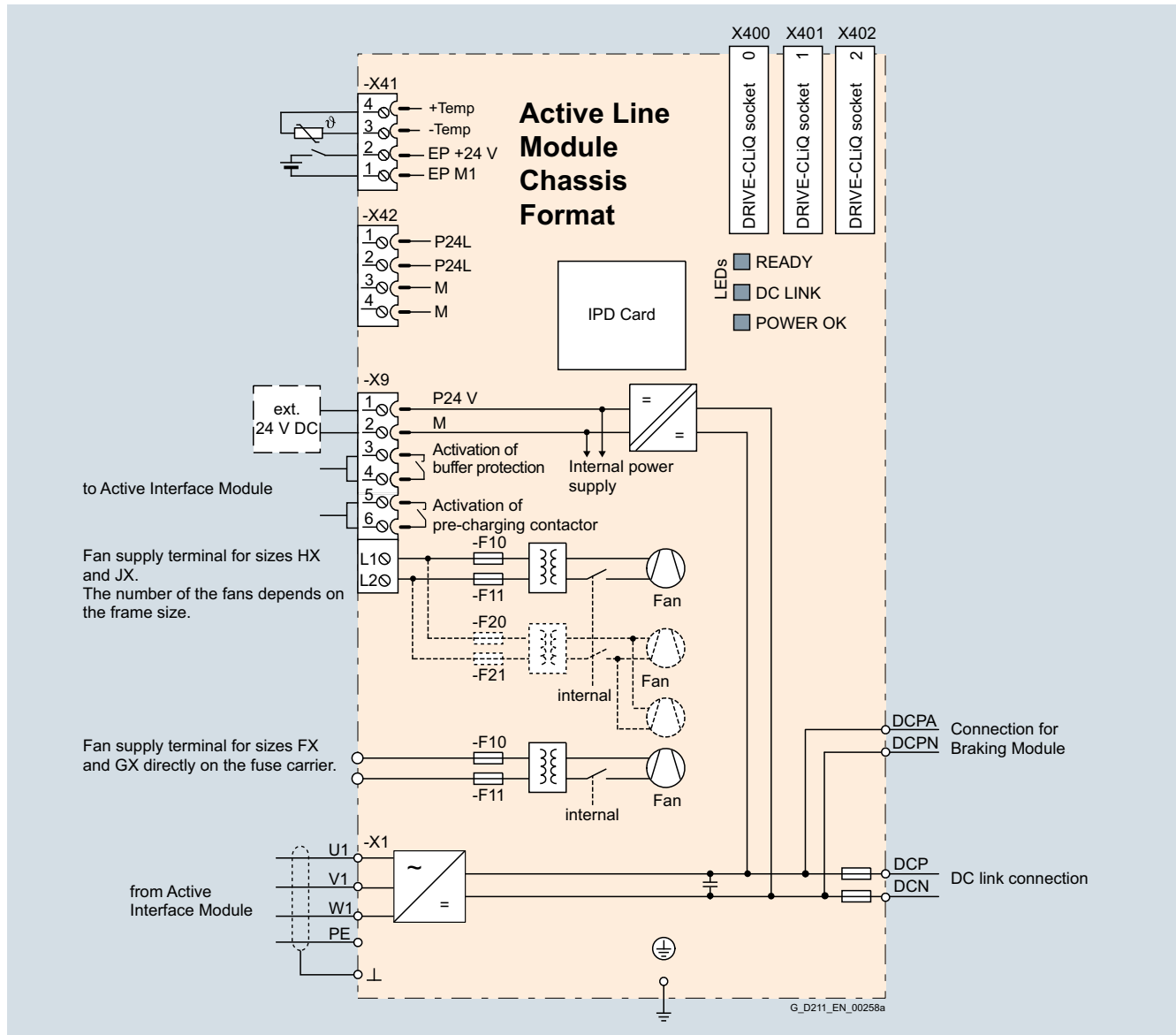

Connection example of an Active Line Module

Technical specifications

General technical specifications

Electrical specifications

Line power factor

- Basic fundamental ($\cos \varphi_1$) 1 (factory setting), can be altered by inputting a reactive current setpoint
- Total (λ) 1 (factory setting)

Efficiency >97.5 % (including Active Interface Module)

DC link voltage The DC link voltage is regulated and can be adjusted as a voltage decoupled from the line voltage. Factory setting of the DC link voltage: $1.5 \times$ line voltage

Radio interference suppression, standard Category C3 according to EN 61800-3 (with Active Interface Module)

SINAMICS S120 Chassis Format Converter Units

Air-cooled units

Active Line Modules

Technical specifications (continued)

Line voltage 380 ... 480 V 3 AC		Active Line Modules					
		6SL3330-7TE32-1AA3	6SL3330-7TE32-6AA3	6SL3330-7TE33-8AA3	6SL3330-7TE35-0AA3	6SL3330-7TE36-1AA3	
Rated power							
• At $I_{\text{rated DC}}$ (50 Hz 400 V)	kW	132	160	235	300	380	
• At $I_{\text{H DC}}$ (50 Hz 400 V)	kW	115	145	210	270	335	
• At $I_{\text{rated DC}}$ (60 Hz 460 V)	hp	200	250	400	500	600	
• At $I_{\text{H DC}}$ (60 Hz 460 V)	hp	150	200	300	400	500	
DC link current							
• Rated current $I_{\text{rated DC}}$	A	235	291	425	549	678	
• Base-load current $I_{\text{H DC}}^{1)}$	A	209	259	378	489	603	
• Maximum current $I_{\text{max DC}}$	A	352	436	637	823	1017	
Infeed/regenerative feedback current							
• Rated current $I_{\text{rated I}}$	A	210	260	380	490	605	
• Maximum current $I_{\text{max I}}$	A	315	390	570	735	907	
Current demand							
• 24 V DC auxiliary power supply	A	1.1	1.1	1.35	1.35	1.4	
• 400 V AC	A	0.63	1.13	1.8	1.8	3.6	
DC link capacitance							
• Active Line Module	μF	4200	5200	7800	9600	12600	
• Drive line-up, max.	μF	41600	41600	76800	76800	134400	
Power loss, max. ²⁾							
• At 50 Hz 400 V	kW	2.2	2.7	3.9	4.8	6.2	
• At 60 Hz 460 V	kW	2.3	2.9	4.2	5.1	6.6	
Cooling air requirement		m^3/s	0.17	0.23	0.36	0.36	0.78
Sound pressure level L_{pA} ³⁾ (1 m) at 50/60 Hz		dB	64/67	64/67	69/73	69/73	70/73
Line connection U1, V1, W1			Flat connector for M10 screw	Flat connector for M10 screw	Flat connector for M10 screw	Flat connector for M10 screw	Flat connector for M12 screw
• Conductor cross section, max. (IEC)	mm^2	2 × 185	2 × 185	2 × 240	2 × 240	4 × 240	
DC link connection DCP, DCN			M10 screw	M10 screw	M10 screw	M10 screw	4 × hole for M12
• Conductor cross section, max. (IEC)	mm^2	2 × 185	2 × 185	2 × 240	2 × 240	Busbar	
PE1/GND connection			M10 screw	M10 screw	M10 screw	M10 screw	M12 screw
• Conductor cross section, max. (IEC)	mm^2	2 × 185	2 × 185	2 × 240	2 × 240	240	
PE2/GND connection			M10 screw	M10 screw	M10 screw	M10 screw	2 × M12 screw
• Conductor cross section, max. (IEC)	mm^2	2 × 185	2 × 185	2 × 240	2 × 240	2 × 240	
Cable length, max. ⁴⁾							
• Shielded	m	2700	2700	2700	2700	3900	
• Unshielded	m	4050	4050	4050	4050	5850	
Degree of protection			IP20	IP20	IP20	IP20	IP00
Dimensions							
• Width	mm	326	326	326	326	503	
• Height	mm	1400	1400	1533	1533	1475	
• Depth	mm	356	356	545	545	540	
Weight, approx.		kg	95	95	136	136	290
Frame size			FX	FX	GX	GX	HX
Minimum short-circuit current ⁵⁾		A	6200	10500	10500	8000	9200

¹⁾ The base-load current $I_{\text{H DC}}$ is the basis for a duty cycle of 150 % for 60 s or $I_{\text{max DC}}$ for 5 s with a duty cycle duration of 300 s.

²⁾ The specified power loss represents the maximum value at 100% utilization. The value is lower under normal operating conditions.

³⁾ Total sound pressure level of Active Interface Module and Active Line Module.

⁴⁾ Total of all motor cables and DC link. Longer cable lengths for specific configurations are available on request. For additional information, please refer to the SINAMICS Low Voltage Engineering Manual.

⁵⁾ Current required for reliably triggering protective devices.

SINAMICS S120 Chassis Format Converter Units

Air-cooled units

Active Line Modules

Technical specifications (continued)

Line voltage 380 ... 480 V 3 AC		Active Line Modules				
		6SL3330-7TE37-5AA3	6SL3330-7TE38-4AA3	6SL3330-7TE41-0AA3	6SL3330-7TE41-2AA3	6SL3330-7TE41-4AA3
Rated power						
• At $I_{\text{rated DC}}$ (50 Hz 400 V)	kW	450	500	630	800	900
• At $I_{\text{H DC}}$ (50 Hz 400 V)	kW	400	465	545	690	780
• At $I_{\text{rated DC}}$ (60 Hz 460 V)	hp	600	700	900	1000	1250
• At $I_{\text{H DC}}$ (60 Hz 460 V)	hp	600	700	800	900	1000
DC link current						
• Rated current $I_{\text{rated DC}}$	A	835	940	1103	1412	1574
• Base-load current $I_{\text{H DC}}^{1)}$	A	700	837	982	1255	1401
• Maximum current $I_{\text{max DC}}$	A	1252	1410	1654	2120	2361
Infeed/regenerative feedback current						
• Rated current $I_{\text{rated I}}$	A	745	840	985	1260	1405
• Maximum current $I_{\text{max I}}$	A	1117	1260	1477	1890	2107
Current demand						
• 24 V DC auxiliary power supply	A	1.4	1.4	1.5	1.7	1.7
• 400 V AC	A	3.6	3.6	5.4	5.4	5.4
DC link capacitance						
• Active Line Module	μF	15600	16800	18900	26100	28800
• Drive line-up, max.	μF	134400	134400	230400	230400	230400
Power loss, max. ²⁾						
• At 50 Hz 400 V	kW	7.3	7.7	10.1	12.1	13.3
• At 60 Hz 460 V	kW	7.7	8.2	10.8	13.0	14.2
Cooling air requirement		m^3/s	0.78	0.78	1.08	1.08
Sound pressure level $L_{\text{pA}}^{3)}$ (1 m) at 50/60 Hz		dB	70/73	70/73	71/73	71/73
Line connection U1, V1, W1			Flat connector for M12 screw	Flat connector for M12 screw	Flat connector for M12 screw	Flat connector for M12 screw
• Conductor cross section, max. (IEC)	mm^2	4 × 240	4 × 240	6 × 240	6 × 240	6 × 240
DC link connection DCP, DCN			4 × hole for M12	4 × hole for M12	4 × hole for M12	4 × hole for M12
• Conductor cross section, max. (IEC)	mm^2	Busbar	Busbar	Busbar	Busbar	Busbar
PE1/GND connection			M12 screw	M12 screw	M12 screw	M12 screw
• Conductor cross section, max. (IEC)	mm^2	240	240	240	240	240
PE2/GND connection			2 × M12 screw	2 × M12 screw	3 × M12 screw	3 × M12 screw
• Conductor cross section, max. (IEC)	mm^2	2 × 240	2 × 240	3 × 240	3 × 240	3 × 240
Cable length, max. ⁴⁾						
• Shielded	m	3900	3900	3900	3900	3900
• Unshielded	m	5850	5850	5850	5850	5850
Degree of protection			IP00	IP00	IP00	IP00
Dimensions						
• Width	mm	503	503	704	704	704
• Height	mm	1475	1475	1480	1480	1480
• Depth	mm	540	540	550	550	550
Weight, approx.		kg	290	290	450	450
Frame size			HX	HX	JX	JX
Minimum short-circuit current ⁵⁾		A	8800	10400	16000	21000

¹⁾ The base-load current $I_{\text{H DC}}$ is the basis for a duty cycle of 150 % for 60 s or $I_{\text{max DC}}$ for 5 s with a duty cycle duration of 300 s.

²⁾ The specified power loss represents the maximum value at 100% utilization. The value is lower under normal operating conditions.

³⁾ Total sound pressure level of Active Interface Module and Active Line Module.

⁴⁾ Total of all motor cables and DC link. Longer cable lengths for specific configurations are available on request. For additional information, please refer to the SINAMICS Low Voltage Engineering Manual.

⁵⁾ Current required for reliably triggering protective devices.

SINAMICS S120 Chassis Format Converter Units

Air-cooled units

Active Line Modules

Technical specifications (continued)

Line voltage 500 ... 690 V 3 AC		Active Line Modules			
		6SL3330-7TG35-8AA3	6SL3330-7TG37-4AA3	6SL3330-7TG41-0AA3	6SL3330-7TG41-3AA3
Rated power					
• At $I_{rated\ DC}$ (50 Hz 690 V)	kW	630	800	1100	1400
• At $I_{H\ DC}$ (50 Hz 690 V)	kW	620	705	980	1215
• At $I_{rated\ DC}$ (50 Hz 500 V)	kW	447	560	780	965
• At $I_{H\ DC}$ (50 Hz 500 V)	kW	450	510	710	880
• At $I_{rated\ DC}$ (60 Hz 575 V)	hp	675	900	1250	1500
• At $I_{H\ DC}$ (60 Hz 575 V)	hp	506	600	1000	1250
DC link current					
• Rated current $I_{rated\ DC}$	A	644	823	1148	1422
• Base-load current $I_{H\ DC}^{1)}$	A	573	732	1022	1266
• Maximum current $I_{max\ DC}$	A	966	1234	1722	2133
Infeed/regenerative feedback current					
• Rated current $I_{rated\ I}$	A	575	735	1025	1270
• Maximum current $I_{max\ I}$	A	862	1102	1537	1905
Current demand					
• 24 V DC auxiliary power supply	A	1.4	1.5	1.7	1.7
• 500 V AC	A	3.0	4.4	4.4	4.4
• 690 V AC	A	2.1	3.1	3.1	3.1
DC link capacitance					
• Active Line Module	μF	7400	11100	14400	19200
• Drive line-up, max.	μF	59200	153600	153600	153600
Power loss, max. ²⁾					
• At 50 Hz 690 V	kW	6.8	10.2	13.6	16.5
• At 60 Hz 575 V	kW	6.2	9.6	12.9	15.3
Cooling air requirement		m ³ /s	0.78	1.08	1.08
Sound pressure level L_{pA} ³⁾ (1 m) at 50/60 Hz		dB	70/73	71/73	71/73
Line connection U1, V1, W1			Flat connector for M12 screw	Flat connector for M12 screw	Flat connector for M12 screw
• Conductor cross section, max. (IEC)	mm ²	4 × 240	6 × 240	6 × 240	6 × 240
DC link connection DCP, DCN			4 × hole for M12	4 × hole for M12	4 × hole for M12
• Conductor cross section, max. (IEC)	mm ²	Busbar	Busbar	Busbar	Busbar
PE1/GND connection			M12 screw	M12 screw	M12 screw
• Conductor cross section, max. (IEC)	mm ²	240	240	240	240
PE2/GND connection			2 × M12 screw	3 × M12 screw	3 × M12 screw
• Conductor cross section, max. (IEC)	mm ²	2 × 240	3 × 240	3 × 240	3 × 240
Cable length, max. ⁴⁾					
• Shielded	m	2250	2250	2250	2250
• Unshielded	m	3375	3375	3375	3375
Degree of protection			IP00	IP00	IP00
Dimensions					
• Width	mm	503	704	704	704
• Height	mm	1475	1480	1480	1480
• Depth	mm	540	550	550	550
Weight, approx.		kg	290	450	450
Frame size			HX	JX	JX
Minimum short-circuit current ⁵⁾		A	8400	10500	16000

¹⁾ The base-load current $I_{H\ DC}$ is the basis for a duty cycle of 150 % for 60 s or $I_{max\ DC}$ for 5 s with a duty cycle duration of 300 s.

²⁾ The specified power loss represents the maximum value at 100% utilization. The value is lower under normal operating conditions.

³⁾ Total sound pressure level of Active Interface Module and Active Line Module.

⁴⁾ Total of all motor cables and DC link. Longer cable lengths for specific configurations are available on request. For additional information, please refer to the SINAMICS Low Voltage Engineering Manual.

⁵⁾ Current required for reliably triggering protective devices.

SINAMICS S120 Chassis Format Converter Units

Air-cooled units

Active Interface Modules

Overview



Active Interface Modules are used in conjunction with Active Line Modules. Active Interface Modules contain a Clean Power Filter with basic RI suppression, the pre-charging circuit for the Active Line Module, the line voltage sensing circuit and monitoring sensors. The bypass contactor is an integral component in types FI and GI. This ensures a highly compact design. The bypass contactor must be provided separately for frame sizes HI and JI.

Line harmonics are largely suppressed by the Clean Power Filter.

Design

Active Interface Modules have the following interfaces as standard:

- 1 line supply connection
- 1 load connection
- 1 connection for the 24 V DC electronics power supply
- 1 connection for the external 230 V AC supply (fan power supply)
- 1 DRIVE-CLiQ socket (on VSM10 Voltage Sensing Module)
- 1 connection for pre-charging circuit, frame sizes HI and JI
- 1 PE connection

The scope of supply of the Active Interface Modules includes:

- DRIVE-CLiQ cable for the connection between Active Interface Module and Active Line Module
- 1 set of warning labels in 30 languages (BG, CN, CZ, DE, DK, EE, ES, FI, FR, GB, GR, HU, IE, IS, IT, JP, KR, LT, LV, MT, NL, NO, PL, PT, RO, RU, SE, SI, SK, TR)

Selection and ordering data

Suitable for Active Line Module chassis format, air-cooled	Rated power of the Active Line Modules at 400 V or 690 V kW	Active Interface Module
		Article No.
Line voltage 380 ... 480 V 3 AC		
6SL3330-7TE32-1AA3	132	6SL3300-7TE32-6AA0
6SL3330-7TE32-6AA3	160	6SL3300-7TE32-6AA0
6SL3330-7TE33-8AA3	235	6SL3300-7TE33-8AA0
6SL3330-7TE35-0AA3	300	6SL3300-7TE35-0AA0
6SL3330-7TE36-1AA3	380	6SL3300-7TE36-4AA0
6SL3330-7TE37-5AA3	450	6SL3300-7TE36-4AA0
6SL3330-7TE38-4AA3	500	6SL3300-7TE36-4AA0
6SL3330-7TE41-0AA3	630	6SL3300-7TE41-4AA0
6SL3330-7TE41-2AA3	800	6SL3300-7TE41-4AA0
6SL3330-7TE41-4AA3	900	6SL3300-7TE41-4AA0
Line voltage 500 ... 690 V 3 AC		
6SL3330-7TG35-8AA3	630	6SL3300-7TG35-8AA0
6SL3330-7TG37-4AA3	800	6SL3300-7TG37-4AA0
6SL3330-7TG41-0AA3	1100	6SL3300-7TG41-3AA0
6SL3330-7TG41-3AA3	1400	6SL3300-7TG41-3AA0

SINAMICS S120 Chassis Format Converter Units

Air-cooled units

Active Interface Modules

Integration

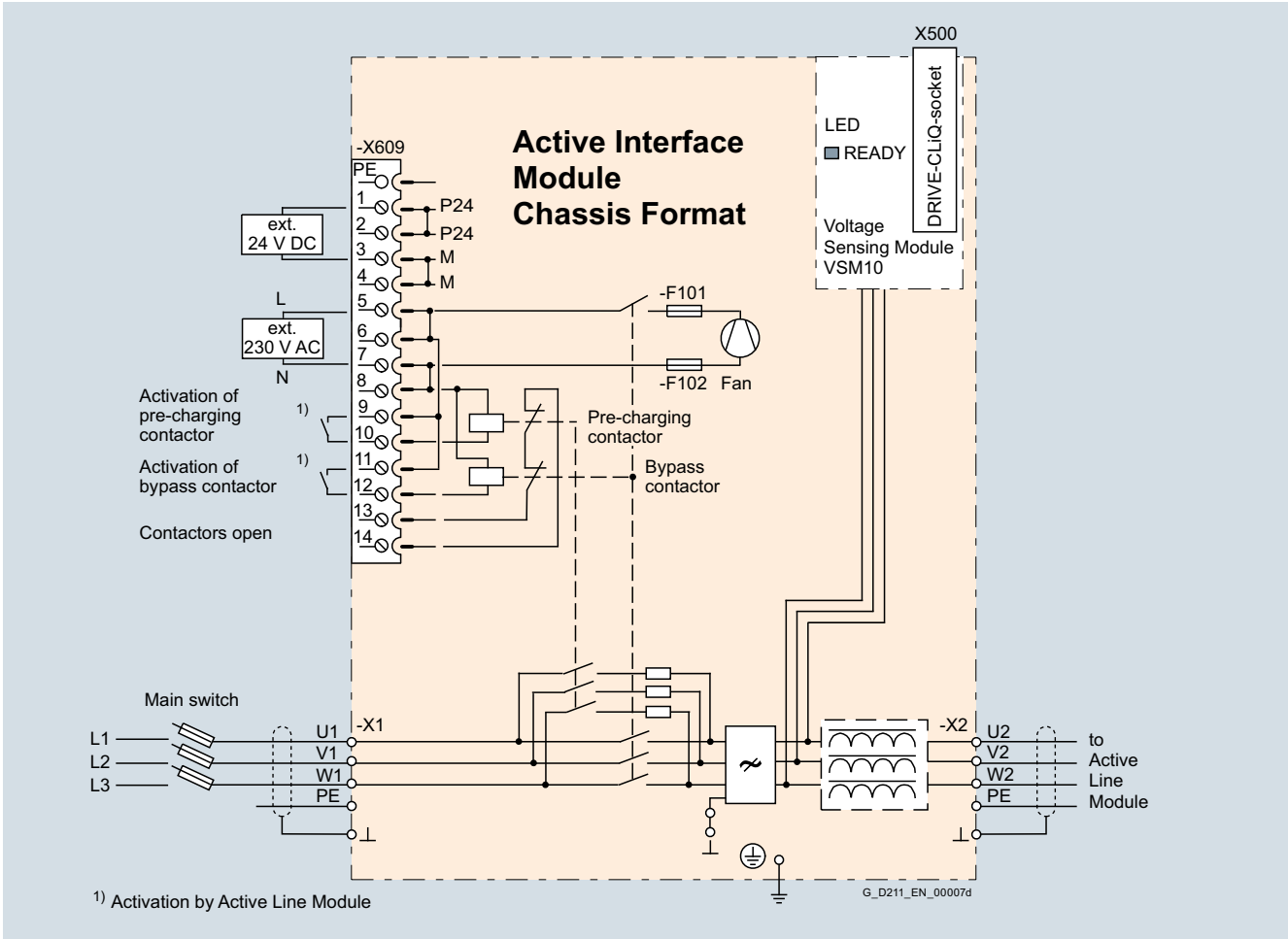

Connection example of an Active Interface Module with integrated bypass contactor (frame sizes FI and GI)

3

SINAMICS S120 Chassis Format Converter Units

Air-cooled units

Active Interface Modules

Integration (continued)

3

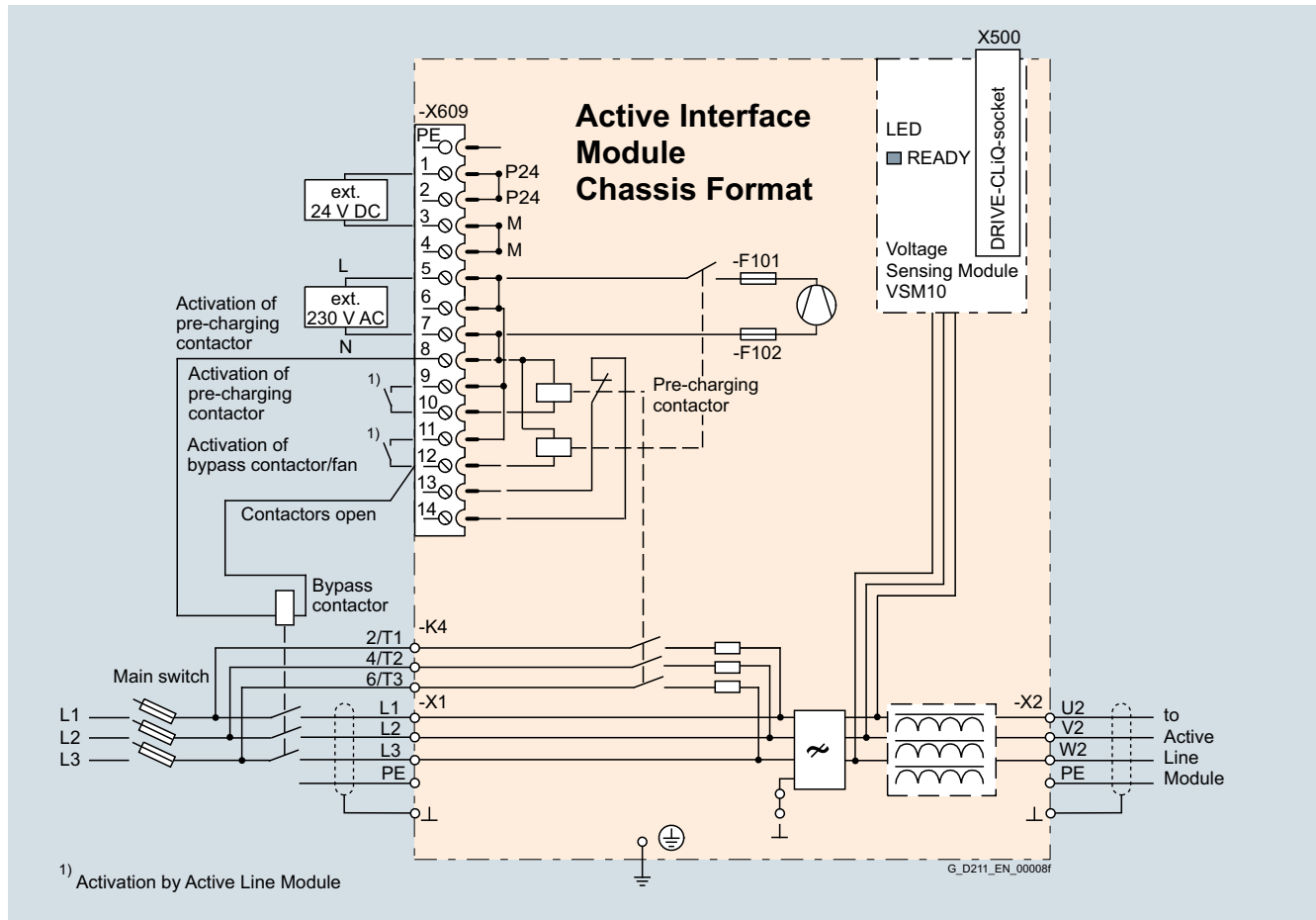

Connection example of an Active Interface Module with externally mounted bypass contactor (frame sizes HI and JI)

SINAMICS S120 Chassis Format Converter Units

Air-cooled units

Active Interface Modules

Technical specifications

Line voltage 380 ... 480 V 3 AC		Active Interface Modules			
		6SL3300-7TE32-6AA0	6SL3300-7TE32-6AA3	6SL3300-7TE33-8AA0	6SL3300-7TE35-0AA0
Suitable for Active Line Module					
• Rated power at 400 V	kW	132	160	235	300
- Air-cooled		6SL3330-7TE32-1AA3	6SL3330-7TE32-6AA3	6SL3330-7TE33-8AA3	6SL3330-7TE35-0AA3
- Liquid-cooled		–	–	–	6SL3335-7TE35-0AA3
Rated current	A	210	260	380	490
Bypass contactor		Included	Included	Included	Included
Current demand					
• 24 V DC auxiliary power supply	A	0.17	0.17	0.17	0.17
• 230 V 2 AC					
- Inrush current	A	1.25	1.25	2.5	2.5
- Holding current	A	0.6	0.6	1.2	1.2
DC link capacitance of drive line-up, max. ¹⁾	μF	41600	41600	76800	76800
Power loss, max. ²⁾					
• At 50 Hz 400 V	kW	2.1	2.2	3.0	3.9
• At 60 Hz 460 V	kW	2.1	2.2	3.0	3.9
Cooling air requirement	m ³ /s	0.24	0.24	0.47	0.47
Line/load connection L1, L2, L3 / U2, V2, W2		Flat connector for M10 screw	Flat connector for M10 screw	Flat connector for M10 screw	Flat connector for M10 screw
• Conductor cross section, max. (IEC)	mm ²	2 × 185	2 × 185	2 × 185	2 × 185
PE/GND connection		2 × M10 nut	2 × M10 nut	2 × M10 nut	2 × M10 nut
• Conductor cross section, max. (IEC)	mm ²	2 × 185	2 × 185	2 × 185	2 × 185
Degree of protection		IP20	IP20	IP20	IP20
Dimensions					
• Width	mm	325	325	325	325
• Height	mm	1400	1400	1533	1533
• Depth	mm	355	355	544	544
Weight, approx.	kg	135	135	190	190
Frame size		FI	FI	GI	GI
Minimum short-circuit current ³⁾	A	6200	10500	10500	8000

¹⁾ Information on higher capacities is included in the [SINAMICS Low Voltage Engineering Manual](#).

²⁾ The specified power loss represents the maximum value at 100% utilization. The value is lower under normal operating conditions.

³⁾ Current required for reliable triggering of the protective devices.

SINAMICS S120 Chassis Format Converter Units

Air-cooled units

Active Interface Modules

Technical specifications (continued)

Line voltage 380 ... 480 V 3 AC		Active Interface Modules			
Suitable for Active Line Module		6SL3300-7TE38-4AA0		6SL3300-7TE41-4AA0	
		380	450/500	630	800/900
• Rated power at 400 V	kW	380	450/500	630	800/900
- Air-cooled		6SL3330-7TE36-1AA3	6SL3330-7TE37-5AA3 6SL3330-7TE38-4AA3	6SL3330-7TE41-0AA3	6SL3330-7TE41-2AA3 6SL3330-7TE41-4AA3
- Liquid-cooled		6SL3335-7TE36-1AA3	6SL3335-7TE38-4AA3	6SL3335-7TE41-0AA3	6SL3335-7TE41-4AA3
Rated current	A	605	745/840	985	1260/1405
Bypass contactor		3RT1476-6AP36	3WL1110-2BB34-4AN2-Z C22 ¹⁾	3WL1112-2BB34-4AN2-Z C22 ¹⁾	3WL1116-2BB34-4AN2-Z C22 ¹⁾
Current demand					
• 24 V DC auxiliary power supply	A	0.17	0.17	0.17	0.17
• 230 V 2 AC					
- Inrush current	A	9.9	9.9	10.5	10.5
- Holding current	A	4.6	4.6	4.9	4.9
DC link capacitance of the drive line-up, max. ²⁾	µF	134400	134400	230400	230400
Power loss, max. ³⁾					
• At 50 Hz 400 V	kW	5.5	6.1	7.5	8.5
• At 60 Hz 460 V	kW	5.5	6.1	7.5	8.5
Cooling air requirement	m ³ /s	0.4	0.4	0.4	0.4
Line/load connection L1, L2, L3 / U2, V2, W2		4 × hole for M12	4 × hole for M12	3 × hole for M12	3 × hole for M12
• Conductor cross section, max. (IEC)	mm ²	4 × 240	4 × 240	6 × 240	6 × 240
PE/GND connection		2 × M12 nut	2 × M12 nut	4 × M12 nut	4 × M12 nut
• Conductor cross section, max. (IEC)	mm ²	2 × 240	2 × 240	4 × 240	4 × 240
Degree of protection		IP00	IP00	IP00	IP00
Dimensions					
• Width	mm	305	305	505	505
• Height	mm	1750	1750	1750	1750
• Depth	mm	544	544	544	544
Weight, approx.	kg	390	390	480	480
Frame size		HI	HI	JI	JI
Minimum short-circuit current ⁴⁾	A	9200	8800/10400	16000	21000

¹⁾ The breakers must always be switched ON and OFF by the sequence control. An interlocking set 3WL9111-0BA21-0AA0 as described in Catalog LV 10 should be provided for the bypass contactor to exclude the risk of unintentional manual operation. Manual operation bypasses the pre-charging circuit and can therefore destroy the Active Line Module.

²⁾ Information on higher capacities is included in the [SINAMICS Low Voltage Engineering Manual](#).

³⁾ The specified power loss represents the maximum value at 100% utilization. The value is lower under normal operating conditions.

⁴⁾ Current required for reliably triggering protective devices.

SINAMICS S120 Chassis Format Converter Units

Air-cooled units

Active Interface Modules

Technical specifications (continued)

Line voltage 500 ... 690 V 3 AC		Active Interface Modules			
		6SL3300-7TG35-8AA0	6SL3300-7TG37-4AA0	6SL3300-7TG41-3AA0	
Suitable for Active Line Module					
• Rated power at 690 V	kW	630	800	1100	1400
- Air-cooled		6SL3330-7TG35-8AA3	6SL3330-7TG37-4AA3	6SL3330-7TG41-0AA3	6SL3330-7TG41-3AA3
- Liquid-cooled		6SL3335-7TG35-8AA3	6SL3335-7TG37-4AA3	–	–
Rated current	A	575	735	1025	1270
Bypass contactor		3RT1476-6AP36	3RT1476-6AP36 (3 units)	3WL 1212-4BB34-4AN2-Z C22 ¹⁾	3WL 1216-4BB34-4AN2-Z C22 ¹⁾
Current demand					
• 24 V DC auxiliary power supply	A	0.17	0.17	0.17	0.17
• 230 V 2 AC					
- Inrush current	A	9.9	10.5	10.5	10.5
- Holding current	A	4.6	4.9	4.9	4.9
DC link capacitance of the drive line-up, max. ²⁾	µF	59200	153600	153600	153600
Power loss, max. ³⁾					
• At 50 Hz 690 V	kW	6.8	9.0	9.2	9.6
• At 60 Hz 575 V	kW	6.8	9.0	9.2	9.6
Cooling air requirement	m ³ /s	0.4	0.4	0.4	0.4
Line/load connection L1, L2, L3 / U2, V2, W2		4 × hole for M12	3 × hole for M12	3 × hole for M12	3 × hole for M12
• Conductor cross section, max. (IEC)	mm ²	4 × 240	6 × 240	6 × 240	6 × 240
PE/GND connection		2 × M12 nut	4 × M12 nut	4 × M12 nut	4 × M12 nut
• Conductor cross section, max. (IEC)	mm ²	2 × 240	4 × 240	4 × 240	4 × 240
Degree of protection		IP00	IP00	IP00	IP00
Dimensions					
• Width	mm	305	505	505	505
• Height	mm	1750	1750	1750	1750
• Depth	mm	544	544	544	544
Weight, approx.	kg	390	430	530	530
Frame size		HI	JI	JI	JI
Minimum short-circuit current ⁴⁾	A	8400	10500	16000	20000

¹⁾ The breakers must always be switched ON and OFF by the sequence control. An interlocking set 3WL9111-0BA21-0AA0 as described in Catalog LV 10 should be provided for the bypass contactor to exclude the risk of unintentional manual operation. Manual operation bypasses the pre-charging circuit and can therefore destroy the Active Line Module.

²⁾ Information on higher capacities is included in the SINAMICS Low Voltage Engineering Manual.

³⁾ The specified power loss represents the maximum value at 100% utilization. The value is lower under normal operating conditions.

⁴⁾ Current required for reliably triggering protective devices.

SINAMICS S120 Chassis Format Converter Units

Air-cooled units

Motor Modules

Overview



A Motor Module comprises a self-commutated inverter with IGBTs. It generates a variable voltage with variable frequency from the DC link voltage that feeds the connected motor.

Multiple Motor Modules can be operated on a single DC link. This permits energy to be transferred between the Motor Modules. This means that if one Motor Module operating in generator mode produces energy, the energy can be used by another Motor Module operating in motor mode.

Motor Modules are controlled by a Control Unit.

Design

The Motor Modules in the chassis format have the following interfaces as standard:

- 1 motor connection
- 1 connection for the 24 V DC electronics power supply
- 1 DC link connection (DCP, DCN) for connecting to the supply DC link
- 1 DC link connection (DCPA, DCNA) for connecting a Braking Module
- 1 DC link connection (DCPS, DCNS) for connecting a dv/dt filter
- 3 DRIVE-CLiQ sockets
- 1 temperature sensor input (KTY84-130, PTC or Pt100)
- 1 connection for Safe Brake Adapter
- 1 connection for Safety Integrated
- 2 PE connections

The status of the Motor Modules is indicated via three LEDs.

The scope of supply of the Motor Modules includes:

- DRIVE-CLiQ cable for connection to the Control Unit
- DRIVE-CLiQ cable for connection to the next Motor Module
- 1 set of warning labels in 30 languages (BG, CN, CZ, DE, DK, EE, ES, FI, FR, GB, GR, HU, IE, IS, IT, JP, KR, LT, LV, MT, NL, NO, PL, PT, RO, RU, SE, SI, SK, TR)

Selection and ordering data

Type rating at 400 V or 690 V kW	Rated output current A	Motor Module Article No.
Line voltage 380 ... 480 V 3 AC (DC link voltage 510 ... 720 V DC)		
110	210	6SL3320-1TE32-1AA3
132	260	6SL3320-1TE32-6AA3
160	310	6SL3320-1TE33-1AA3
200	380	6SL3320-1TE33-8AA3
250	490	6SL3320-1TE35-0AA3
315	605	6SL3320-1TE36-1AA3
400	745	6SL3320-1TE37-5AA3
450	840	6SL3320-1TE38-4AA3
560	985	6SL3320-1TE41-0AA3
710	1260	6SL3320-1TE41-2AA3
800	1405	6SL3320-1TE41-4AA3
Line voltage 500 ... 690 V 3 AC (DC link voltage 675 ... 1035 V DC)		
75	85	6SL3320-1TG28-5AA3
90	100	6SL3320-1TG31-0AA3
110	120	6SL3320-1TG31-2AA3
132	150	6SL3320-1TG31-5AA3
160	175	6SL3320-1TG31-8AA3
200	215	6SL3320-1TG32-2AA3
250	260	6SL3320-1TG32-6AA3
315	330	6SL3320-1TG33-3AA3
400	410	6SL3320-1TG34-1AA3
450	465	6SL3320-1TG34-7AA3
560	575	6SL3320-1TG35-8AA3
710	735	6SL3320-1TG37-4AA3
800	810	6SL3320-1TG38-1AA3
900	910	6SL3320-1TG38-8AA3
1000	1025	6SL3320-1TG41-0AA3
1200	1270	6SL3320-1TG41-3AA3

Description	Article No.
Accessories for re-ordering	
Dust protection blanking plugs (50 units) For DRIVE-CLiQ port	6SL3066-4CA00-0AA0

For motor-side components and Braking Modules, see System components.

SINAMICS S120 Chassis Format Converter Units

Air-cooled units

Motor Modules

Integration

The Motor Modules communicate with the higher-level control module via DRIVE-CLiQ. The control module in this case can be a CU320-2 or a SIMOTION D Control Unit.

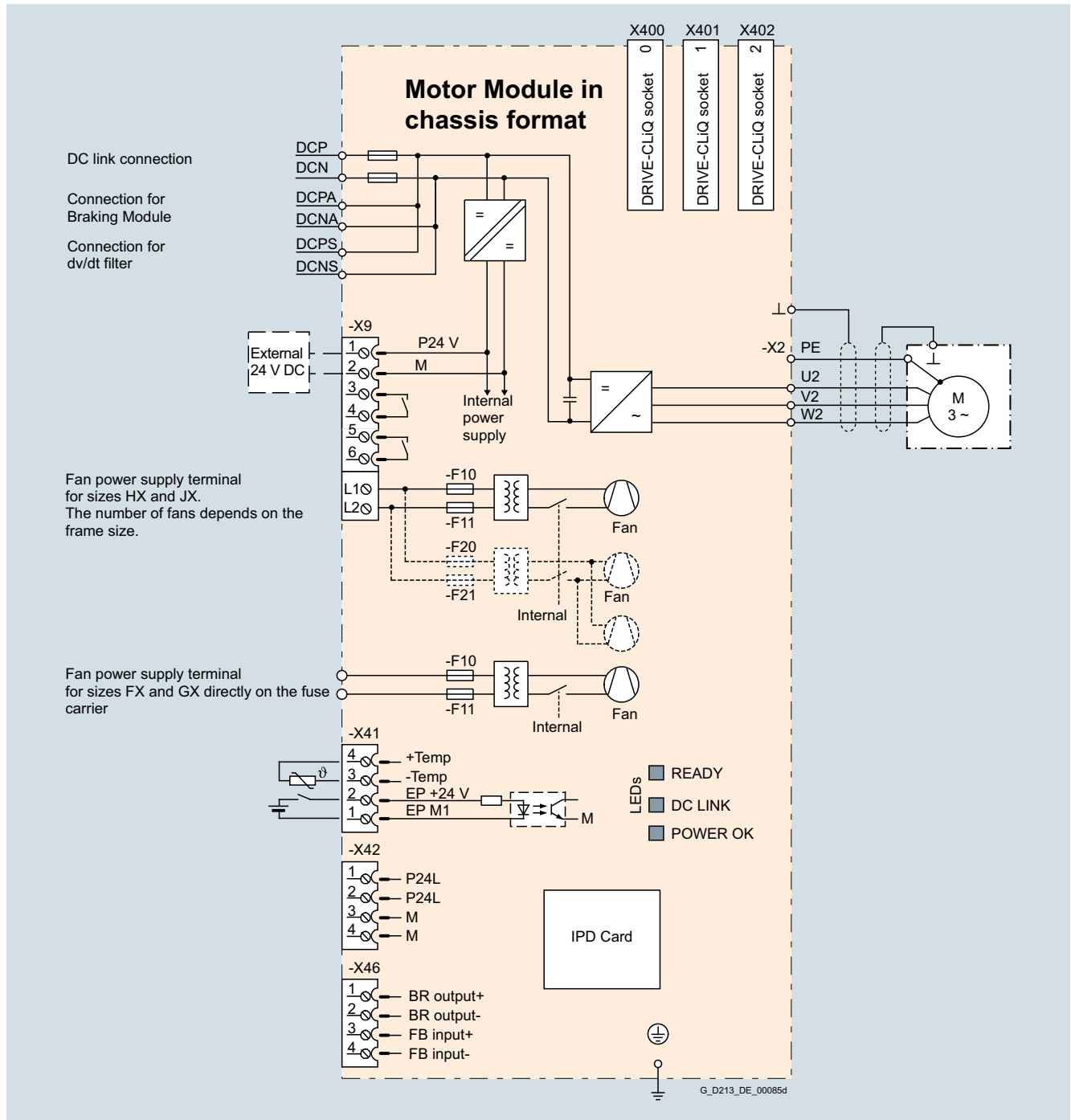

Connection example of a Motor Module

3

SINAMICS S120 Chassis Format Converter Units

Air-cooled units

Motor Modules

Technical specifications

General technical specifications

Electrical specifications	
Efficiency	>98.5 %
DC link voltage (up to 2000 m above sea level)	510 ... 720 V DC (line supply voltage 380 ... 480 V 3 AC) or 675 ... 1035 V DC (line supply voltage 500 ... 690 V 3 AC)
Output frequency ¹⁾	
• Control type Servo	0 ... 550 Hz
• Control type Vector	0 ... 550 Hz
• Control mode V/f	0 ... 550 Hz
Safety Integrated	Safety Integrity Level 2 (SIL2) acc. to IEC 61508, Performance Level d (PLd) acc. to EN ISO 13849-1 and Control Category 3 acc. to EN ISO 13849-1

3

¹⁾ Please note:

- The correlation between the maximum output frequency, pulse frequency and current derating. Higher output frequencies on request
- The correlation between the minimum output frequency and permissible output current (current derating). [Information is provided in the SINAMICS Low Voltage Engineering Manual.](#)

SINAMICS S120 Chassis Format Converter Units

Air-cooled units

Motor Modules

Technical specifications (continued)

Line voltage 380 ... 480 V 3 AC DC link voltage 510 ... 720 V DC	Motor Modules					
		6SL3320-1TE32-1AA3	6SL3320-1TE32-6AA3	6SL3320-1TE33-1AA3	6SL3320-1TE33-8AA3	6SL3320-1TE35-0AA3
Type rating						
• At I_L (50 Hz 400 V) ¹⁾	kW	110	132	160	200	250
• At I_H (50 Hz 400 V) ¹⁾	kW	90	110	132	160	200
• At I_L (60 Hz 460 V) ²⁾	hp	150	200	250	300	400
• At I_H (60 Hz 460 V) ²⁾	hp	150	200	200	250	350
Output current						
• Rated current $I_{rated O}$	A	210	260	310	380	490
• Base-load current I_L ³⁾	A	205	250	302	370	477
• Base-load current I_H ⁴⁾	A	178	233	277	340	438
• Maximum current $I_{max O}$	A	307	375	453	555	715
DC link current						
• Rated current $I_{rated DC}$ when supplied via						
- Basic/Smart Line Module	A	252	312	372	456	588
- Active Line Module	A	227	281	335	411	529
• Base-load current $I_{L DC}$ ³⁾ when supplied via						
- Basic/Smart Line Module	A	245	304	362	444	573
- Active Line Module	A	221	273	326	400	515
• Base-load current $I_{H DC}$ ⁴⁾ when supplied via						
- Basic/Smart Line Module	A	224	277	331	405	523
- Active Line Module	A	202	250	298	365	470
Current demand						
• 24 V DC auxiliary power supply	A	0.8	0.8	0.9	0.9	0.9
• 400 V AC	A	0.63	1.13	1.8	1.8	1.8
DC link capacitance						
	μF	4200	5200	6300	7800	9600
Pulse frequency ⁵⁾						
• Rated frequency	kHz	2	2	2	2	2
• Pulse frequency, max.						
- Without current derating	kHz	2	2	2	2	2
- With current derating	kHz	8	8	8	8	8
Power loss, max. ⁶⁾						
• At 50 Hz 400 V	kW	1.86	2.5	2.96	3.67	4.28
• At 60 Hz 460 V	kW	1.94	2.6	3.1	3.8	4.5
Cooling air requirement						
	m ³ /s	0.17	0.23	0.36	0.36	0.36
Sound pressure level L_{pA} (1 m) at 50/60 Hz						
	dB	64/67	64/67	69/73	69/73	69/73
DC link connection						
DCP, DCN		M10 screw	M10 screw	M10 screw	M10 screw	M10 screw
• Conductor cross section, max. (IEC)	mm ²	2 × 185	2 × 185	2 × 240	2 × 240	2 × 240
Connection for Braking Module						
DCPA, DCNA ⁷⁾		Threaded bolt M6	Threaded bolt M6	Threaded bolt M6	Threaded bolt M6	Threaded bolt M6
Connection for dv/dt filter						
DCPS, DCNS		M8 screw	M8 screw	M8 screw	M8 screw	M8 screw
• Conductor cross section, max. (IEC)	mm ²	1 × 35	1 × 35	1 × 70	1 × 70	1 × 70
Motor connection						
U2, V2, W2		M10 screw	M10 screw	M10 screw	M10 screw	M10 screw
• Conductor cross section, max. (IEC)	mm ²	2 × 185	2 × 185	2 × 240	2 × 240	2 × 240
Cable length, max. ⁸⁾						
• Shielded	m	300	300	300	300	300
• Unshielded	m	450	450	450	450	450

For footnotes, see next page.

SINAMICS S120 Chassis Format Converter Units

Air-cooled units

Motor Modules

Technical specifications (continued)

Line voltage 380 ... 480 V 3 AC DC link voltage 510 ... 720 V DC		Motor Modules				
		6SL3320-1TE32-1AA3	6SL3320-1TE32-6AA3	6SL3320-1TE33-1AA3	6SL3320-1TE33-8AA3	6SL3320-1TE35-0AA3
PE1/GND connection		M10 screw	M10 screw	M10 screw	M10 screw	M10 screw
• Conductor cross section, max. (IEC)	mm ²	2 × 185	2 × 185	2 × 240	2 × 240	2 × 240
PE2/GND connection		M10 screw	M10 screw	M10 screw	M10 screw	M10 screw
• Conductor cross section, max. (IEC)	mm ²	2 × 185	2 × 185	2 × 240	2 × 240	2 × 240
Degree of protection		IP20	IP20	IP20	IP20	IP20
Dimensions						
• Width	mm	326	326	326	326	326
• Height	mm	1400	1400	1533	1533	1533
• Depth	mm	356	356	545	545	545
Weight, approx.		kg	95	95	136	136
Frame size			FX	FX	GX	GX

¹⁾ Rated output of a typical 6-pole standard induction motor based on I_L or I_H for 400 V 3 AC 50 Hz.

²⁾ Rated output of a typical 6-pole standard induction motor based on I_L or I_H for 460 V 3 AC 60 Hz.

³⁾ The base-load current I_L is based on a load cycle of 110 % for 60 s or 150 % for 10 s with a load cycle duration of 300 s.

⁴⁾ The base-load current I_H is based on a duty cycle of 150 % for 60 s or 160 % for 10 s with a duty cycle duration of 300 s.

⁵⁾ Information regarding the correlation between the pulse frequency and maximum output current/output frequency is provided in the Engineering Manual SINAMICS Low Voltage Engineering Manual.

⁶⁾ The specified power loss represents the maximum value at 100% utilization. The value is lower under normal operating conditions.

⁷⁾ The connecting cables are included in the scope of supply of the Braking Module.

⁸⁾ Total of all motor cables and DC link. Longer cable lengths for specific configurations are available on request. For additional information, please refer to the SINAMICS Low Voltage Engineering Manual.

SINAMICS S120 Chassis Format Converter Units

Air-cooled units

Motor Modules

Technical specifications (continued)

Line voltage 380 ... 480 V 3 AC DC link voltage 510 ... 720 V DC		Motor Modules		
		6SL3320-1TE36-1AA3	6SL3320-1TE37-5AA3	6SL3320-1TE38-4AA3
Type rating				
• At I_L (50 Hz 400 V) ¹⁾	kW	315	400	450
• At I_H (50 Hz 400 V) ¹⁾	kW	250	315	400
• At I_L (60 Hz 460 V) ²⁾	hp	500	600	700
• At I_H (60 Hz 460 V) ²⁾	hp	350	450	600
Output current				
• Rated current $I_{rated O}$	A	605	745	840
• Base-load current I_L ³⁾	A	590	725	820
• Base-load current I_H ⁴⁾	A	460	570	700
• Maximum current $I_{max O}$	A	885	1087	1230
DC link current				
• Rated current $I_{rated DC}$ when supplied via				
- Basic/Smart Line Module	A	726	894	1008
- Active Line Module	A	653	805	907
• Base-load current $I_{L DC}$ ³⁾ when supplied via				
- Basic/Smart Line Module	A	707	871	982
- Active Line Module	A	636	784	884
• Base-load current $I_{H DC}$ ⁴⁾ when supplied via				
- Basic/Smart Line Module	A	646	795	897
- Active Line Module	A	581	716	807
Current demand				
• 24 V DC auxiliary power supply	A	1.0	1.0	1.0
• 400 V AC	A	3.6	3.6	3.6
DC link capacitance	μF	12600	15600	16800
Pulse frequency ⁵⁾				
• Rated frequency	kHz	1.25	1.25	1.25
• Pulse frequency, max.				
- Without current derating	kHz	1.25	1.25	1.25
- With current derating	kHz	7.5	7.5	7.5
Power loss, max. ⁶⁾				
• At 50 Hz 400 V	kW	5.84	6.68	7.15
• At 60 Hz 460 V	kW	6.3	7.3	7.8
Cooling air requirement	m ³ /s	0.78	0.78	0.78
Sound pressure level L_{pA} (1 m) at 50/60 Hz	dB	70/73	70/73	70/73
DC link connection DCP, DCN		4 × hole for M10 Busbar	4 × hole for M10 Busbar	4 × hole for M10 Busbar
Connection for Braking Module DCPA, DCNA ⁷⁾		Connection for connection clip	Connection for connection clip	Connection for connection clip
Connection for dv/dt filter DCPS, DCNS		M10 screw	M10 screw	M10 screw
• Conductor cross section, max. (IEC)	mm ²	1 × 185	1 × 185	1 × 185
Motor connection U2, V2, W2		2 × M12 screw	2 × M12 screw	2 × M12 screw
• Conductor cross section, max. (IEC)	mm ²	4 × 240	4 × 240	4 × 240
Cable length, max. ⁸⁾				
• Shielded	m	300	300	300
• Unshielded	m	450	450	450

SINAMICS S120 Chassis Format Converter Units

Air-cooled units

Motor Modules

Technical specifications (continued)

Line voltage 380 ... 480 V 3 AC DC link voltage 510 ... 720 V DC		Motor Modules		
		6SL3320-1TE36-1AA3	6SL3320-1TE37-5AA3	6SL3320-1TE38-4AA3
PE1/GND connection		M12 screw	M12 screw	M12 screw
• Conductor cross section, max. (IEC)	mm ²	240	240	240
PE2/GND connection		2 × M12 screw	2 × M12 screw	2 × M12 screw
• Conductor cross section, max. (IEC)	mm ²	2 × 240	2 × 240	2 × 240
Degree of protection		IP00	IP00	IP00
Dimensions				
• Width	mm	503	503	503
• Height	mm	1475	1475	1475
• Depth	mm	547	547	547
Weight, approx.	kg	290	290	290
Frame size		HX	HX	HX

¹⁾ Rated output of a typical 6-pole standard induction motor based on I_L or I_H for 400 V 3 AC 50 Hz.

²⁾ Rated output of a typical 6-pole standard induction motor based on I_L or I_H for 460 V 3 AC 60 Hz.

³⁾ The base-load current I_L is based on a load cycle of 110 % for 60 s or 150 % for 10 s with a load cycle duration of 300 s.

⁴⁾ The base-load current I_H is based on a duty cycle of 150 % for 60 s or 160 % for 10 s with a duty cycle duration of 300 s.

⁵⁾ [Information regarding the correlation between the pulse frequency and maximum output current/output frequency is provided in the Engineering Manual SINAMICS Low Voltage Engineering Manual.](#)

⁶⁾ The specified power loss represents the maximum value at 100% utilization. The value is lower under normal operating conditions.

⁷⁾ The connecting cables are included in the scope of supply of the Braking Module.

⁸⁾ Total of all motor cables and DC link. Longer cable lengths for specific configurations are available on request. [For additional information, please refer to the SINAMICS Low Voltage Engineering Manual.](#)

SINAMICS S120 Chassis Format Converter Units

Air-cooled units

Motor Modules

Technical specifications (continued)

Line voltage 380 ... 480 V 3 AC DC link voltage 510 ... 720 V DC		Motor Modules		
		6SL3320-1TE41-0AA3	6SL3320-1TE41-2AA3	6SL3320-1TE41-4AA3
Type rating				
• At I_L (50 Hz 400 V) ¹⁾	kW	560	710	800
• At I_H (50 Hz 400 V) ¹⁾	kW	450	560	710
• At I_L (60 Hz 460 V) ²⁾	hp	800	1000	1150
• At I_H (60 Hz 460 V) ²⁾	hp	700	900	1000
Output current				
• Rated current $I_{rated O}$	A	985	1260	1405
• Base-load current I_L ³⁾	A	960	1230	1370
• Base-load current I_H ⁴⁾	A	860	1127	1257
• Maximum current $I_{max O}$	A	1440	1845	2055
DC link current				
• Rated current $I_{rated DC}$ when supplied via				
- Basic/Smart Line Module	A	1182	1512	1686
- Active Line Module	A	1064	1361	1517
• Base-load current $I_{L DC}$ ³⁾ when supplied via				
- Basic/Smart Line Module	A	1152	1474	1643
- Active Line Module	A	1037	1326	1479
• Base-load current $I_{H DC}$ ⁴⁾ when supplied from				
- Basic/Smart Line Module	A	1051	1345	1500
- Active Line Module	A	946	1211	1350
Current demand				
• 24 V DC auxiliary power supply	A	1.25	1.4	1.4
• 400 V AC	A	5.4	5.4	5.4
DC link capacitance				
	μF	18900	26100	28800
Pulse frequency ⁵⁾				
• Rated pulse frequency	kHz	1.25	1.25	1.25
• Pulse frequency, max.				
- Without current derating	kHz	1.25	1.25	1.25
- With current derating	kHz	7.5	7.5	7.5
Power loss, max. ⁶⁾				
• At 50 Hz 400 V	kW	9.5	11.1	12.0
• At 60 Hz 460 V	kW	10.2	12.0	13.0
Cooling air requirement				
	m ³ /s	1.08	1.08	1.08
Sound pressure level L_{pA} (1 m) at 50/60 Hz				
	dB	71/73	71/73	71/73
DC link connection DCP, DCN				
		4 × hole for M10 Busbar	4 × hole for M10 Busbar	4 × hole for M10 Busbar
Connection for Braking Module DCPA, DCNA ⁷⁾				
		Connection for connection clip	Connection for connection clip	Connection for connection clip
Connection for dv/dt filter DCPS, DCNS				
• Conductor cross section, max. (IEC)	mm ²	2 × M10 screw 2 × 185	2 × M10 screw 2 × 185	2 × M10 screw 2 × 185
Motor connection U2, V2, W2				
• Conductor cross section, max. (IEC)	mm ²	3 × M12 screw 6 × 240	3 × M12 screw 6 × 240	3 × M12 screw 6 × 240
Cable length, max. ⁸⁾				
• Shielded	m	300	300	300
• Unshielded	m	450	450	450

SINAMICS S120 Chassis Format Converter Units

Air-cooled units

Motor Modules

Technical specifications (continued)

Line voltage 380 ... 480 V 3 AC DC link voltage 510 ... 720 V DC		Motor Modules		
		6SL3320-1TE41-0AA3	6SL3320-1TE41-2AA3	6SL3320-1TE41-4AA3
PE1/GND connection		M12 screw	M12 screw	M12 screw
• Conductor cross section, max. (IEC)	mm ²	240	240	240
PE2/GND connection		3 × M12 screw	3 × M12 screw	3 × M12 screw
• Conductor cross section, max. (IEC)	mm ²	3 × 240	3 × 240	3 × 240
Degree of protection		IP00	IP00	IP00
Dimensions				
• Width	mm	704	704	704
• Height	mm	1475	1475	1475
• Depth	mm	549	549	549
Weight, approx.	kg	450	450	450
Frame size		JX	JX	JX

¹⁾ Rated output of a typical 6-pole standard induction motor based on I_L or I_H for 400 V 3 AC 50 Hz.

²⁾ Rated output of a typical 6-pole standard induction motor based on I_L or I_H for 460 V 3 AC 60 Hz.

³⁾ The base-load current I_L is based on a load cycle of 110 % for 60 s or 150 % for 10 s with a load cycle duration of 300 s.

⁴⁾ The base-load current I_H is based on a duty cycle of 150 % for 60 s or 160 % for 10 s with a duty cycle duration of 300 s.

⁵⁾ Information regarding the correlation between the pulse frequency and maximum output current/output frequency is provided in the Engineering Manual SINAMICS Low Voltage Engineering Manual.

⁶⁾ The specified power loss represents the maximum value at 100% utilization. The value is lower under normal operating conditions.

⁷⁾ The connecting cables are included in the scope of supply of the Braking Module.

⁸⁾ Total of all motor cables and DC link. Longer cable lengths for specific configurations are available on request. For additional information, please refer to the SINAMICS Low Voltage Engineering Manual.

SINAMICS S120 Chassis Format Converter Units

Air-cooled units

Motor Modules

Technical specifications (continued)

Line voltage 500 ... 690 V 3 AC DC link voltage 675 ... 1035 V DC		Motor Modules			
		6SL3320-1TG28-5AA3	6SL3320-1TG31-0AA3	6SL3320-1TG31-2AA3	6SL3320-1TG31-5AA3
Type rating					
• At I_L (50 Hz 690 V) ¹⁾	kW	75	90	110	132
• At I_H (50 Hz 690 V) ¹⁾	kW	55	75	90	110
• At I_L (50 Hz 500 V) ¹⁾	kW	55	55	75	90
• At I_H (50 Hz 500 V) ¹⁾	kW	45	55	75	90
• At I_L (60 Hz 575 V) ²⁾	hp	75	75	100	150
• At I_H (60 Hz 575 V) ²⁾	hp	75	75	100	125
Output current					
• Rated current $I_{rated O}$	A	85	100	120	150
• Base-load current $I_L^{(3)}$	A	80	95	115	142
• Base-load current $I_H^{(4)}$	A	76	89	107	134
• Maximum current $I_{max O}$	A	120	142	172	213
DC link current					
• Rated current $I_{rated DC}$ when supplied via					
- Basic/Smart Line Module	A	102	120	144	180
- Active Line Module	A	92	108	130	162
• Base-load current $I_{L DC}^{(3)}$ when supplied via					
- Basic/Smart Line Module	A	99	117	140	175
- Active Line Module	A	89	105	126	157
• Base-load current $I_{H DC}^{(4)}$ when supplied via					
- Basic/Smart Line Module	A	90	106	128	160
- Active Line Module	A	81	96	115	144
Current demand					
• 24 V DC auxiliary power supply	A	0.8	0.8	0.8	0.8
• 500 V AC	A	0.7	0.7	0.7	0.7
• 690 V AC	A	0.4	0.4	0.4	0.4
DC link capacitance					
	μF	1200	1200	1600	2800
Pulse frequency ⁵⁾					
• Rated frequency	kHz	1.25	1.25	1.25	1.25
• Pulse frequency, max.					
- Without current derating	kHz	1.25	1.25	1.25	1.25
- With current derating	kHz	7.5	7.5	7.5	7.5
Power loss, max. ⁶⁾					
• At 50 Hz 690 V	kW	1.17	1.43	1.89	1.8
• At 60 Hz 575 V	kW	1.1	1.3	1.77	1.62
Cooling air requirement					
	m ³ /s	0.17	0.17	0.17	0.17
Sound pressure level L_{pA} (1 m) at 50/60 Hz					
	dB	64/67	64/67	64/67	64/67
DC link connection DCP, DCN					
• Conductor cross section, max. (IEC)	mm ²	M10 screw 2 × 185	M10 screw 2 × 185	M10 screw 2 × 185	M10 screw 2 × 185
Connection for Braking Module DCPA, DCNA ⁷⁾					
		M6 stud	M6 stud	M6 stud	M6 stud
Connection for dv/dt filter DCPS, DCNS					
• Conductor cross section, max. (IEC)	mm ²	M8 screw 1 × 70	M8 screw 1 × 70	M8 screw 1 × 70	M8 screw 1 × 70
Motor connection U2, V2, W2					
• Conductor cross section, max. (IEC)	mm ²	M10 screw 2 × 185	M10 screw 2 × 185	M10 screw 2 × 185	M10 screw 2 × 185

For footnotes, see next page.

SINAMICS S120 Chassis Format Converter Units

Air-cooled units

Motor Modules

Technical specifications (continued)

Line voltage 500 ... 690 V 3 AC DC link voltage 675 ... 1035 V DC		Motor Modules			
		6SL3320-1TG28-5AA3	6SL3320-1TG31-0AA3	6SL3320-1TG31-2AA3	6SL3320-1TG31-5AA3
Cable length, max. ⁸⁾					
• Shielded	m	300	300	300	300
• Unshielded	m	450	450	450	450
PE1/GND connection		M10 screw	M10 screw	M10 screw	M10 screw
• Conductor cross section, max. (IEC)	mm ²	2 × 185	2 × 185	2 × 185	2 × 185
PE2/GND connection		M10 screw	M10 screw	M10 screw	M10 screw
• Conductor cross section, max. (IEC)	mm ²	2 × 185	2 × 185	2 × 185	2 × 185
Degree of protection		IP20	IP20	IP20	IP20
Dimensions					
• Width	mm	326	326	326	326
• Height	mm	1400	1400	1400	1400
• Depth	mm	356	356	356	356
Weight, approx.	kg	95	95	95	95
Frame size		FX	FX	FX	FX

¹⁾ Rated output of a typical 6-pole standard induction motor based on I_L or I_H for 500 V or 690 V 3 AC 50 Hz.

²⁾ Rated output of a typical 6-pole standard induction motor based on I_L or I_H for 575 V 3 AC 60 Hz.

³⁾ The base-load current I_L is based on a load cycle of 110 % for 60 s or 150 % for 10 s with a load cycle duration of 300 s.

⁴⁾ The base-load current I_H is based on a duty cycle of 150 % for 60 s or 160 % for 10 s with a duty cycle duration of 300 s.

⁵⁾ Information regarding the correlation between the pulse frequency and maximum output current/output frequency is provided in the Engineering Manual. SINAMICS Low Voltage Engineering Manual.

⁶⁾ The specified power loss represents the maximum value at 100% utilization. The value is lower under normal operating conditions.

⁷⁾ The connecting cables are included in the scope of supply of the Braking Module.

⁸⁾ Total of all motor cables and DC link. Longer cable lengths for specific configurations are available on request. For additional information, please refer to the SINAMICS Low Voltage Engineering Manual.

SINAMICS S120 Chassis Format Converter Units

Air-cooled units

Motor Modules

Technical specifications (continued)

Line voltage 500 ... 690 V 3 AC DC link voltage 675 ... 1035 V DC		Motor Modules			
		6SL3320-1TG31-8AA3	6SL3320-1TG32-2AA3	6SL3320-1TG32-6AA3	6SL3320-1TG33-3AA3
Type rating					
• At I_L (50 Hz 690 V) ¹⁾	kW	160	200	250	315
• At I_H (50 Hz 690 V) ¹⁾	kW	132	160	200	250
• At I_L (50 Hz 500 V) ¹⁾	kW	110	132	160	200
• At I_H (50 Hz 500 V) ¹⁾	kW	90	110	132	160
• At I_L (60 Hz 575 V) ²⁾	hp	150	200	250	300
• At I_H (60 Hz 575 V) ²⁾	hp	150	200	200	250
Output current					
• Rated current $I_{rated O}$	A	175	215	260	330
• Base-load current $I_L^{(3)}$	A	171	208	250	320
• Base-load current $I_H^{(4)}$	A	157	192	233	280
• Maximum current $I_{max O}$	A	255	312	375	480
DC link current					
• Rated current $I_{rated DC}$ when supplied via					
- Basic/Smart Line Module	A	210	258	312	396
- Active Line Module	A	189	232	281	356
• Base-load current $I_{L DC}^{(3)}$ when supplied via					
- Basic/Smart Line Module	A	204	251	304	386
- Active Line Module	A	184	226	273	347
• Base-load current $I_{H DC}^{(4)}$ when supplied via					
- Basic/Smart Line Module	A	186	229	277	352
- Active Line Module	A	168	206	250	316
Current demand					
• 24 V DC auxiliary power supply	A	0.9	0.9	0.9	0.9
• 500 V AC	A	1.5	1.5	1.5	1.5
• 690 V AC	A	1.0	1.0	1.0	1.0
DC link capacitance	μF	2800	2800	3900	4200
Pulse frequency ⁵⁾					
• Rated frequency	kHz	1.25	1.25	1.25	1.25
• Pulse frequency, max.					
- Without current derating	kHz	1.25	1.25	1.25	1.25
- With current derating	kHz	7.5	7.5	7.5	7.5
Power loss, max. ⁶⁾					
• At 50 Hz 690 V	kW	2.67	3.09	3.62	4.34
• At 60 Hz 575 V	kW	2.5	2.91	3.38	3.98
Cooling air requirement	m ³ /s	0.36	0.36	0.36	0.36
Sound pressure level L_{pA} (1 m) at 50/60 Hz	dB	69/73	69/73	69/73	69/73
DC link connection DCP, DCN		M10 screw	M10 screw	M10 screw	M10 screw
• Conductor cross section, max. (IEC)	mm ²	2 × 240	2 × 240	2 × 240	2 × 240
Connection for Braking Module DCPA, DCNA ⁷⁾		M6 stud	M6 stud	M6 stud	M6 stud
Connection for dv/dt filter DCPS, DCNS		M8 screw	M8 screw	M8 screw	M8 screw
• Conductor cross section, max. (IEC)	mm ²	1 × 70	1 × 70	1 × 70	1 × 70
Motor connection U2, V2, W2		M10 screw	M10 screw	M10 screw	M10 screw
• Conductor cross section, max. (IEC)	mm ²	2 × 240	2 × 240	2 × 240	2 × 240

For footnotes, see next page.

SINAMICS S120 Chassis Format Converter Units

Air-cooled units

Motor Modules

Technical specifications (continued)

Line voltage 500 ... 690 V 3 AC DC link voltage 675 ... 1035 V DC		Motor Modules			
		6SL3320-1TG31-8AA3	6SL3320-1TG32-2AA3	6SL3320-1TG32-6AA3	6SL3320-1TG33-3AA3
Cable length, max. ⁸⁾					
• Shielded	m	300	300	300	300
• Unshielded	m	450	450	450	450
PE1/GND connection		M10 screw	M10 screw	M10 screw	M10 screw
• Conductor cross section, max. (IEC)	mm ²	2 × 240	2 × 240	2 × 240	2 × 240
PE2/GND connection		M10 screw	M10 screw	M10 screw	M10 screw
• Conductor cross section, max. (IEC)	mm ²	2 × 240	2 × 240	2 × 240	2 × 240
Degree of protection		IP20	IP20	IP20	IP20
Dimensions					
• Width	mm	326	326	326	326
• Height	mm	1533	1533	1533	1533
• Depth	mm	545	545	545	545
Weight, approx.	kg	136	136	136	136
Frame size		GX	GX	GX	GX

¹⁾ Rated output of a typical 6-pole standard induction motor based on I_L or I_H for 500 V or 690 V 3 AC 50 Hz.

²⁾ Rated output of a typical 6-pole standard induction motor based on I_L or I_H for 575 V 3 AC 60 Hz.

³⁾ The base-load current I_L is based on a load cycle of 110 % for 60 s or 150 % for 10 s with a load cycle duration of 300 s.

⁴⁾ The base-load current I_H is based on a duty cycle of 150 % for 60 s or 160 % for 10 s with a duty cycle duration of 300 s.

⁵⁾ Information regarding the correlation between the pulse frequency and maximum output current/output frequency is provided in the Engineering Manual SINAMICS Low Voltage Engineering Manual.

⁶⁾ The specified power loss represents the maximum value at 100% utilization. The value is lower under normal operating conditions.

⁷⁾ The connecting cables are included in the scope of supply of the Braking Module.

⁸⁾ Total of all motor cables and DC link. Longer cable lengths for specific configurations are available on request. For additional information, please refer to the SINAMICS Low Voltage Engineering Manual.

Technical specifications (continued)

Line voltage 500 ... 690 V 3 AC DC link voltage 675 ... 1035 V DC		Motor Modules			
		6SL3320-1TG34-1AA3	6SL3320-1TG34-7AA3	6SL3320-1TG35-8AA3	6SL3320-1TG37-4AA3
Type rating					
• At I_L (50 Hz 690 V) ¹⁾	kW	400	450	560	710
• At I_H (50 Hz 690 V) ¹⁾	kW	315	400	450	630
• At I_L (50 Hz 500 V) ¹⁾	kW	250	315	400	500
• At I_H (50 Hz 500 V) ¹⁾	kW	200	250	315	450
• At I_L (60 Hz 575 V) ²⁾	hp	400	450	600	700
• At I_H (60 Hz 575 V) ²⁾	hp	350	450	500	700
Output current					
• Rated current $I_{rated O}$	A	410	465	575	735
• Base-load current I_L ³⁾	A	400	452	560	710
• Base-load current I_H ⁴⁾	A	367	416	514	657
• Maximum current $I_{max O}$	A	600	678	840	1065
DC link current					
• Rated current $I_{rated DC}$ when supplied via					
- Basic/Smart Line Module	A	492	558	690	882
- Active Line Module	A	443	502	621	794
• Base-load current $I_{L DC}$ ³⁾ when supplied via					
- Basic/Smart Line Module	A	479	544	672	859
- Active Line Module	A	431	489	605	774
• Base-load current $I_{H DC}$ ⁴⁾ when supplied via					
- Basic/Smart Line Module	A	437	496	614	784
- Active Line Module	A	394	446	552	706
Current demand					
• 24 V DC auxiliary power supply	A	1.0	1.0	1.0	1.25
• 500 V AC	A	3.0	3.0	3.0	4.4
• 690 V AC	A	2.1	2.1	2.1	3.1
DC link capacitance	μF	7400	7400	7400	11100
Pulse frequency ⁵⁾					
• Rated frequency	kHz	1.25	1.25	1.25	1.25
• Pulse frequency, max.					
- Without current derating	kHz	1.25	1.25	1.25	1.25
- With current derating	kHz	7.5	7.5	7.5	7.5
Power loss, max. ⁶⁾					
• At 50 Hz 690 V	kW	6.13	6.80	10.3	10.9
• At 60 Hz 575 V	kW	5.71	6.32	9.7	10
Cooling air requirement	m ³ /s	0.78	0.78	0.78	1.08
Sound pressure level L_{pA} (1 m) at 50/60 Hz	dB	70/73	70/73	70/73	71/73
DC link connection DCP, DCN		4 × hole for M10 Busbar	4 × hole for M10 Busbar	4 × hole for M10 Busbar	4 × hole for M10 Busbar
Connection for Braking Module DCPA, DCNA ⁷⁾		M8 stud	M8 stud	M8 stud	M8 stud
Connection for dv/dt filter DCPS, DCNS		M10 screw	M10 screw	M10 screw	2 × M10 screw
• Conductor cross section, max. (IEC)	mm ²	1 × 185	1 × 185	1 × 185	2 × 185
Motor connection U2, V2, W2		2 × M12 screw	2 × M12 screw	2 × M12 screw	3 × M12 screw
• Conductor cross section, max. (IEC)	mm ²	4 × 240	4 × 240	4 × 240	6 × 240

SINAMICS S120 Chassis Format Converter Units

Air-cooled units

Motor Modules

Technical specifications (continued)

Line voltage 500 ... 690 V 3 AC DC link voltage 675 ... 1035 V DC		Motor Modules			
		6SL3320-1TG34-1AA3	6SL3320-1TG34-7AA3	6SL3320-1TG35-8AA3	6SL3320-1TG37-4AA3
Cable length, max. ⁸⁾					
• Shielded	m	300	300	300	300
• Unshielded	m	450	450	450	450
PE1/GND connection		M12 screw	M12 screw	M12 screw	M12 screw
• Conductor cross section, max. (IEC)	mm ²	240	240	240	240
PE2/GND connection		2 × M12 screw	2 × M12 screw	2 × M12 screw	3 × M12 screw
• Conductor cross section, max. (IEC)	mm ²	2 × 240	2 × 240	2 × 240	3 × 240
Degree of protection		IP00	IP00	IP00	IP00
Dimensions					
• Width	mm	503	503	503	704
• Height	mm	1475	1475	1475	1475
• Depth	mm	547	547	547	550
Weight, approx.	kg	290	290	290	450
Frame size		HX	HX	HX	JX

¹⁾ Rated output of a typical 6-pole standard induction motor based on I_L or I_H for 500 V or 690 V 3 AC 50 Hz.

²⁾ Rated output of a typical 6-pole standard induction motor based on I_L or I_H for 575 V 3 AC 60 Hz.

³⁾ The base-load current I_L is based on a load cycle of 110 % for 60 s or 150 % for 10 s with a load cycle duration of 300 s.

⁴⁾ The base-load current I_H is based on a duty cycle of 150 % for 60 s or 160 % for 10 s with a duty cycle duration of 300 s.

⁵⁾ Information regarding the correlation between the pulse frequency and maximum output current/output frequency is provided in the Engineering Manual SINAMICS Low Voltage Engineering Manual.

⁶⁾ The specified power loss represents the maximum value at 100% utilization. The value is lower under normal operating conditions.

⁷⁾ The connecting cables are included in the scope of supply of the Braking Module.

⁸⁾ Total of all motor cables and DC link. Longer cable lengths for specific configurations are available on request. For additional information, please refer to the SINAMICS Low Voltage Engineering Manual.

SINAMICS S120 Chassis Format Converter Units

Air-cooled units

Motor Modules

Technical specifications (continued)

Line voltage 500 ... 690 V 3 AC DC link voltage 675 ... 1035 V DC		Motor Modules			
		6SL3320-1TG38-1AA3	6SL3320-1TG38-8AA3	6SL3320-1TG41-0AA3	6SL3320-1TG41-3AA3
Type rating					
• At I_L (50 Hz 690 V) ¹⁾	kW	800	900	1000	1200
• At I_H (50 Hz 690 V) ¹⁾	kW	710	800	900	1000
• At I_L (50 Hz 500 V) ¹⁾	kW	560	630	710	900
• At I_H (50 Hz 500 V) ¹⁾	kW	500	560	630	800
• At I_L (60 Hz 575 V) ²⁾	hp	800	900	1000	1250
• At I_H (60 Hz 575 V) ²⁾	hp	700	800	900	1000
Output current					
• Rated current $I_{rated O}$	A	810	910	1025	1270
• Base-load current I_L ³⁾	A	790	880	1000	1230
• Base-load current I_H ⁴⁾	A	724	814	917	1136
• Maximum current $I_{max O}$	A	1185	1320	1500	1845
DC link current					
• Rated current $I_{rated DC}$ when supplied via					
- Basic/Smart Line Module	A	972	1092	1230	1524
- Active Line Module	A	875	983	1107	1372
• Base-load current $I_{L DC}$ ³⁾ when supplied via					
- Basic/Smart Line Module	A	947	1064	1199	1485
- Active Line Module	A	853	958	1079	1337
• Base-load current $I_{H DC}$ ⁴⁾ when supplied via					
- Basic/Smart Line Module	A	865	971	1094	1356
- Active Line Module	A	778	874	985	1221
Current demand					
• 24 V DC auxiliary power supply	A	1.25	1.4	1.4	1.4
• 500 V AC	A	4.4	4.4	4.4	4.4
• 690 V AC	A	3.1	3.1	3.1	3.1
DC link capacitance	μF	11100	14400	14400	19200
Pulse frequency ⁵⁾					
• Rated frequency	kHz	1.25	1.25	1.25	1.25
• Pulse frequency, max.					
- Without current derating	kHz	1.25	1.25	1.25	1.25
- With current derating	kHz	7.5	7.5	7.5	7.5
Power loss, max. ⁶⁾					
• At 50 Hz 690 V	kW	11.5	11.7	13.2	16.0
• At 60 Hz 575 V	kW	10.5	10.6	12.0	14.2
Cooling air requirement	m ³ /s	1.08	1.08	1.08	1.08
Sound pressure level L_{pA} (1 m) at 50/60 Hz	dB	71/73	71/73	71/73	71/73
DC link connection DCP, DCN		4 × hole for M10 Busbar	4 × hole for M10 Busbar	4 × hole for M10 Busbar	4 × hole for M10 Busbar
Connection for Braking Module DCPA, DCNA ⁷⁾		M8 stud	M8 stud	M8 stud	M8 stud
Connection for dv/dt filter DCPS, DCNS		2 × M10 screw	2 × M10 screw	2 × M10 screw	2 × M10 screw
• Conductor cross section, max. (IEC)	mm ²	2 × 185	2 × 185	2 × 185	2 × 185
Motor connection U2, V2, W2		3 × M12 screw	3 × M12 screw	3 × M12 screw	3 × M12 screw
• Conductor cross section, max. (IEC)	mm ²	6 × 240	6 × 240	6 × 240	6 × 240

For footnotes, see next page.

SINAMICS S120 Chassis Format Converter Units

Air-cooled units

Motor Modules

Technical specifications (continued)

Line voltage 500 ... 690 V 3 AC DC link voltage 675 ... 1035 V DC		Motor Modules			
		6SL3320-1TG38-1AA3	6SL3320-1TG38-8AA3	6SL3320-1TG41-0AA3	6SL3320-1TG41-3AA3
Cable length, max. ⁸⁾					
• Shielded	m	300	300	300	300
• Unshielded	m	450	450	450	450
PE1/GND connection		M12 screw	M12 screw	M12 screw	M12 screw
• Conductor cross section, max. (IEC)	mm ²	240	240	240	240
PE2/GND connection		3 × M12 screw	3 × M12 screw	3 × M12 screw	3 × M12 screw
• Conductor cross section, max. (IEC)	mm ²	3 × 240	3 × 240	3 × 240	3 × 240
Degree of protection		IP00	IP00	IP00	IP00
Dimensions					
• Width	mm	704	704	704	704
• Height	mm	1475	1475	1475	1475
• Depth	mm	550	550	550	550
Weight, approx.	kg	450	450	450	450
Frame size		JX	JX	JX	JX

¹⁾ Rated output of a typical 6-pole standard induction motor based on I_L or I_H for 500 V or 690 V 3 AC 50 Hz.

²⁾ Rated output of a typical 6-pole standard induction motor based on I_L or I_H for 575 V 3 AC 60 Hz.

³⁾ The base-load current I_L is based on a load cycle of 110 % for 60 s or 150 % for 10 s with a load cycle duration of 300 s.

⁴⁾ The base-load current I_H is based on a duty cycle of 150 % for 60 s or 160 % for 10 s with a duty cycle duration of 300 s.

⁵⁾ Information regarding the correlation between the pulse frequency and maximum output current/output frequency is provided in the Engineering Manual SINAMICS Low Voltage Engineering Manual.

⁶⁾ The specified power loss represents the maximum value at 100% utilization. The value is lower under normal operating conditions.

⁷⁾ The connecting cables are included in the scope of supply of the Braking Module.

⁸⁾ Total of all motor cables and DC link. Longer cable lengths for specific configurations are available on request. For additional information, please refer to the SINAMICS Low Voltage Engineering Manual.

Overview

Power block mounting device for installing and removing the power blocks for the Basic Line Modules, Smart Line Modules, Active Line Modules, Power Modules, and Motor Modules in chassis format.

The mounting device is a mounting aid. It is placed in front of the module and attached to the module. The telescopic rails allow the device to be adjusted to the installation height of the power blocks.

Once the mechanical and electrical connections have been released, the Power block can be removed from the module.

The power block is guided and supported by the guide rails on the handling device.

Selection and ordering data

Description	Article No.
Mounting device for installing and removing power blocks	6SL3766-1FA00-0AA0

SINAMICS S120 Chassis Format Converter Units

Liquid-cooled units

Overview



The SINAMICS S120 liquid-cooled drive units are specifically designed to address the requirements relating to liquid cooling; they are characterized by their high power density and optimized footprint. Liquid cooling dissipates heat much more efficiently than air cooling systems. As a result, liquid-cooled units are much more compact than air-cooled units with the same power rating. Since the heat losses generated by the electronic components are almost completely dissipated by the liquid coolant, only very small cooling fans are required. This means that the devices are quiet in operation. Due to their compact dimensions and almost negligible cooling air requirement, liquid-cooled units are the preferred solution wherever installation space is restricted and/or the ambient operating conditions are rough.

Control cabinets with liquid cooling are easy to implement as sealed units with degrees of protection of IP55.

The product portfolio includes the following liquid-cooled SINAMICS S120 built-in units:

- Power Modules
- Basic Line Modules
- Active Line Modules
- Active Interface Modules
- Motor Modules

The associated system components such as line reactors, motor reactors, dv/dt filters plus VPL and sine-wave filters are air-cooled. Active Interface Modules are available in air-cooled and liquid-cooled versions.

Highlights of the liquid-cooled units

- Up to a 60 % smaller footprint than air-cooled drive converters
- All main components such as power semiconductors, DC link capacitors and balancing resistors are cooled by the cooling circuit
- Only a low flow rate is required
- Uniform pressure drop of 0.7 bar
- Automatic protective functions
- Nickel-plated busbars
- Low noise
- Compatible with all components and functions and tools of the SINAMICS system family
- The power rating can be extended by connecting units in parallel
- No equipment fans

Cabinet units in liquid-cooled version

Liquid-cooled SINAMICS S120 drive units are also available as cabinet units, including cooling system. [See section SINAMICS S120 Cabinet Modules → Liquid-cooled units.](#)

SINAMICS S120 Chassis Format Converter Units

Liquid-cooled units

Overview (continued)

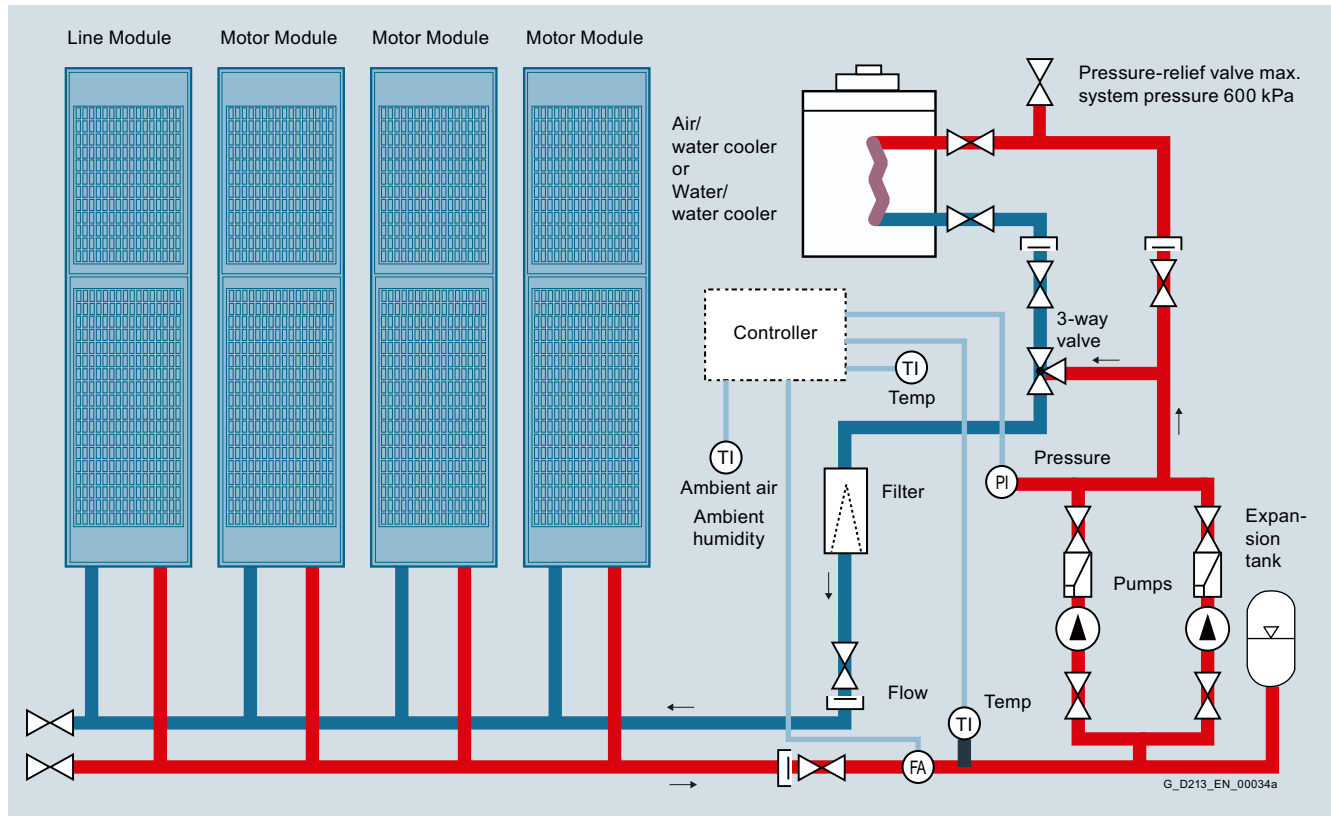

Example of a drive line-up with SINAMICS S120 liquid-cooled units

Technical specifications

General technical specifications

Unless clearly specified otherwise, the following technical data are valid for all the following components of the liquid-cooled SINAMICS S120 drive system in the chassis format.

Electrical specifications	
Rated voltages	380 ... 480 V 3 AC, $\pm 10\%$ ($-15\% < 1$ min) 500 ... 690 V 3 AC, $\pm 10\%$ ($-15\% < 1$ min)
Line supply types	Grounded TN/TT systems and non-grounded IT systems
Line frequency	47 ... 63 Hz
Overvoltage category	III to EN 61800-5-1
Electronics power supply	24 V DC, -15% $+20\%$ implemented as PELV circuit in accordance with EN 61800-5-1 Ground = negative pole grounded via the electronics
Rated short-circuit current per IEC, in conjunction with the specified fuses or circuit breakers	
Rated power	
• 1.1 ... 447 kW	65 kA
• 448 ... 671 kW	84 kA
• 672 ... 1193 kW	170 kA
• > 1194 kW	200 kA
Rated short-circuit current SCCR (Short Circuit Current Rating) according to UL508C (up to 600 V), in conjunction with the specified fuses or circuit breakers	
Rated power	
• 1.1 ... 447 kW	65 kA
• 448 ... 671 kW	84 kA
• 672 ... 1193 kW	170 kA
• > 1194 kW	200 kA

SINAMICS S120 Chassis Format Converter Units

Liquid-cooled units

Technical specifications (continued)

Electrical specifications			
Control method	Vector/servo control with and without encoder or V/f control		
Fixed speeds	15 fixed speeds plus 1 minimum speed, parameterizable (in the default setting, 3 fixed setpoints plus 1 minimum speed are selectable using terminal block/PROFIBUS/PROFINET)		
Skippable speed ranges	4, parameterizable		
Setpoint resolution	0.001 rpm digital (14 bits + sign) 12 bits analog		
Braking operation	With Active Line Modules, four-quadrant operation as standard (energy recovery). With Basic Line Modules, two-quadrant operation as standard, braking by means of an optional braking chopper, or alternatively by a Motor Module.		
Mechanical specifications			
Degree of protection	IP00 (IP20, without taking into account the connecting busbars)		
Protection class	I acc. to EN 61800-5-1		
Touch protection	EN 50274 / BGV A3 when used for the intended purpose		
Cooling method	Liquid cooling with integrated heat exchanger in aluminum or stainless steel version		
Ambient conditions	Storage ¹⁾	Transport ¹⁾	Operation
Ambient temperature (air)	-25 ... +55 °C Class 1K4 acc. to EN 60721-3-1	-25 ... +70 °C Class 2K4 acc. to EN 60721-3-2	Line-side components, Power Modules, Line Modules and Motor Modules: 0 ... 45 °C without derating, > 45 ... 50 °C, see derating characteristics Control Units, supplementary system components, and Sensor Modules: 0 ... 55 °C (for operation in control cabinet) DC link components and motor-side components: 0 ... 55 °C
Relative humidity Condensation, splashwater, and ice formation not permitted (EN 60204, Part 1)	5 ... 95 % Class 1K4 acc. to EN 60721-3-1	Max. 95 % at 40 °C Class 2K4 acc. to EN 60721-3-2	5 ... 95 % Class 3K3 acc. to EN 60721-3-3
Environmental class/harmful chemical substances	Class 1C2 acc. to EN 60721-3-1	Class 2C2 acc. to EN 60721-3-2	Class 3C2 acc. to EN 60721-3-3
Organic/biological influences	Class 1B1 acc. to EN 60721-3-1	Class 2B1 acc. to EN 60721-3-2	Class 3B1 acc. to EN 60721-3-3
Degree of pollution	2 according to EN 61800-5-1		
Installation altitude	Up to 2000 m above sea level without derating, > 2000 m above sea level, refer to the derating data		
Mechanical stability	Storage ¹⁾	Transport ¹⁾	Operation
Vibratory load		Class 2M2 acc. to EN 60721-3-2	Test values acc. to EN 60068-2-6 test Fc: • 10 ... 58 Hz with constant deflection 0.075 mm • 58 ... 150 Hz with constant acceleration 9.81 m/s ² (1 × g)
Shock load		Class 2M2 acc. to EN 60721-3-2	Test values according to EN 60068-2-27 test Ea: 98 m/s ² (10 × g)/20 ms
Compliance with standards			
Conformances/approvals, according to	CE (EMC Directive No. 2004/108/EC, Low Voltage Directive No. 2006/95/EC and Machinery Directive 2006/42/EC for functional safety) C-Tick cULus (only for devices connected to line supply voltages 380 ... 480 V 3 AC and 500 ... 600 V 3 AC, see Appendix)		
Radio interference suppression	SINAMICS drive converter systems are not designed for connection to the public grid (first environment). Radio interference suppression is compliant with the EMC product standard for variable-speed drives EN 61800-3, "Second environment" (Industrial line supplies). EMC disturbances can occur when connected to the public power networks.		

Deviations from the specified class are underlined.

¹⁾ In transport packaging.

Technical specifications (continued)

Cooling circuit and coolant quality

The following tables and sections describe the quality requirements of the coolant used in the liquid-cooled SINAMICS S120 drive system in chassis format.

Cooling circuit	
• System pressure with reference to atmospheric pressure, max.	600 kPa
• Pressure drop at rated volumetric flow	70 kPa
• Recommended pressure range	80 ... 200 kPa
• Inlet temperature of liquid coolant	Dependent on ambient temperature, no condensation permitted 0 ... 45 °C without derating >45 ... 50 °C, see derating data Anti-freeze essential for temperature range between 0 °C and 5 °C
Coolant quality	
• Coolant basis for aluminum heat sinks	Deionized water with reduced electrical conductivity according to ISO 3696, quality 3
- Electrical conductivity	<5 µS/cm (0.5 mS/m)
- pH value	5 ... 7.5
- Components that can be oxidized as oxygen content	<0.4 mg/l
- Residue after vaporization and drying at 110 °C	<2 mg/kg
• Coolant basis for stainless steel heat sinks	Filtered drinking water
- Electrical conductivity	<2000 µS/cm
- pH value	6.5 ... 9
- Chloride ions	<200 mg/l
- Sulfate ions	<240 mg/l
- Nitrate ions	<50 mg/l
- Total hardness	<1.7 mmol/l
- Dissolved substances	<340 mg/l
- Size of entrained particles	<100 µm
The coolant definition specified here should only be considered as recommendation. For units that have been shipped, the information and data provided in the equipment manual supplied should be observed!	

Antifreeze

Antifreeze	Antifrogen N	Antifrogen L	Varidos FSK
Manufacturer	Clariant	Clariant	Nalco
Chemical base	Monoethylene glycol	Propylene glycol	Monoethylene glycol
Minimum concentration	20 %	25 %	25 %
Anti-freeze agent with minimum concentration	-10 °C	-10 °C	-10 °C
Maximum concentration	45 %	48 %	45 %
Anti-freeze agent with maximum concentration	-30 °C	-30 °C	-30 °C
Inhibitor content	Contains inhibitors with nitrites	Contains inhibitors that are free of nitrates, amines, borates, and phosphate	Contains inhibitors that are free of nitrates, amines, borates, and phosphate
Biocide action with a concentration of	>20 %	>30 %	>30 %

Biocides prevent corrosion that is caused by slime-forming, corrosive or iron-depositing bacteria. These can occur in closed cooling circuits with low water hardness and in open cooling circuits. Biocides must always be selected according to the relevant bacterial risks. Compatibility with inhibitors or antifreeze used with them must be checked on a case-by-case basis.

SINAMICS S120 Chassis Format Converter Units

Liquid-cooled units

Protection against condensation

With liquid-cooled units, warm air can condense on the cold surfaces of heat sinks, pipes and hoses. This condensation depends on the air humidity and the temperature difference between the ambient air and the coolant.

The water which is produced as a result of condensation can cause corrosion as well as electrical damage such as creepage shorts and flashovers. As the SINAMICS units cannot prevent condensation if it is caused by the prevailing climatic conditions, any potential risk of condensation must be prevented by appropriate engineering or by precautionary measures implemented by the customer. These measures include the following:

- a fixed coolant temperature that has been adjusted to the expected air humidity or ambient temperature ensures that critical differences between the coolant and ambient air temperatures do not develop or
- temperature regulation of the coolant as a function of the ambient air temperature

The temperature at which water vapor contained in the air condenses into water is known as the dew point. To prevent condensation reliably, the coolant temperature must always be higher than the dew point.

The table below specifies the dew point as a function of room temperature T and relative air humidity Φ for an atmospheric pressure of 100 kPa (1 bar). This corresponds to an installation altitude of 0 to approximately 500 m above sea level. Since the dew point drops as the air pressure decreases, the dew point values at higher installation altitudes are lower than the specified table values. It is therefore the safest approach to engineer the coolant temperature according to the table values for an installation altitude of zero.

A detailed description of the cooling circuits and the recommended coolant is given in the SINAMICS Low Voltage Engineering Manual.

Ambient temperature T	Relative air humidity Φ										
	20 %	30 %	40 %	50 %	60 %	70 %	80 %	85 %	90 %	95 %	100 %
10 °C	<0 °C	<0 °C	<0 °C	0.2 °C	2.7 °C	4.8 °C	6.7 °C	7.6 °C	8.4 °C	9.2 °C	10 °C
20 °C	<0 °C	2 °C	6 °C	9.3 °C	12 °C	14.3 °C	16.4 °C	17.4 °C	18.3 °C	19.1 °C	20 °C
25 °C	0.6 °C	6.3 °C	10.5 °C	13.8 °C	16.7 °C	19.1 °C	21.2 °C	22.2 °C	23.2 °C	24.1 °C	24.9 °C
30 °C	4.7 °C	10.5 °C	14.9 °C	18.4 °C	21.3 °C	23.8 °C	26.1 °C	27.1 °C	28.1 °C	29 °C	29.9 °C
35 °C	8.7 °C	14.8 °C	19.3 °C	22.9 °C	26 °C	28.6 °C	30.9 °C	32 °C	33 °C	34 °C	34.9 °C
40 °C	12.8 °C	19.1 °C	23.7 °C	27.5 °C	30.6 °C	33.4 °C	35.8 °C	36.9 °C	37.9 °C	38.9 °C	39.9 °C
45 °C	16.8 °C	23.3 °C	28.2 °C	32 °C	35.3 °C	38.1 °C	40.6 °C	41.8 °C	42.9 °C	43.9 °C	44.9 °C
50 °C	20.8 °C	27.5 °C	32.6 °C	36.6 °C	40 °C	42.9 °C	45.5 °C	46.6 °C	47.8 °C	48.9 °C	49.9 °C

Characteristic curves

Pressure drop

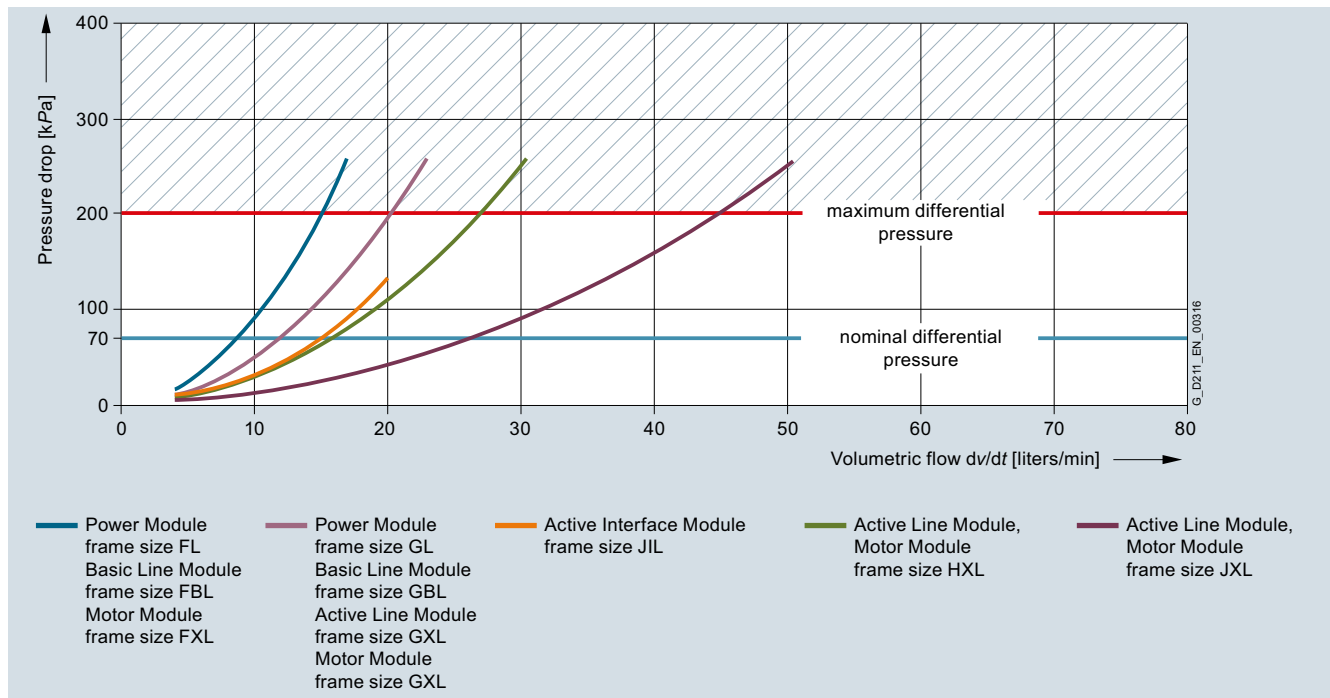

Pressure drop for liquid-cooled built-in units in chassis format

The pressure drop characteristics are valid for water. If anti-freeze is used, the characteristics typically shift to the left.

For further information, please refer to the [SINAMICS Low Voltage Engineering Manual](#).

Characteristic curves (continued)

Derating

Liquid-cooled SINAMICS S120 chassis format units are rated for an ambient temperature of 45 °C and installation altitudes up to 2000 m above sea level. At ambient temperatures >45 °C, the output current must be reduced. Ambient temperatures above 50 °C are not permissible. At installation altitudes >2000 m above sea level, it must be taken into account that the air pressure, and therefore air density, decreases as the height increases. As a consequence, the cooling efficiency and the insulation capacity of the air also decrease.

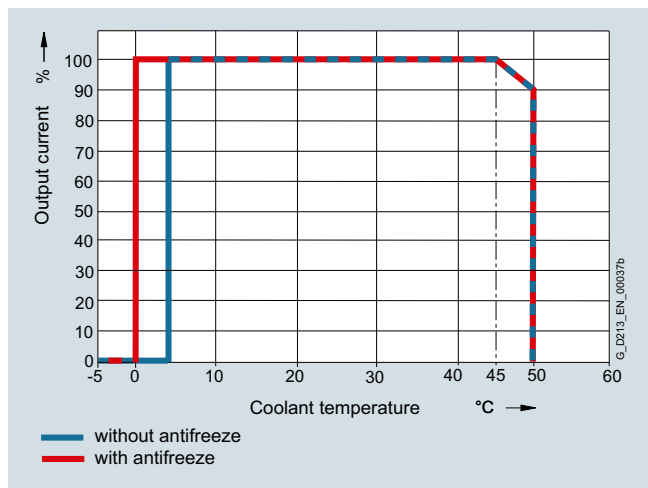

Current derating as a function of the temperature of the cooling liquid ¹⁾

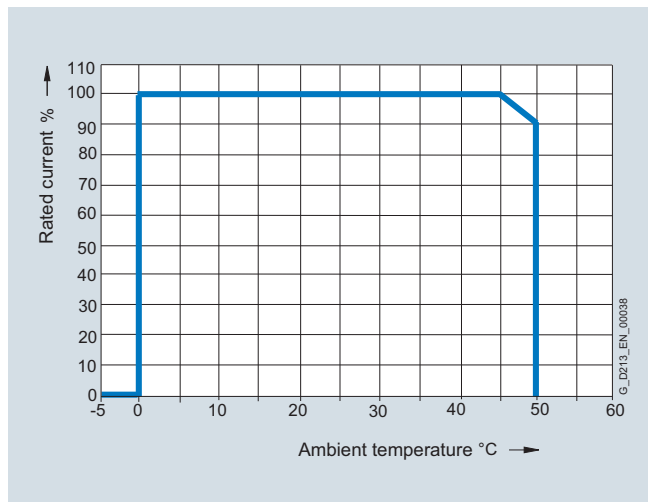

Current derating as a function of ambient temperature ¹⁾

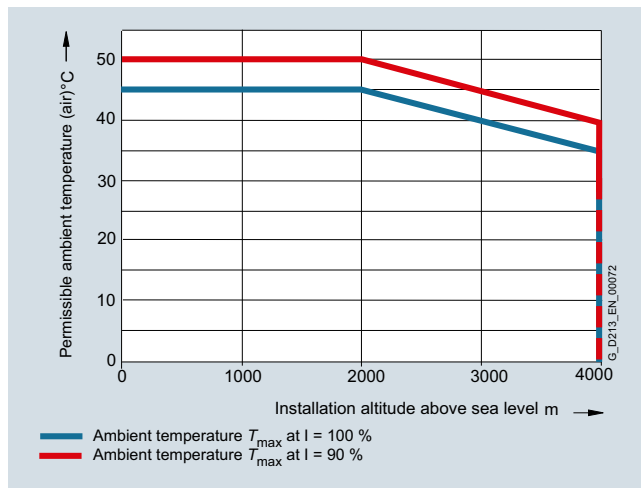

Permissible ambient temperature as a function of installation altitude

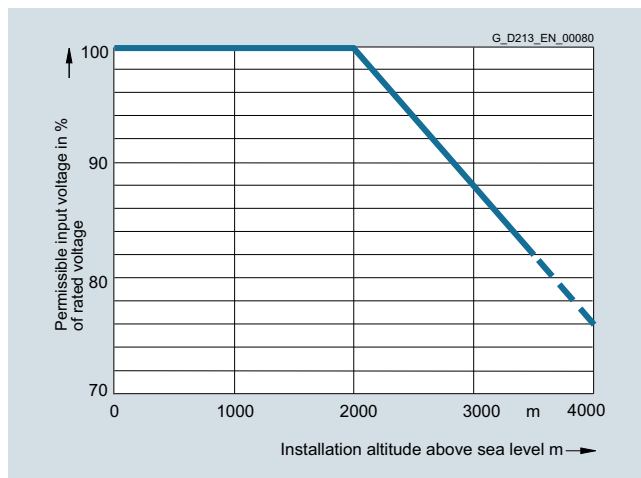

Voltage derating as a function of installation altitude

¹⁾ The factors of the two curves must not be multiplied. The highest value in each case must be assumed for the purposes of calculation, so that the derating factor in the worst-case scenario is 0.9.

SINAMICS S120 Chassis Format Converter Units

Liquid-cooled units

Characteristic curves (continued)

Current derating for Power Modules and Motor Modules in chassis format as a function of the pulse frequency

To reduce motor noise or to increase output frequency, the pulse frequency can be increased relative to the factory setting (1.25 kHz or 2 kHz). When the pulse frequency is increased, the derating factor of the output current must be taken into account. This derating factor must be applied to the currents specified in the technical specifications.

For additional information, please refer to the [SINAMICS Low Voltage Engineering Manual](#).

The following tables list the rated output currents of the SINAMICS S120 Power Modules and Motor Modules with pulse frequency set in the factory as well as the current derating factors (permissible output currents referred to the rated output current) for higher pulse frequencies.

Derating factor of the output current as a function of the pulse frequency for units with a rated pulse frequency of 2 kHz

Power Module Motor Module	Type rating at 400 V kW	Output current at 2 kHz A	Derating factor at pulse frequency				
			2.5 kHz	4 kHz	5 kHz	7.5 kHz	8 kHz
380 ... 480 V 3 AC							
1TE32-1AA3	110	210	95 %	82 %	74 %	54 %	50 %
1TE32-6AA3	132	260	95 %	83 %	74 %	54 %	50 %
1TE33-1AA3	160	310	97 %	88 %	78 %	54 %	50 %
1TE35-0AA3	250	490	94 %	78 %	71 %	53 %	50 %
1TE41-4AS3 ¹⁾	800	1330	88 %	55 %	–	–	–

Derating factor of the output current as a function of the pulse frequency for units with a rated pulse frequency of 1.25 kHz

Motor Module	Type rating at 400 V or 690 V kW	Output current at 1.25 kHz A	Derating factor at pulse frequency				
			2 kHz	2.5 kHz	4 kHz	5 kHz	7.5 kHz
380 ... 480 V 3 AC							
1TE36-1AA3	315	605	83 %	72 %	64 %	60 %	40 %
1TE37-5AA3	400	745	83 %	72 %	64 %	60 %	40 %
1TE38-4AA3	450	840	87 %	79 %	64 %	60 %	40 %
1TE41-0AA3	560	985	92 %	87 %	70 %	60 %	50 %
1TE41-2AA3	710	1260	92 %	87 %	70 %	60 %	50 %
1TE41-4AA3	800	1405	97 %	95 %	74 %	60 %	50 %
500 ... 690 V 3 AC							
1TG31-0AA3	90	100	92 %	88 %	71 %	60 %	40 %
1TG31-5AA3	132	150	90 %	84 %	66 %	55 %	35 %
1TG32-2AA3	200	215	92 %	87 %	70 %	60 %	40 %
1TG33-3AA3	315	330	89 %	82 %	65 %	55 %	40 %
1TG34-7AA3	450	465	92 %	87 %	67 %	55 %	35 %
1TG35-8AA3	560	575	91 %	85 %	64 %	50 %	35 %
1TG37-4AA3	710	735	84 %	74 %	53 %	40 %	25 %
1TG38-0AA3 ²⁾	800	810	82 %	71 %	52 %	40 %	25 %
1TG38-1AA3	800	810	97 %	95 %	71 %	55 %	35 %
1TG41-0AA3	1000	1025	91 %	86 %	64 %	50 %	30 %
1TG41-3AA3	1200	1270	87 %	79 %	55 %	40 %	25 %
1TG41-6AA3	1500	1560	87 %	79 %	55 %	40 %	25 %

The following tables list the maximum achievable output frequency as a function of the pulse frequency:

Maximum output frequencies achieved by increasing the pulse frequency in Vector mode

Pulse frequency	Max. achievable output frequency
1.25 kHz	100 Hz
2 kHz	160 Hz
2.5 kHz	200 Hz
4 kHz	320 Hz
5 kHz	400 Hz

Maximum output frequencies achieved by increasing the pulse frequency in Servo mode

Pulse frequency	Max. achievable output frequency
2 kHz	300 Hz
4 kHz	300/550 Hz ³⁾

¹⁾ This Motor Module has been specifically designed for loads demanding a high dynamic performance. The derating factor k_{IGBT} and the derating characteristics can be ignored (see section "Duty cycles" in the SINAMICS Low Voltage Engineering Manual).

²⁾ The Motor Module 6SL3325-1TG38-0AA3 is optimized for low overload; with an increased pulse frequency, the derating factor is higher than for the Motor Module 6SL3325-1TG38-1AA3.

³⁾ Higher frequencies on request.

Characteristic curves (continued)

Overload capability

Liquid-cooled SINAMICS S120 units have an overload reserve, e.g. to handle breakaway torques. If larger surge loads occur, this must be taken into account in the configuration. For drives with overload requirements, the appropriate base load current must, therefore, be used as a basis for the required load.

The permissible overload levels are valid under the prerequisite that the drive units are operated with their base-load current before and after the overload condition based on a duty cycle duration of 300 s.

For temporary, periodic duty cycles with high variations of load within the duty cycle, the relevant sections of the SINAMICS Low Voltage Engineering Manual must be observed.

Power Modules and Motor Modules

The base-load current for a low overload I_L is the basis for a duty cycle of 110 % for 60 s or 150 % for 10 s.

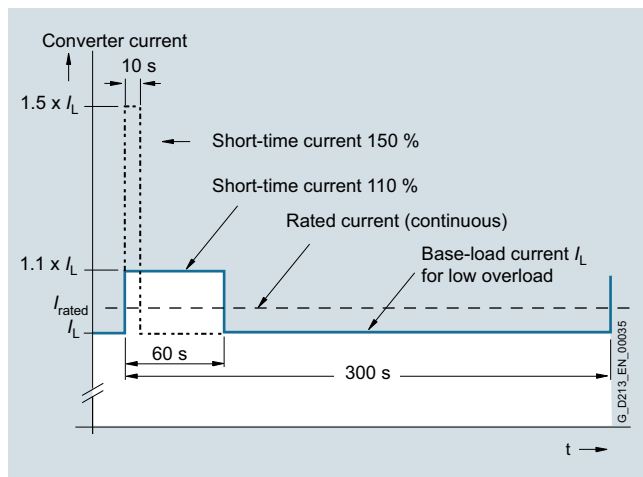

Low overload

The base-load current I_H for a high overload is based on a load cycle of 150 % for 60 s or 160 % for 10 s.

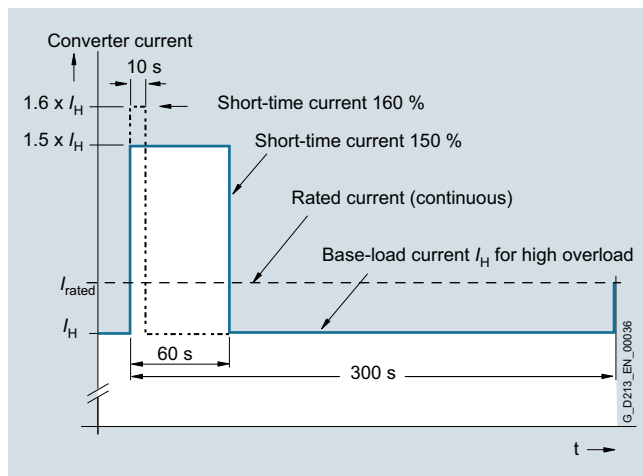

High overload

Line Modules

The base-load current for a high overload I_{HDC} is the basis for a duty cycle of 150 % for 60 s or I_{maxDC} for 5 s.

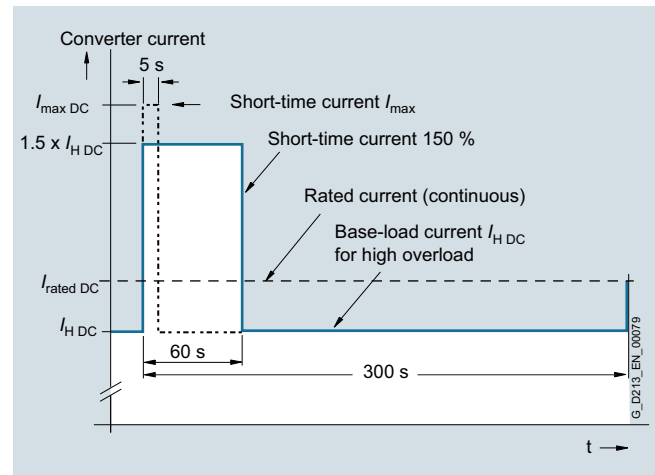

High overload

SINAMICS S120 Chassis Format Converter Units

Liquid-cooled units

Power Modules

Overview



The Power Module comprises a line rectifier, a DC link and an inverter to supply the motor.

Power Modules are designed for drives that are not capable of regenerating energy to the mains supply. If the motor produces energy during braking, a Braking Module with braking resistors will be required.

Liquid-cooled Power Modules are especially suitable for applications where installation space is restricted and environmental conditions are harsh. Liquid cooling ensures efficient heat dissipation.

Power Modules in the chassis format can be connected to grounded TN/TT systems and non-grounded IT systems.

Design

The liquid-cooled Power Modules have the following interfaces as standard:

- 1 line supply connection
- 1 motor connection
- 1 connection for the 24 V DC electronics power supply
- 1 DC link connection
- 3 DRIVE-CLiQ sockets
- 1 temperature sensor input (KTY84-130, PTC or Pt100)
- 1 connection for Safe Brake Adapter
- 1 connection for Safety Integrated
- 2 PE connections
- 2 coolant connections

The CU310-2 Control Unit can be integrated into the liquid-cooled Power Modules.

The status of the Power Modules is indicated via three LEDs.

The scope of supply of the Power Modules includes:

- 1 DRIVE-CLiQ cable for connection to the Control Unit
- 2 seals for coolant connections
- 1 set of warning labels in 30 languages (BG, CN, CZ, DE, DK, EE, ES, FI, FR, GB, GR, HU, IE, IS, IT, JP, KR, LT, LV, MT, NL, NO, PL, PT, RO, RU, SE, SI, SK, TR)

¹⁾ Recommended components for installing a flow control as condensation protection; manufactured by: Siemens Building Technologies.

Selection and ordering data

Type rating at 400 V kW	Rated output current A	Power Module Article No.
Line voltage 380 ... 480 V 3 AC		
110	210	6SL3315-1TE32-1AA3
132	260	6SL3315-1TE32-6AA3
160	310	6SL3315-1TE33-1AA3
250	490	6SL3315-1TE35-0AA3
Description		Article No.
Accessories		
3-way valve ¹⁾		VXF41.../VXG41...
Actuator for 3-way valve ¹⁾		
• 230 V 1 AC		SAX31...
• 24 V AC/DC		SAX61.../SAX81...
Accessories for re-ordering		
Dust protection blanking plugs (50 units) For DRIVE-CLiQ port		6SL3066-4CA00-0AA0

For additional information, refer to the manual.

For line-side and motor-side components, see System components.

Integration

The Power Modules communicate with the higher-level control module via DRIVE-CLiQ. The Control Unit in this case could be a CU310-2, CU320-2 or a SIMOTION D Control Unit. An external 24 V DC power supply is required to operate liquid-cooled Power Modules.

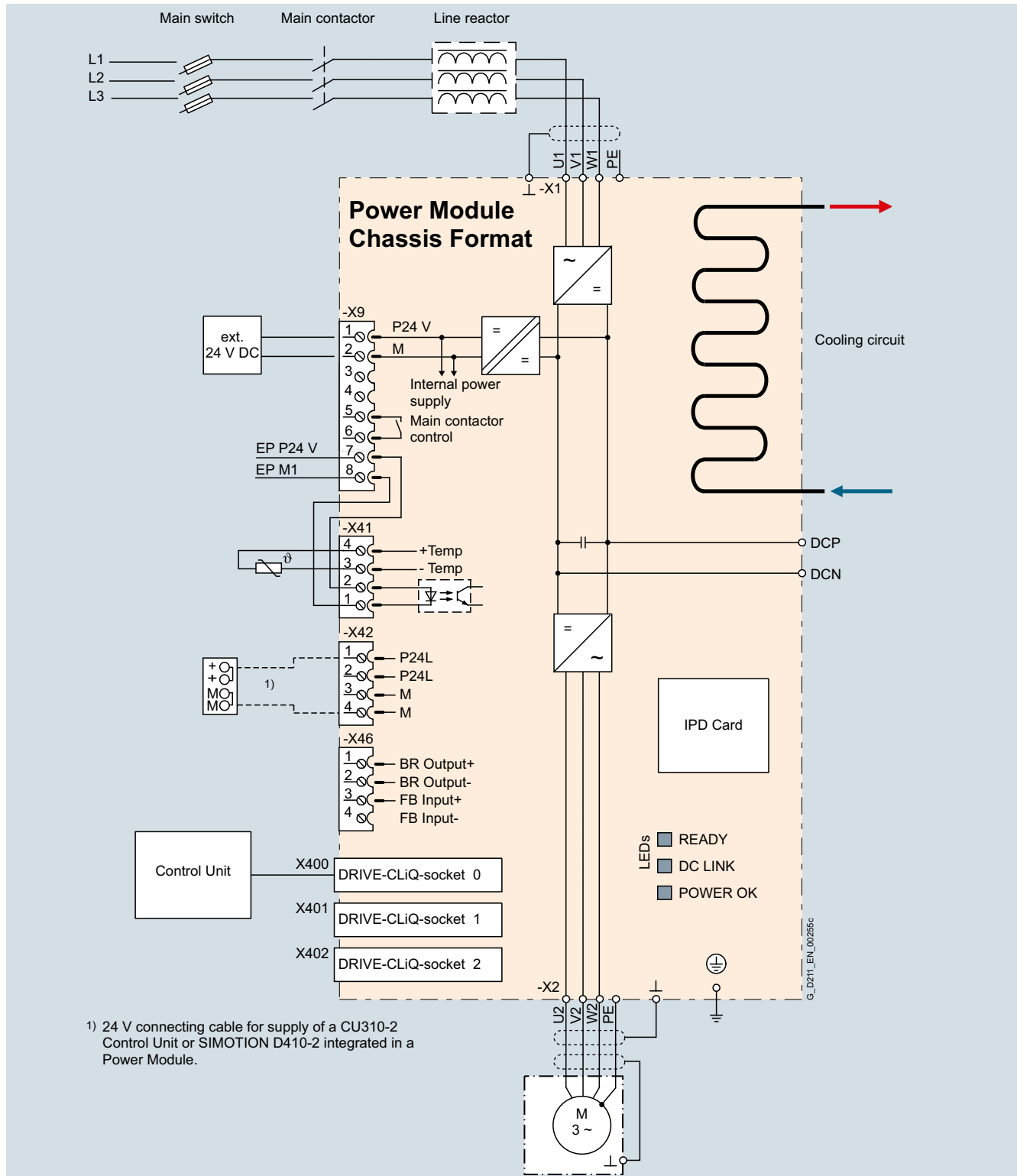

Connection example, liquid-cooled Power Module in the chassis format

Note:

The integrated 24 V power supply at connector X42 can have a maximum load of 2 A. When the Control Unit is supplied from the

integrated power supply, the total load of the digital outputs must be carefully observed to ensure that the 2 A is not exceeded.

SINAMICS S120 Chassis Format Converter Units

Liquid-cooled units

Power Modules

Technical specifications

General technical specifications

Electrical specifications	
Line connection voltage Up to 2000 m above sea level	380 ... 480 V 3 AC $\pm 10\%$ (-15 % < 1 min)
Line power factor for a 3 AC line supply voltage and rated power	
• Basic fundamental ($\cos \varphi_1$)	>0.96
• Total (λ)	0.75 ... 0.93
Efficiency	> 98 %
DC link voltage, approx.	1.35 × line voltage
Output voltage, approx.	0 ... $0.97 \times U_{line}$
Output frequency ¹⁾	
• Control type Servo	0 ... 550 Hz
• Control type Vector	0 ... 550 Hz
• Control mode V/f	0 ... 550 Hz
Electronics power supply	24 V DC -15 %/+20 %
Main contactor control	
• Terminal block -X9/5-6	240 V AC, max. 8 A 30 V DC, max. 1 A
Safety Integrated	Safety Integrity Level 2 (SIL2) acc. to IEC 61508, Performance Level d (PLd) acc. to EN ISO 13849-1 and Control Category 3 acc. to EN ISO 13849-1.

¹⁾ Please note:

- The correlation between maximum output frequency, pulse frequency and current derating. Higher output frequencies on request.
- The correlation between the minimum output frequency and permissible output current (current derating). [Information is provided in the SINAMICS Low Voltage Engineering Manual.](#)

SINAMICS S120 Chassis Format Converter Units

Liquid-cooled units

Power Modules

Technical specifications (continued)

Line voltage 380 V ... 480 V 3 AC		Power Modules			
		6SL3315-1TE32-1AA3	6SL3315-1TE32-6AA3	6SL3315-1TE33-1AA3	6SL3315-1TE35-0AA3
Type rating					
• At I_L (50 Hz 400 V) ¹⁾	kW	110	132	160	250
• At I_H (50 Hz 400 V) ¹⁾	kW	90	110	132	200
• At I_L (60 Hz 460 V) ²⁾	hp	150	200	250	400
• At I_H (60 Hz 460 V) ²⁾	hp	150	200	200	350
Output current					
• Rated current $I_{rated O}$	A	210	260	310	490
• Base-load current $I_L^{(3)}$	A	205	250	302	477
• Base-load current $I_H^{(4)}$	A	178	233	277	438
• Max. output current $I_{max O}$	A	307	375	453	715
Input current					
• Rated current $I_{rated I}$	A	230	285	340	540
• Maximum current $I_{max I}$	A	336	411	496	788
Current demand					
• 24 V DC auxiliary power supply	A	1.4	1.4	1.5	1.5
Pulse frequency ⁵⁾					
• Rated frequency	kHz	2	2	2	2
• Pulse frequency, max.					
- Without current derating	kHz	2	2	2	2
- With current derating	kHz	8	8	8	8
Power loss, at 50 Hz 400 V ⁶⁾					
• Dissipated to coolant	kW	2.36	2.97	3.31	5.29
• Dissipated to ambient air	kW	0.06	0.07	0.09	0.14
• Total	kW	2.42	3.04	3.4	5.43
Coolant volume flow ⁷⁾					
	l/min	9	9	12	12
Liquid volume					
of the integrated heat exchanger	dm ³	0.52	0.52	0.88	0.88
Pressure drop, typ. ⁸⁾					
for volume flow	Pa	70000	70000	70000	70000
Heat exchanger material					
		Stainless steel	Stainless steel	Stainless steel	Stainless steel
Sound pressure level L_{pA}					
(1 m) at 50/60 Hz	dB	52	52	52	52
Line connection					
U1, V1, W1		Hole for M12	Hole for M12	Hole for M12	Hole for M12
• Conductor cross section, max. (IEC)	mm ²	2 × 95	2 × 95	2 × 240	2 × 240
DC link connection					
DCP, DCN		Hole for M12	Hole for M12	Hole for M12	Hole for M12
• Conductor cross section, max. (IEC)	mm ²	2 × 95	2 × 95	2 × 240	2 × 240
Motor connection					
U2/T1, V2/T2, W2/T3		Hole for M12	Hole for M12	2 × hole for M12	2 × hole for M12
• Conductor cross section, max. (IEC)	mm ²	2 × 95	2 × 95	2 × 240	2 × 240
Cable length, max. ⁹⁾					
• Shielded	m	300	300	300	300
• Unshielded	m	450	450	450	450
PE/GND connection					
• Conductor cross section, max. (IEC)	mm ²	2 × hole for M12 2 × 95	2 × hole for M12 2 × 95	2 × hole for M12 2 × 240	2 × hole for M12 2 × 240
Dimensions					
• Width	mm	265	265	265	265
• Height	mm	836	836	983	983
• Depth	mm	549	549	549	549
Weight, approx.					
	kg	77	77	108	108
Frame size					
		FL	FL	GL	GL
Minimum short-circuit current ¹⁰⁾					
	A	3000	3600	4400	8000

¹⁾ Rated output of a typical 6-pole standard induction motor based on I_L or I_H for 400 V 3 AC 50 Hz.

²⁾ Rated output of a typical 6-pole standard induction motor based on I_L or I_H for 460 V 3 AC 60 Hz.

³⁾ The base-load current I_L is based on a load cycle of 110 % for 60 s or 150 % for 10 s with a load cycle duration of 300 s.

⁴⁾ The base-load current I_H is based on a duty cycle of 150 % for 60 s or 160 % for 10 s with a duty cycle duration of 300 s.

⁵⁾ Information regarding the correlation between the pulse frequency and maximum output current/output frequency is provided in the SINAMICS Low Voltage Engineering Manual.

⁶⁾ The specified power loss represents the maximum value at 100% utilization. The value is lower under normal operating conditions. To ensure safe dissipation of the minor power loss released to the ambient air, it is important to follow the instructions pertaining to control cabinet installation in the SINAMICS Low Voltage Engineering Manual.

⁷⁾ The value applies to coolants comprising water and a mixture of water and anti-freeze agent.

⁸⁾ The value is valid for water as coolant. Additional information and notes on other coolants is provided in the SINAMICS Low Voltage Engineering Manual.

⁹⁾ Longer cable lengths for specific configurations are available on request. For additional information, please refer to the SINAMICS Low Voltage Engineering Manual.

¹⁰⁾ Current required for reliably triggering protective devices.

SINAMICS S120 Chassis Format Converter Units

Liquid-cooled units

Basic Line Modules

Overview



Basic Line Modules are used for applications where energy is not fed back into the line supply or where energy is exchanged in the DC link between axes operating in the motor and generator modes. The connected Motor Modules are pre-charged via the thyristor gate control. Basic Line Modules are designed for connection to grounded TN/TT and non-grounded IT supply systems.

Liquid-cooled Basic Line Modules are especially suitable for applications where installation space is restricted and environmental conditions are harsh. Liquid cooling ensures efficient heat dissipation.

Design

The liquid-cooled Basic Line Modules have the following interfaces as standard:

- 1 line supply connection
- 1 connection for the 24 V DC electronics power supply
- 1 DC link connection (DCP, DCN) for supplying the connected Motor Modules
- 3 DRIVE-CLiQ sockets
- 1 temperature sensor input (KTY84-130, PTC or Pt100)
- 1 PE connection
- 2 coolant connections

The status of the Basic Line Modules is indicated via three LEDs.

The scope of supply of the Power Modules includes:

- 1 DRIVE-CLiQ cable for connection to the Control Unit
- 2 seals for coolant connections
- 1 set of warning labels in 30 languages (BG, CN, CZ, DE, DK, EE, ES, FI, FR, GB, GR, HU, IE, IS, IT, JP, KR, LT, LV, MT, NL, NO, PL, PT, RO, RU, SE, SI, SK, TR)

Selection and ordering data

Rated power at 400 V or 690 V kW	Rated DC link current A	Basic Line Module Article No.
Line voltage 380 ... 480 V 3 AC		
360	740	6SL3335-1TE37-4AA3
600	1220	6SL3335-1TE41-2AA3
830	1730	6SL3335-1TE41-7AA3
Line voltage 500 ... 690 V 3 AC		
355	420	6SL3335-1TG34-2AA3
630	730	6SL3335-1TG37-3AA3
1100	1300	6SL3335-1TG41-3AA3
1370	1650	6SL3335-1TG41-7AA3
Description		Article No.
<i>Accessories</i>		
3-way valve ¹⁾		VXF41.../VXG41...
Actuator for 3-way valve ¹⁾		
• 230 V 1 AC		SAX31...
• 24 V AC/DC		SAX61.../SAX81...
<i>Accessories for re-ordering</i>		
Dust protection blanking plugs (50 units)		6SL3066-4CA00-0AA0
For DRIVE-CLiQ port		

For line-side components, see System components.

¹⁾ Recommended components for installing a flow control as condensation protection; manufactured by Siemens Building Technologies.

Integration

The liquid-cooled Basic Line Modules communicate with the higher-level control module via DRIVE-CLiQ. The control module in this case can be a CU320-2 or a SIMOTION D Control Unit. An external 24 V DC power supply is required to operate liquid-cooled Basic Line Modules.

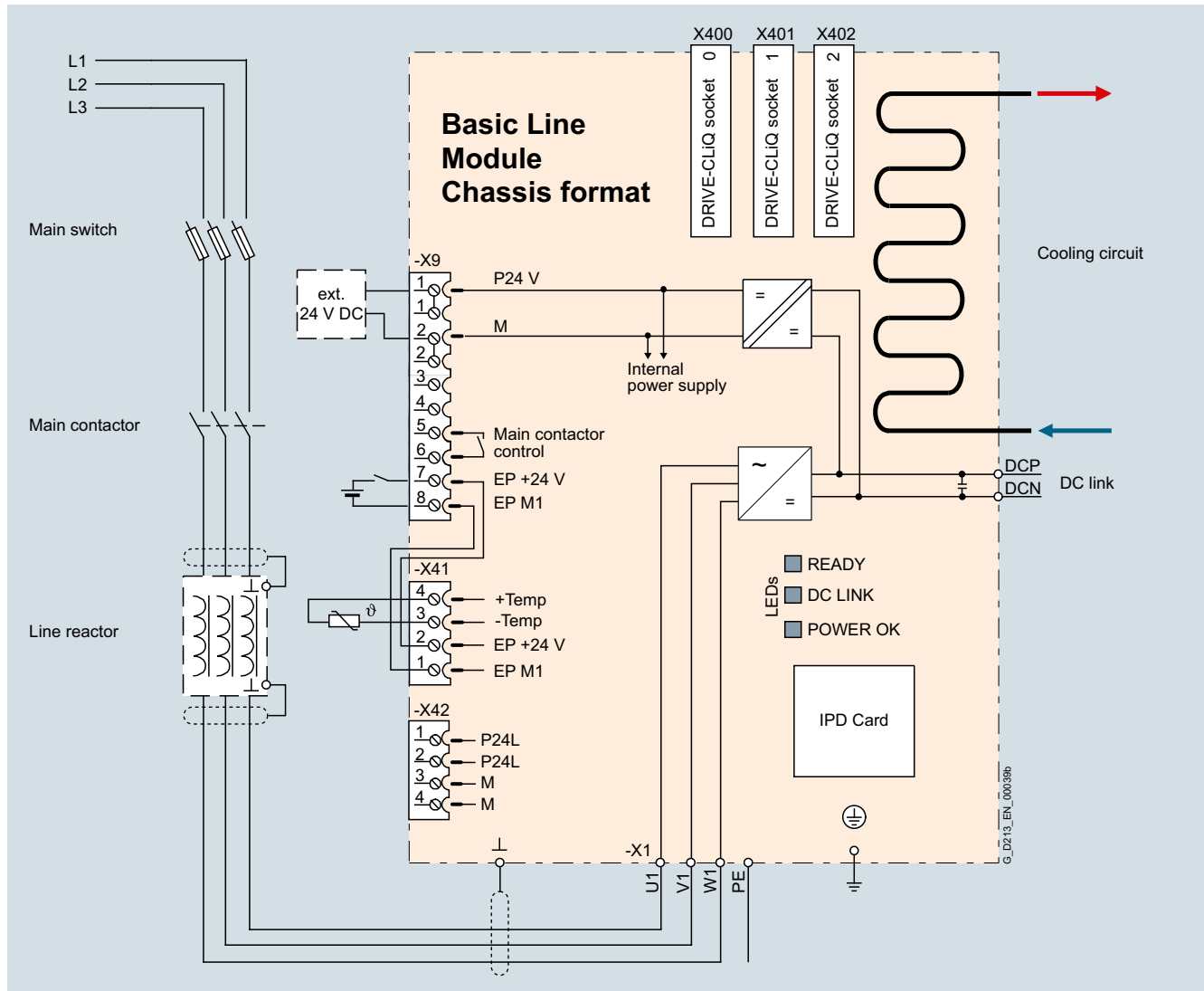

Connection example of a Basic Line Module

Technical specifications

General technical specifications

Electrical specifications

Line power factor at rated power

- Basic fundamental ($\cos \varphi_1$) >0.96
- Total (λ) 0.75 ... 0.93

Efficiency

>99 %

DC link voltage, approx. ¹⁾

$1.35 \times$ line voltage

Main contactor control

- Terminal block -X9/5-6
240 V AC, max. 8 A
30 V DC, max. 1 A

¹⁾ The DC link voltage is unregulated and load-dependent.
For additional information, please refer to the
SINAMICS Low Voltage Engineering Manual.

SINAMICS S120 Chassis Format Converter Units

Liquid-cooled units

Basic Line Modules

Technical specifications (continued)

Line voltage 380 ... 480 V 3 AC		Basic Line Modules		
		6SL3335-1TE37-4AA3	6SL3335-1TE41-2AA3	6SL3335-1TE41-7AA3
Rated power				
• At $I_{\text{rated DC}}$ (50 Hz 400 V)	kW	360	600	830
• At I_{H} (50 Hz 400 V)	kW	280	450	650
• At $I_{\text{rated DC}}$ (60 Hz 460 V)	hp	555	925	1280
• At I_{H} (60 Hz 460 V)	hp	430	690	1000
DC link current				
• Rated current $I_{\text{rated DC}}$	A	740	1220	1730
• Base-load current $I_{\text{H DC}}^{1)}$	A	578	936	1350
• Maximum current $I_{\text{max DC}}$	A	1110	1830	2595
Input current				
• Rated current $I_{\text{rated I}}$	A	610	1000	1420
• Maximum current $I_{\text{max I}}$	A	915	1500	2130
Current demand				
• 24 V DC auxiliary power supply	A	0.7	0.7	0.7
DC link capacitance				
• Basic Line Module	μF	12000	20300	26100
• Drive line-up, max.	μF	96000	162400	208800
Power loss, at 50 Hz 400 V ²⁾				
• Dissipated to coolant	kW	2.7	4.36	5.82
• Dissipated to ambient air	kW	0.25	0.41	0.57
• Total	kW	2.95	4.77	6.39
Coolant volume flow ³⁾				
	l/min	9	9	12
Liquid volume of the integrated heat exchanger				
	dm ³	0.45	0.45	0.79
Pressure drop, typ. ⁴⁾ for volume flow				
	Pa	70000	70000	70000
Heat exchanger material				
		Aluminum	Aluminum	Aluminum
Sound pressure level L_{pA} (1 m) at 50/60 Hz				
	dB	54	56	56
Line connection U1, V1, W1				
		2 × M12 nut	2 × M12 nut	2 × M12 nut
• Conductor cross section, max. (IEC)	mm ²	4 × 240	4 × 240	4 × 240
DC link connection DCP, DCN				
		2 × M12 nut Busbar	2 × M12 nut Busbar	2 × M12 nut Busbar
PE/GND connection				
• Conductor cross section, max. (IEC)	mm ²	4 × 240	4 × 240	4 × 240
Cable length, max. ⁵⁾				
• Shielded	m	2600	4000	4800
• Unshielded	m	3900	6000	7200
Dimensions				
• Width	mm	160	160	160
• Height	mm	1137	1137	1562
• Depth	mm	545	545	545
Weight, approx.				
	kg	108	108	185
Frame size				
		FBL	FBL	GBL
Minimum short-circuit current ⁶⁾				
	A	8800	12400	20000

¹⁾ The base-load current $I_{\text{H DC}}$ is the basis for a duty cycle of 150 % for 60 s or $I_{\text{max DC}}$ for 5 s with a duty cycle duration of 300 s.

²⁾ The specified power loss represents the maximum value at 100% utilization. The value is lower under normal operating conditions. To ensure safe dissipation of the minor power loss released to the ambient air, it is important to follow the instructions pertaining to control cabinet installation in the SINAMICS Low Voltage Engineering Manual.

³⁾ The value applies to coolants comprising water and a mixture of water and anti-freeze agent.

⁴⁾ The value is valid for water as coolant. [Additional information and notes on other coolants is provided in the SINAMICS Low Voltage Engineering Manual.](#)

⁵⁾ Total of all motor cables and DC link. Longer cable lengths for specific configurations are available on request. [For additional information, please refer to the SINAMICS Low Voltage Engineering Manual.](#)

⁶⁾ Current required for reliably triggering protective devices.

SINAMICS S120 Chassis Format Converter Units

Liquid-cooled units

Basic Line Modules

Technical specifications (continued)

Line voltage 500 ... 690 V 3 AC		Basic Line Modules			
		6SL3335-1TG34-2AA3	6SL3335-1TG37-3AA3	6SL3335-1TG41-3AA3	6SL3335-1TG41-7AA3
Rated power					
• At $I_{\text{rated DC}}$ (50 Hz 690 V)	kW	355	630	1100	1370
• At I_{H} (50 Hz 690 V)	kW	275	475	840	1070
• At $I_{\text{rated DC}}$ (50 Hz 500 V)	kW	245	420	750	950
• At I_{H} (50 Hz 500 V)	kW	200	345	610	775
• At $I_{\text{rated DC}}$ (60 Hz 575 V)	hp	395	705	1230	1530
• At I_{H} (60 Hz 575 V)	hp	305	530	940	1195
DC link current					
• Rated current $I_{\text{rated DC}}$	A	420	730	1300	1650
• Base-load current $I_{\text{H DC}}^{1)}$	A	328	570	1014	1287
• Maximum current $I_{\text{max DC}}$	A	630	1095	1950	2475
Input current					
• Rated current $I_{\text{rated I}}$	A	340	600	1070	1350
• Maximum current $I_{\text{max I}}$	A	510	900	1605	2025
Current demand					
• 24 V DC auxiliary power supply	A	0.7	0.7	0.7	0.7
DC link capacitance					
• Basic Line Module	μF	4800	7700	15500	19300
• Drive line-up, max.	μF	38400	61600	124000	154400
Power loss, at 50 Hz 690 V²⁾					
• Dissipated to coolant	kW	1.55	2.71	4.66	5.7
• Dissipated to ambient air	kW	0.21	0.38	0.43	0.55
• Total	kW	1.76	3.09	5.09	6.25
Coolant volume flow³⁾	l/min	9	9	12	12
Liquid volume of the integrated heat exchanger	dm ³	0.45	0.45	0.79	0.79
Pressure drop, typ.⁴⁾ for volume flow	Pa	70000	70000	70000	70000
Heat exchanger material		Aluminum	Aluminum	Aluminum	Aluminum
Sound pressure level L_{pA} (1 m) at 50/60 Hz	dB	54	54	56	56
Line connection U1, V1, W1		2 × M12 nut	2 × M12 nut	2 × M12 nut	2 × M12 nut
• Conductor cross section, max. (IEC)	mm ²	4 × 240	4 × 240	4 × 240	4 × 240
DC link connection DCP, DCN		2 × M12 nut Busbar	2 × M12 nut Busbar	2 × M12 nut Busbar	2 × M12 nut Busbar
PE/GND connection		2 × M12 nut	2 × M12 nut	2 × M12 nut	2 × M12 nut
• Conductor cross section, max. (IEC)		4 × 240	4 × 240	4 × 240	4 × 240
Cable length, max.⁵⁾					
• Shielded	m	1500	1500	2250	2250
• Unshielded	m	2250	2250	3375	3375
Dimensions					
• Width	mm	160	160	160	160
• Height	mm	1137	1137	1562	1562
• Depth	mm	545	545	545	545
Weight, approx.	kg	108	108	185	185
Frame size		FBL	FBL	GBL	GBL
Minimum short-circuit current⁶⁾	A	4400	7200	16800	18900

1) The base-load current $I_{\text{H DC}}$ is the basis for a duty cycle of 150 % for 60 s or $I_{\text{max DC}}$ for 5 s with a duty cycle duration of 300 s.

2) The specified power loss represents the maximum value at 100% utilization. The value is lower under normal operating conditions. To ensure safe dissipation of the minor power loss released to the ambient air, it is important to follow the instructions pertaining to control cabinet installation in the SINAMICS Low Voltage Engineering Manual.

3) The value applies to coolants comprising water and a mixture of water and anti-freeze agent.

4) The value is valid for water as coolant. [Additional information and notes on other coolants is provided in the SINAMICS Low Voltage Engineering Manual.](#)

5) Total of all motor cables and DC link. Longer cable lengths for specific configurations are available on request. [For additional information, please refer to the SINAMICS Low Voltage Engineering Manual.](#)

6) Current required for reliably triggering protective devices.

SINAMICS S120 Chassis Format Converter Units

Liquid-cooled units

Active Line Modules

Overview



The self-commutated infeed/regenerative feedback units (with IGBTs in infeed and regenerative feedback directions) generate a regulated DC link voltage. This means that the connected Motor Modules are decoupled from the line voltage. Line voltage fluctuations within the permissible supply tolerances have no effect on the motor voltage.

If required, the Active Line Modules can also provide reactive power compensation.

Active Line Modules are designed for connection to grounded TN/TT and non-grounded IT supply systems.

Liquid-cooled Active Line Modules are especially suitable for applications where installation space is restricted and environmental conditions are harsh. Liquid cooling ensures efficient heat dissipation.

Active Line Modules are always operated together with the associated Active Interface Modules. These include the necessary pre-charging circuit as well as a Clean Power Filter.

Design

The liquid-cooled Active Line Modules have the following interfaces as standard:

- 1 line supply connection
- 1 connection for the 24 V DC electronics power supply
- 1 DC link connection (DCP, DCN) for supplying the connected Motor Modules
- 3 DRIVE-CLiQ sockets
- 1 temperature sensor input (KTY84-130, PTC or Pt100)
- 1 PE connection
- 2 coolant connections

The status of the Active Line Modules is indicated via three LEDs.

The following are included in the scope of supply of the Active Line Modules:

- 1 DRIVE-CLiQ cable for connection to the Control Unit
- 2 seals for coolant connections
- 1 set of warning labels in 30 languages (BG, CN, CZ, DE, DK, EE, ES, FI, FR, GB, GR, HU, IE, IS, IT, JP, KR, LT, LV, MT, NL, NO, PL, PT, RO, RU, SE, SI, SK, TR)

¹⁾ Recommended components for installing a flow control as condensation protection; manufactured by Siemens Building Technologies.

Selection and ordering data

Rated power at 400 V or 690 V kW	Rated infeed/ regenerative feedback current A	Active Line Module Article No.
Line voltage 380 ... 480 V 3 AC		
300	490	6SL3335-7TE35-0AA3
380	605	6SL3335-7TE36-1AA3
500	840	6SL3335-7TE38-4AA3
630	985	6SL3335-7TE41-0AA3
900	1405	6SL3335-7TE41-4AA3
Line voltage 500 ... 690 V 3 AC		
630	575	6SL3335-7TG35-8AA3
800	735	6SL3335-7TG37-4AA3
900	810	6SL3335-7TG38-1AA3
1100	1020	6SL3335-7TG41-0AA3
1400	1270	6SL3335-7TG41-3AA3
1700	1560	6SL3335-7TG41-6AA3
Description		Article No.
Accessories		
3-way valve ¹⁾		VXF41.../VXG41...
Actuator for 3-way valve ¹⁾		SAX31...
• 230 V 1 AC • 24 V AC/DC		SAX61.../SAX81...
Accessories for re-ordering		
Dust protection blanking plugs (50 units) For DRIVE-CLiQ port		6SL3066-4CA00-0AA0

For line-side components and recommended system components, see Components.

SINAMICS S120 Chassis Format Converter Units

Liquid-cooled units

Active Line Modules

Integration

Active Line Modules are always operated together with the associated Active Interface Modules. Active Interface Modules contain a Clean Power Filter with basic RI suppression, the pre-charging circuit for the Active Line Module, line supply voltage sensing circuit and monitoring sensors.

The liquid-cooled Active Line Modules communicate with the higher-level control module via DRIVE-CLiQ. The control module in this case can be a CU320-2 or a SIMOTION D Control Unit. An external 24 V DC power supply is required to operate the Active Line Modules.

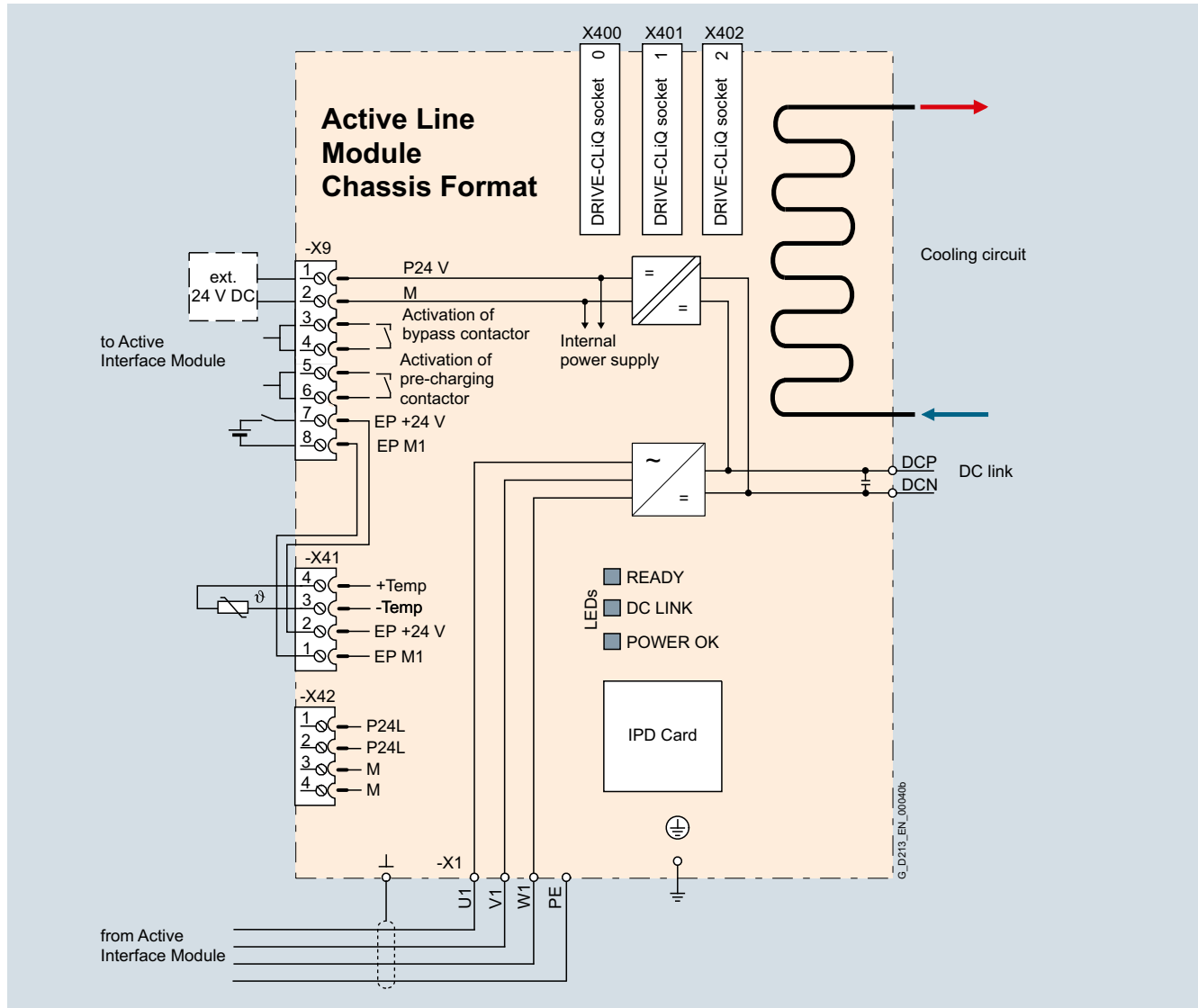

Connection example of an Active Line Module

Technical specifications

General technical specifications

Electrical specifications

Line power factor

- Basic fundamental ($\cos \varphi_1$) 1 (factory setting), can be altered by inputting a reactive current setpoint
- Total (λ) 1 (factory setting)

Efficiency

- >98.5 % (Active Line Modules)
- >99 % (Active Interface Module)

DC link voltage, approx.

The DC link voltage is regulated and can be adjusted as a voltage decoupled from the line voltage. Factory setting of the DC link voltage: $1.5 \times$ line voltage

SINAMICS S120 Chassis Format Converter Units

Liquid-cooled units

Active Line Modules

Technical specifications (continued)

Line voltage 380 V ... 480 V 3 AC		Active Line Modules				
		6SL3335-7TE35-0AA3	6SL3335-7TE36-1AA3	6SL3335-7TE38-4AA3	6SL3335-7TE41-0AA3	6SL3335-7TE41-4AA3
Rated power						
• At $I_{\text{rated DC}}$ (50 Hz 400 V)	kW	300	380	500	630	900
• At $I_{\text{H DC}}$ (50 Hz 400 V)	kW	270	335	465	545	780
• At $I_{\text{rated DC}}$ (60 Hz 460 V)	hp	500	600	700	900	1250
• At $I_{\text{H DC}}$ (60 Hz 460 V)	hp	400	500	700	800	1000
DC link current						
• Rated current $I_{\text{rated DC}}$	A	549	677	941	1100	1573
• Base-load current $I_{\text{H DC}}^{1)}$	A	489	603	837	982	1401
• Maximum current $I_{\text{max DC}}$	A	823	1017	1410	1654	2361
Infeed/regenerative feedback current						
• Rated current $I_{\text{rated I}}$	A	490	605	840	985	1405
• Maximum current $I_{\text{max I}}$	A	735	907	1260	1477	2055
Current demand						
• 24 V DC auxiliary power supply	A	1.5	1.6	1.6	1.6	1.6
DC link capacitance						
• Active Line Module	μF	9600	12600	17400	18900	28800
Pulse frequency						
	kHz	4	2.5	2.5	2.5	2.5
Power loss, at 50 Hz 400 V²⁾						
• Dissipated to coolant	kW	3.42	4.65	5.52	7.46	9.58
• Dissipated to ambient air	kW	0.14	0.17	0.23	0.44	0.62
• Total	kW	3.56	4.82	5.75	7.9	10.2
Coolant volume flow³⁾						
	l/min	12	16	16	27	27
Liquid volume of the integrated heat exchanger						
	dm^3	0.91	0.74	0.74	1.56	1.56
Pressure drop, typ.⁴⁾ for volume flow						
	Pa	70000	70000	70000	70000	70000
Heat exchanger material						
		Stainless steel	Aluminum	Aluminum	Aluminum	Aluminum
Sound pressure level $L_{\text{pA}}^{5)}$ (1 m) at 50/60 Hz						
	dB	69/73	70/73	70/73	71/73	71/73
Line connection U1, V1, W1						
		Hole for M12	2 x hole for M12	2 x hole for M12	2 x hole for M12	2 x hole for M12
• Conductor cross section, max. (IEC)	mm^2	2 x 240	4 x 185	4 x 185	Busbar	Busbar
DC link connection DCP, DCN						
		2 x hole for M12 Busbar	2 x hole for M12 Busbar	2 x hole for M12 Busbar	2 x hole for M12 Busbar	2 x hole for M12 Busbar
PE/GND connection						
		2 x hole for M12	2 x hole for M12	2 x hole for M12	2 x hole for M12	2 x hole for M12
• Conductor cross section, max. (IEC)	mm^2	2 x 240	4 x 185	4 x 185	4 x 240	4 x 240
Cable length, max.⁶⁾						
• Shielded	m	2700	3900	3900	3900	3900
• Unshielded	m	4050	5850	5850	5850	5850
Dimensions						
• Width	mm	150	265	265	295	295
• Height	mm	1172	1002	1002	1516	1516
• Depth	mm	545	545	545	545	545
Weight, approx.						
	kg	80	110	110	220	220
Frame size						
		GXL	HXL	HXL	JXL	JXL
Minimum short-circuit current⁷⁾						
	A	8000	9200	10400	16000	21000

¹⁾ The base-load current $I_{\text{H DC}}$ is the basis for a duty cycle of 150 % for 60 s or $I_{\text{max DC}}$ for 5 s with a duty cycle duration of 300 s.

²⁾ The specified power loss represents the maximum value at 100% utilization. The value is lower under normal operating conditions. To ensure safe dissipation of the minor power loss released to the ambient air, it is important to follow the instructions pertaining to control cabinet installation in the SINAMICS Low Voltage Engineering Manual.

³⁾ The value applies to coolants comprising water and a mixture of water and anti-freeze agent.

⁴⁾ The value is valid for water as coolant. [Additional information and notes on other coolants is provided in the SINAMICS Low Voltage Engineering Manual.](#)

⁵⁾ Total sound pressure level of Active Interface Module and Active Line Module.

⁶⁾ Total of all motor cables and DC link. Longer cable lengths for specific configurations are available on request. [For additional information, please refer to the SINAMICS Low Voltage Engineering Manual.](#)

⁷⁾ Current required for reliably triggering protective devices.

SINAMICS S120 Chassis Format Converter Units

Liquid-cooled units

Active Line Modules

Technical specifications (continued)

Line voltage 500 V ... 690 V 3 AC		Active Line Modules					
		6SL3335-7TG35-8AA3	6SL3335-7TG37-4AA3	6SL3335-7TG38-1AA3	6SL3335-7TG41-0AA3	6SL3335-7TG41-3AA3	6SL3335-7TG41-6AA3
Rated power							
• At $I_{\text{rated DC}}$ (50 Hz 690 V)	kW	630	800	900	1100	1400	1700
• At $I_{\text{H DC}}$ (50 Hz 690 V)	kW	620	705	670	1000	1215	1490
• At $I_{\text{rated DC}}$ (50 Hz 500 V)	kW	447	560	620	780	965	1180
• At $I_{\text{H DC}}$ (50 Hz 500 V)	kW	450	510	485	710	880	1080
• At $I_{\text{rated DC}}$ (60 Hz 575 V)	hp	675	900	975	1250	1500	1880
• At $I_{\text{H DC}}$ (60 Hz 575 V)	hp	506	600	765	1000	1250	1530
DC link current							
• Rated current $I_{\text{rated DC}}$	A	644	823	907	1147	1422	1740
• Base-load current $I_{\text{H DC}}^{1)}$	A	573	732	808	1022	1266	1550
• Maximum current $I_{\text{max DC}}$	A	966	1235	1360	1722	2133	2620
Infeed/regenerative feedback current							
• Rated current $I_{\text{rated I}}$	A	575	735	810	1020	1270	1560
• Maximum current $I_{\text{max I}}$	A	862	1100	1214	1537	1905	2055
Current demand							
• 24 V DC auxiliary power supply	A	1.6	1.6	1.6	1.6	1.46	1.5
DC link capacitance							
• Active Line Module	μF	9670	10500	10500	19330	19330	21000
Pulse frequency							
	kHz	2.5	2.5	2.5	2.5	2.5	2.5
Power loss, at 50 Hz 690 V²⁾							
• Dissipated to coolant	kW	5.45	7.45	8.28	10.37	12.98	17.17
• Dissipated to ambient air	kW	0.16	0.2	0.22	0.53	0.57	0.79
• Total	kW	5.61	7.65	8.5	10.9	13.55	17.96
Coolant volume flow³⁾							
	l/min	16	16	16	27	27	27
Liquid volume of the integrated heat exchanger							
	dm ³	0.74	0.74	0.74	1.56	1.56	1.56
Pressure drop, typ.⁴⁾ for volume flow							
	Pa	70000	70000	70000	70000	70000	70000
Heat exchanger material							
		Aluminum	Aluminum	Aluminum	Aluminum	Aluminum	Aluminum
Sound pressure level L_{pA}⁵⁾ (1 m) at 50/60 Hz							
	dB	70/73	71/73	71/73	71/73	71/73	71/73
Line connection U1, V1, W1							
		2 × hole for M12	2 × hole for M12	2 × hole for M12	2 × hole for M12	2 × hole for M12	2 × hole for M12
• Conductor cross section, max. (IEC)	mm ²	4 × 185	4 × 185	4 × 185	Busbar	Busbar	Busbar
DC link connection DCP, DCN							
		2 × hole for M12 Busbar	2 × hole for M12 Busbar	2 × hole for M12 Busbar	2 × hole for M12 Busbar	2 × hole for M12 Busbar	2 × hole for M12 Busbar
PE/GND connection							
		2 × hole for M12	2 × hole for M12	2 × hole for M12	2 × hole for M12	2 × hole for M12	2 × hole for M12
• Conductor cross section, max. (IEC)	mm ²	4 × 185	4 × 185	4 × 185	Busbar	Busbar	Busbar
Cable length, max.⁶⁾							
• Shielded	m	2250	2250	2250	2250	2250	2250
• Unshielded	m	3375	3375	3375	3375	3375	3375
Dimensions							
• Width	mm	265	265	265	295	295	295
• Height	mm	1002	1002	1002	1516	1516	1516
• Depth	mm	545	545	545	545	545	545
Weight, approx.							
	kg	110	110	110	220	220	230
Frame size							
		HXL	HXL	HXL	JXL	JXL	JXL
Minimum short-circuit current⁷⁾							
	A	8400	10500	12600	16000	20000	24000

¹⁾ The base-load current $I_{\text{H DC}}$ is the basis for a duty cycle of 150 % for 60 s or $I_{\text{max DC}}$ for 5 s with a duty cycle duration of 300 s.

²⁾ The specified power loss represents the maximum value at 100% utilization. The value is lower under normal operating conditions. To ensure safe dissipation of the minor power loss released to the ambient air, it is important to follow the instructions pertaining to control cabinet installation in the SINAMICS Low Voltage Engineering Manual.

³⁾ The value applies to coolants comprising water and a mixture of water and anti-freeze agent.

⁴⁾ The value is valid for water as coolant. [Additional information and notes on other coolants is provided in the SINAMICS Low Voltage Engineering Manual.](#)

⁵⁾ Total sound pressure level of Active Interface Module and Active Line Module.

⁶⁾ Total of all motor cables and DC link. Longer cable lengths for specific configurations are available on request. [For additional information, please refer to the SINAMICS Low Voltage Engineering Manual.](#)

⁷⁾ Current required for reliably triggering protective devices.

SINAMICS S120 Chassis Format Converter Units

Liquid-cooled units

Active Interface Modules

Overview

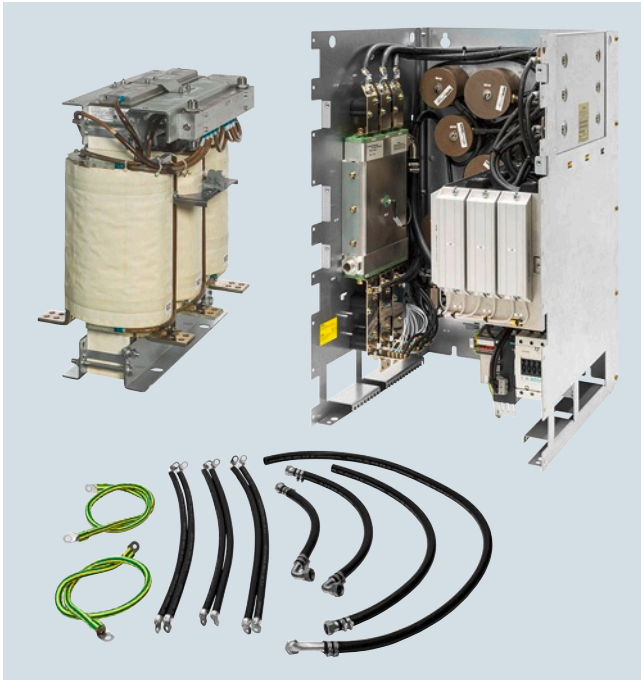

The Active Interface Module essentially comprises a liquid-cooled filter reactor and a liquid-cooled filter module. The filter module contains a Clean Power Filter with basic RI suppression, the pre-charging circuit for the Active Line Module, the line voltage sensing circuit and monitoring sensors.

A bypass contactor is provided separately. Active Interface Modules are used in conjunction with Active Line Modules.

Liquid-cooled Active Interface Modules cannot be supplied for all liquid-cooled Active Line Modules. Where they are not available, air-cooled Active Interface Modules can be ordered instead.

Design

Active Interface Modules have the following interfaces as standard:

- 1 line supply connection
- 1 load connection
- 1 connection for the 24 V DC electronics power supply
- 1 connection for the external 230 V AC supply
- 1 DRIVE-CLiQ socket (on VSM10 Voltage Sensing Module)
- 1 connection for pre-charging circuit
- 1 PE connection
- 2 coolant connections

The scope of supply of the Active Interface Modules includes:

- Liquid-cooled filter reactor
- Liquid-cooled filter module
- Connection kit (cables and hoses)
- DRIVE-CLiQ cable for the connection between Active Interface Module and Active Line Module
- 2 seals for coolant connections
- 1 set of warning labels in 30 languages (BG, CN, CZ, DE, DK, EE, ES, FI, FR, GB, GR, HU, IE, IS, IT, JP, KR, LT, LV, MT, NL, NO, PL, PT, RO, RU, SE, SI, SK, TR)

Selection and ordering data

Suitable for Active Line Module chassis format, liquid-cooled	Rated power of the Active Line Modules at 400 V or 690 V kW	Active Interface Module, liquid-cooled Article No.	Active Interface Module, air-cooled Article No.
Line voltage 380 ... 480 V 3 AC			
6SL3335-7TE35-0AA3	300	– ¹⁾	6SL3300-7TE35-0AA0
6SL3335-7TE36-1AA3	380	– ¹⁾	6SL3300-7TE38-4AA0
6SL3335-7TE38-4AA3	500	– ¹⁾	6SL3300-7TE38-4AA0
6SL3335-7TE41-0AA3	630	6SL3305-7TE41-4AA3	–
6SL3335-7TE41-4AA3	900	6SL3305-7TE41-4AA3	–
Line voltage 500 ... 690 V 3 AC			
6SL3335-7TG35-8AA3	630	– ¹⁾	6SL3300-7TG35-8AA0
6SL3335-7TG37-4AA3	800	6SL3305-7TG37-4AA3	–
6SL3335-7TG38-1AA3	900	6SL3305-7TG41-0AA3	–
6SL3335-7TG41-0AA3	1100	6SL3305-7TG41-0AA3	–
6SL3335-7TG41-3AA3	1400	6SL3305-7TG41-3AA3	–
6SL3335-7TG41-6AA3	1700	6SL3305-7TG41-6AA3	–

¹⁾ For these power ratings, no liquid-cooled Active Interface Modules are available. As an alternative, air-cooled units can be used. See column on the right and further information about the air-cooled Active Interface Modules, page 3/30 onward.

SINAMICS S120 Chassis Format Converter Units

Liquid-cooled units

Active Interface Modules

Integration

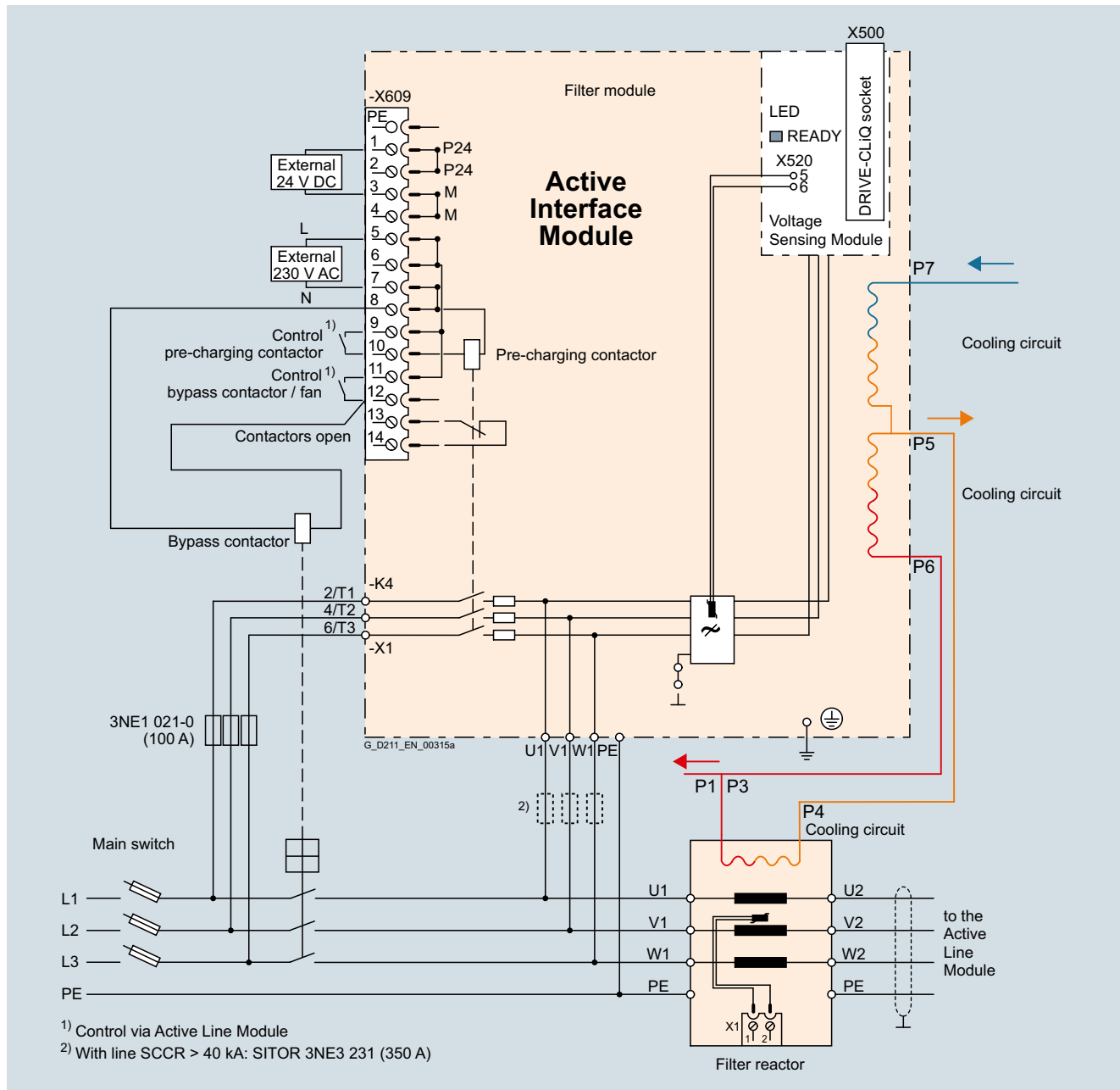

Connection example of liquid-cooled Active Interface Module with external bypass contactor

3

SINAMICS S120 Chassis Format Converter Units

Liquid-cooled units

Active Interface Modules

Technical specifications

Line voltage 380 ... 480 V 3 AC		Active Interface Module	
		6SL3305-7TE41-4AA3	
Suitable for Active Line Module			
• Rated power at 400 V - Liquid-cooled	kW	900/630 6SL3335-7TE41-4AA3 6SL3335-7TE41-0AA3	
Rated current	A	1405	
Bypass contactor ¹⁾		3WL1116-2BB34-4AN2-Z Z = C22 ²⁾	
Current demand			
• 24 V DC auxiliary power supply	A	0.17	
• 230 V 2 AC			
- Inrush current	A	1.0	
- Holding current	A	0.1	
DC link capacitance of the drive line-up, max. ³⁾	µF	230400	
Coolant volume flow	l/min	16	
Pressure drop, typ. for volume flow	Pa	70000	
Sound pressure level L_{pA} (1 m) at 50/60 Hz	dB	71/71	
Frame size		JIL	
Filter reactor			
Power loss ⁴⁾			
• At 50 Hz 400 V	kW	8.6	
• At 60 Hz 460 V	kW	8.6	
• Dissipated to ambient air	kW	0.9	
Liquid volume			
• Of integrated reactor cooler	dm ³	0.6	
• Of hoses supplied	dm ³ /m	0.285	
Coolant volume flow	l/min	8	
Pressure drop, typ. for volume flow	Pa	70000	
Heat exchanger material		Aluminum	
Line/load connection L1, L2, L3 / U2, V2, W2		Flat connector for M12 screws	
PE/GND connection		M10 stud	
• Conductor cross section, max. (IEC)	mm ²	1 × 240	
Degree of protection		IP00	
Dimensions			
• Width	mm	373	
• Height	mm	716	
• Depth	mm	575	
Weight, approx.	kg	299	
Filter module			
Power loss ⁴⁾			
• At 50 Hz 400 V	kW	3.6	
• At 60 Hz 460 V	kW	3.6	
• Dissipated to ambient air	kW	0.15	
Liquid volume	dm ³	1	
Heat exchanger material		Aluminum	
PE/GND connection		Flat connector for M8 screw	
• Conductor cross section, max. (IEC)	mm ²	2 × 120	
Degree of protection		IP00	
Dimensions			
• Width	mm	511	
• Height	mm	840	
• Depth	mm	574	
Weight, approx.	kg	110	

¹⁾ The bypass contactor is not included in the scope of supply.

²⁾ The breakers must always be switched ON and OFF by the sequence control. An interlocking set 3WL9111-0BA21-0AA0 as described in Catalog LV 10 should be provided for the bypass contactor to exclude the risk of unintentional manual operation. Manual operation bypasses the pre-charging circuit and can therefore destroy the Active Line Module.

³⁾ Information on higher capacities is included in the [SINAMICS Low Voltage Engineering Manual](#).

⁴⁾ The specified power loss represents the maximum value at 100% utilization. The value is lower under normal operating conditions. To ensure safe dissipation of the minor power loss released to the ambient air, it is important to follow the instructions pertaining to control cabinet installation in the [SINAMICS Low Voltage Engineering Manual](#).

SINAMICS S120 Chassis Format Converter Units

Liquid-cooled units

Active Interface Modules

Technical specifications (continued)

Line voltage 500 ... 690 V 3 AC		Active Interface Modules			
		6SL3305-7TG37-4AA3	6SL3305-7TG41-0AA3	6SL3305-7TG41-3AA3	6SL3305-7TG41-6AA3
Suitable for Active Line Module					
• Rated power at 690 V - Liquid-cooled	kW	800 6SL3335-7TG37-4AA3	900/1100 6SL3335-7TG38-1AA3 6SL3335-7TG41-0AA3	1400 6SL3335-7TG41-3AA3	1700 6SL3335-7TG41-6AA3
Rated current	A	735	1025	1270	1560
Bypass contactor ¹⁾		3RT1476-6AP36 (3 units)	3WL1212-4BB34-4AN2-Z C22 ²⁾	3WL1216-4BB34-4AN2-Z C22 ²⁾	3WL1216-4BB34-4AN2-Z C22 ²⁾
Current demand					
• 24 V DC auxiliary power supply	A	0.17	0.17	0.17	0.17
• 230 V 2 AC					
- Inrush current	A	1.0	1.0	1.0	1.0
- Holding current	A	0.1	0.1	0.1	0.1
DC link capacitance of the drive line-up, max. ³⁾	µF	153600	153600	153600	210000
Coolant volume flow	l/min	10	16	16	16
Pressure drop, typ. for volume flow	Pa	70000	70000	70000	70000
Sound pressure level L_{pA} (1 m) at 50/60 Hz	dB	71/71	71/71	71/71	71/71
Frame size		JIL	JIL	JIL	JIL
Filter reactor					
Power loss ⁴⁾					
• At 50 Hz 690 V	kW	5.5	6.2	9.3	11.0
• At 60 Hz 575 V	kW	5.5	6.2	9.3	11.0
• Dissipated to ambient air	kW	0.5	0.6	0.95	1.15
Liquid volume					
• Of integrated reactor cooler	dm ³	0.6	0.6	0.6	0.6
• Of hoses supplied	dm ³ /m	0.285	0.285	0.285	0.285
Coolant volume flow	l/min	10	10	10	8
Pressure drop, typ. for volume flow	Pa	70000	70000	70000	70000
Heat exchanger material		Aluminum	Aluminum	Aluminum	Aluminum
Line/load connection L1, L2, L3 / U2, V2, W2		Flat connector for M12 screws	Flat connector for M12 screws	Flat connector for M12 screws	Flat connector for M12 screws
PE/GND connection • Conductor cross section, max. (IEC)	mm ²	M10 stud 1 × 240	M10 stud 1 × 240	M10 stud 1 × 240	M10 stud 1 × 240
Degree of protection		IP00	IP00	IP00	IP00
Dimensions					
• Width	mm	358	440	440	440
• Height	mm	680	705	705	705
• Depth	mm	575	575	575	580
Weight, approx.	kg	324	365	365	460
Filter module					
Power loss ⁴⁾					
• At 50 Hz 690 V	kW	4.0	5.0	5.0	7.5
• At 60 Hz 575 V	kW	4.0	5.0	5.0	7.5
• Dissipated to ambient air	kW	0.15	0.15	0.15	0.15
Liquid volume	dm ³	1	1	1	1
Heat exchanger material		Aluminum	Aluminum	Aluminum	Aluminum
PE/GND connection • Conductor cross section, max. (IEC)	mm ²	Flat connector for M8 screw 2 × 120	Flat connector for M8 screw 2 × 120	Flat connector for M8 screw 2 × 120	Flat connector for M8 screw 2 × 120
Degree of protection		IP00	IP00	IP00	IP00
Dimensions					
• Width	mm	511	511	511	511
• Height	mm	840	840	840	840
• Depth	mm	574	574	574	574
Weight, approx.	kg	110	110	110	110

¹⁾ The bypass contactor is not included in the scope of supply.

²⁾ The breakers must always be switched ON and OFF by the sequence control. An interlocking set 3WL9111-0BA21-0AA0 as described in Catalog LV 10 should be provided for the bypass contactor to exclude the risk of unintentional manual operation. Manual operation bypasses the pre-charging circuit and can therefore destroy the Active Line Module.

³⁾ Information on higher capacities is included in the SINAMICS Low Voltage Engineering Manual.

⁴⁾ The specified power loss represents the maximum value at 100% utilization. The value is lower under normal operating conditions. To ensure safe dissipation of the minor power loss released to the ambient air, it is important to follow the instructions pertaining to control cabinet installation in the SINAMICS Low Voltage Engineering Manual.

SINAMICS S120 Chassis Format Converter Units

Liquid-cooled units

Motor Modules

Overview



A Motor Module comprises a self-commutated inverter with IGBTs. It generates a variable voltage with variable frequency from the DC link voltage that feeds the connected motor.

Multiple Motor Modules can be operated on a single DC link. This permits energy to be transferred between the Motor Modules. This means that if one Motor Module operating in generator mode produces energy, the energy can be used by another Motor Module operating in motor mode.

Motor Modules are controlled by a Control Unit.

Liquid-cooled Motor Modules are especially suitable for applications where installation space is restricted and environmental conditions are harsh. Liquid cooling ensures efficient heat dissipation.

Design

The liquid-cooled Motor Modules have the following interfaces as standard:

- 1 motor connection
- 1 connection for the 24 V DC electronics power supply
- 1 DC link connection (DCP, DCN) for connecting to the supply DC link
- 3 DRIVE-CLiQ sockets
- 1 temperature sensor input (KTY84-130, PTC or Pt100)
- 1 connection for Safe Brake Adapter
- 1 connection for Safety Integrated
- 2 PE connections
- 2 coolant connections

The status of the Motor Modules is indicated via three LEDs.

The scope of supply of the Motor Modules includes:

- 1 DRIVE-CLiQ cable for connection to the Control Unit
- 2 seals for coolant connections
- 1 set of warning labels in 30 languages (BG, CN, CZ, DE, DK, EE, ES, FI, FR, GB, GR, HU, IE, IS, IT, JP, KR, LT, LV, MT, NL, NO, PL, PT, RO, RU, SE, SI, SK, TR)

¹⁾ This Motor Module has been specifically designed for loads demanding a high dynamic performance.

²⁾ Recommended components for installing a flow control as condensation protection; manufactured by Siemens Building Technologies.

Selection and ordering data

Type rating at 400 V or 690 V kW	Rated output current A	Motor Module Article No.
Line voltage 380 ... 480 V 3 AC (DC link voltage 510 ... 720 V DC)		
110	210	6SL3325-1TE32-1AA3
132	260	6SL3325-1TE32-6AA3
160	310	6SL3325-1TE33-1AA3
250	490	6SL3325-1TE35-0AA3
315	605	6SL3325-1TE36-1AA3
400	745	6SL3325-1TE37-5AA3
450	840	6SL3325-1TE38-4AA3
560	985	6SL3325-1TE41-0AA3
710	1260	6SL3325-1TE41-2AA3
800	1405	6SL3325-1TE41-4AA3
800 ¹⁾	1330	6SL3325-1TE41-4AS3
Line voltage 500 ... 690 V 3 AC (DC link voltage 675 ... 1035 V DC)		
90	100	6SL3325-1TG31-0AA3
132	150	6SL3325-1TG31-5AA3
200	215	6SL3325-1TG32-2AA3
315	330	6SL3325-1TG33-3AA3
450	465	6SL3325-1TG34-7AA3
560	575	6SL3325-1TG35-8AA3
710	735	6SL3325-1TG37-4AA3
800	810	6SL3325-1TG38-0AA3
800	810	6SL3325-1TG38-1AA3
1000	1025	6SL3325-1TG41-0AA3
1200	1270	6SL3325-1TG41-3AA3
1500	1560	6SL3325-1TG41-6AA3

Description	Article No.
Accessories	
3-way valve ²⁾	VXF41.../VXG41...
Actuator for 3-way valve ²⁾	
• 230 V 1 AC	SAX31...
• 24 V AC/DC	SAX61.../SAX81...
Accessories for re-ordering	
Dust protection blanking plugs (50 units)	6SL3066-4CA00-0AA0
For DRIVE-CLiQ port	

For motor-side components, see System components.

Integration

The liquid-cooled Motor Modules communicate with the higher-level control module via DRIVE-CLiQ. The control module in this case can be a CU320-2 or a SIMOTION D Control Unit.

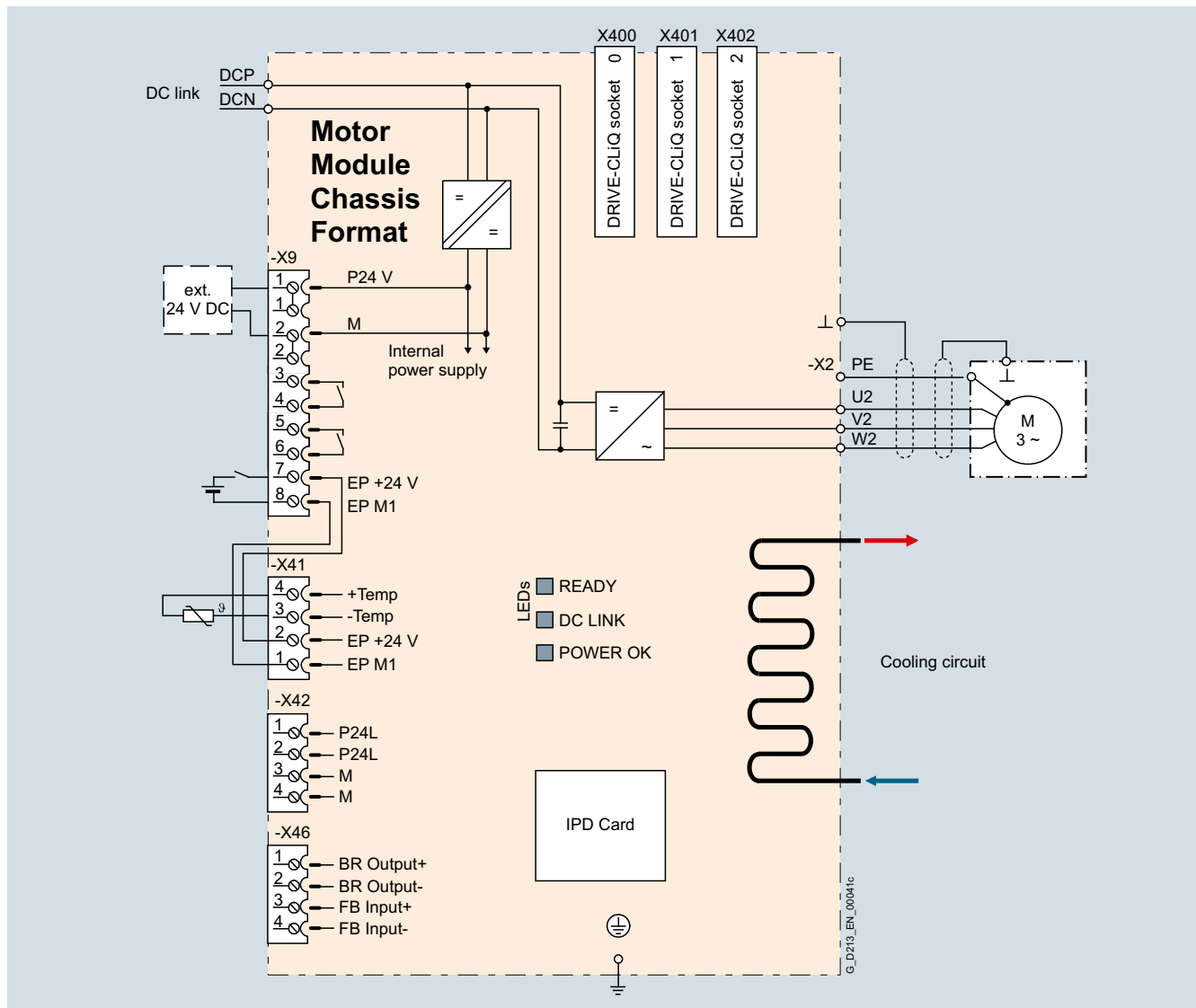

Connection example of a liquid-cooled Motor Module

Technical specifications

General technical specifications

Electrical specifications	
Efficiency	98.5 %
DC link voltage (up to 2000 m above sea level)	510 ... 720 V DC (line supply voltage 380 ... 480 V 3 AC) or 675 ... 1035 V DC (line supply voltage 500 ... 690 V 3 AC)
Output frequency ¹⁾	
• Control type Servo	0 ... 550 Hz
• Control type Vector	0 ... 550 Hz
• Control mode V/f	0 ... 550 Hz
Safety Integrated	Safety Integrity Level 2 (SIL2) acc. to IEC 61508, Performance Level d (PLd) acc. to EN ISO 13849-1 and Control Category 3 acc. to EN ISO 13849-1.

¹⁾ Please note:

- The correlation between maximum output frequency, pulse frequency and current derating. Higher output frequencies on request
- The correlation between the minimum output frequency and permissible output current (current derating). Information is provided in the [SINAMICS Low Voltage Engineering Manual](#).

SINAMICS S120 Chassis Format Converter Units

Liquid-cooled units

Motor Modules

Technical specifications (continued)

Line voltage 380 ... 480 V 3 AC DC link voltage 510 ... 720 V DC		Motor Modules				
		6SL3325-1TE32-1AA3	6SL3325-1TE32-6AA3	6SL3325-1TE33-1AA3	6SL3325-1TE35-0AA3	6SL3325-1TE36-1AA3
Type rating						
• At I_L (50 Hz 400 V) ¹⁾	kW	110	132	160	250	315
• At I_H (50 Hz 400 V) ¹⁾	kW	90	110	132	200	250
• At I_L (60 Hz 460 V) ²⁾	hp	150	200	250	400	500
• At I_H (60 Hz 460 V) ²⁾	hp	150	200	200	350	350
Output current						
• Rated current $I_{rated O}$	A	210	260	310	490	605
• Base-load current $I_L^{(3)}$	A	205	250	302	477	590
• Base-load current $I_H^{(4)}$	A	178	233	277	438	460
• Maximum current $I_{max O}$	A	307	375	453	715	885
DC link current						
• Rated current $I_{rated DC}$ when supplied via						
- Basic Line Module	A	256	317	380	600	738
- Active Line Module	A	230	287	340	538	664
• Base-load current $I_{L DC}^{(3)}$ when supplied via						
- Basic Line Module	A	250	305	368	581	719
- Active Line Module	A	225	274	331	522	646
• Base-load current $I_{H DC}^{(4)}$ when supplied via						
- Basic Line Module	A	227	284	338	534	561
- Active Line Module	A	195	255	303	480	504
Current demand						
• 24 V DC auxiliary power supply	A	1.4	1.4	1.5	1.5	1.6
DC link capacitance		μF	4800	5800	8400	9600
Pulse frequency ⁵⁾						
• Rated frequency	kHz	2	2	2	2	1.25
• Pulse frequency, max.						
- Without current derating	kHz	2	2	2	2	1.25
- With current derating	kHz	8	8	8	8	7.5
Power loss, max. ⁶⁾						
• At 50 Hz 400 V	kW	1.61	1.95	2.29	3.56	4.81
• At 60 Hz 460 V	kW	1.68	2.06	2.38	3.74	5.25
• Dissipated to ambient air	kW	0.06	0.07	0.09	0.14	0.16
Coolant volume flow ⁷⁾		l/min	9	9	12	12
Liquid volume of the integrated heat exchanger		dm ³	0.31	0.31	0.91	0.91
Pressure drop, typ. ⁸⁾ for volume flow		Pa	70000	70000	70000	70000
Heat exchanger material			Stainless steel	Stainless steel	Stainless steel	Stainless steel
Sound pressure level L_{pA} (1 m) at 50/60 Hz		dB	52	52	52	54
DC link connection DCP, DCN			2 × hole for M12 Busbar	2 × hole for M12 Busbar	2 × hole for M12 Busbar	2 × hole for M12 Busbar
Motor connection U2, V2, W2			Hole for M12	Hole for M12	Hole for M12	Hole for M12
• Conductor cross section, max. (IEC)	mm ²	2 × 95	2 × 95	2 × 240	2 × 240	4 × 185
PE/GND connection			2 × hole for M12	2 × hole for M12	2 × hole for M12	2 × hole for M12
• Conductor cross section, max. (IEC)	mm ²	2 × 95	2 × 95	2 × 240	2 × 240	4 × 185

For footnotes, see next page.

SINAMICS S120 Chassis Format Converter Units

Liquid-cooled units

Motor Modules

Technical specifications (continued)

Line voltage 380 ... 480 V 3 AC DC link voltage 510 ... 720 V DC		Motor Modules				
		6SL3325-1TE32-1AA3	6SL3325-1TE32-6AA3	6SL3325-1TE33-1AA3	6SL3325-1TE35-0AA3	6SL3325-1TE36-1AA3
Cable length, max. ⁹⁾						
• Shielded	m	300	300	300	300	300
• Unshielded	m	450	450	450	450	450
Dimensions						
• Width	mm	150	150	150	150	265
• Height	mm	746	746	1172	1172	1002
• Depth	mm	545	545	545	545	545
Weight, approx.	kg	41	41	80	80	110
Frame size		FXL	FXL	GXL	GXL	HXL

¹⁾ Rated output of a typical 6-pole standard induction motor based on I_L or I_H for 400 V 3 AC 50 Hz.

²⁾ Rated output of a typical 6-pole standard induction motor based on I_L or I_H for 460 V 3 AC 60 Hz.

³⁾ The base-load current I_L is based on a load cycle of 110 % for 60 s or 150 % for 10 s with a load cycle duration of 300 s.

⁴⁾ The base-load current I_H is based on a duty cycle of 150 % for 60 s or 160 % for 10 s with a duty cycle duration of 300 s.

⁵⁾ Additional notes regarding the correlation between the pulse frequency and maximum output current/output frequency is provided in the SINAMICS Low Voltage Engineering Manual.

⁶⁾ The specified power loss represents the maximum value at 100% utilization. The value is lower under normal operating conditions. To ensure safe dissipation of the minor power loss released to the ambient air, it is important to follow the instructions pertaining to control cabinet installation in the SINAMICS Low Voltage Engineering Manual.

⁷⁾ The value applies to coolants comprising water and a mixture of water and anti-freeze agent.

⁸⁾ The value is valid for water as coolant. Additional information and notes on other coolants is provided in the SINAMICS Low Voltage Engineering Manual.

⁹⁾ Total of all motor cables. Longer cable lengths for specific configurations are available on request. For additional information, please refer to the SINAMICS Low Voltage Engineering Manual.

SINAMICS S120 Chassis Format Converter Units

Liquid-cooled units

Motor Modules

Technical specifications (continued)

Line voltage 380 ... 480 V 3 AC DC link voltage 510 ... 720 V DC		Motor Modules					
		6SL3325-1TE37-5AA3	6SL3325-1TE38-4AA3	6SL3325-1TE41-0AA3	6SL3325-1TE41-2AA3	6SL3325-1TE41-4AA3	6SL3325-1TE41-4AS3 ¹⁾
Type rating							
• At I_L (50 Hz 400 V) ²⁾	kW	400	450	560	710	800	800
• At I_H (50 Hz 400 V) ²⁾	kW	315	400	450	630	710	630
• At I_L (60 Hz 460 V) ³⁾	hp	600	700	800	1000	1150	1000
• At I_H (60 Hz 460 V) ³⁾	hp	450	600	700	900	1000	900
Output current							
• Rated current $I_{rated\ O}$	A	745	840	985	1260	1405	1330
• Base-load current $I_L^{4)}$	A	725	820	960	1230	1370	1310
• Base-load current $I_H^{5)}$	A	570	700	860	1127	1257	1150
• Maximum current $I_{max\ O}$	A	1087	1230	1440	1845	2055	2055
DC link current							
• Rated current $I_{rated\ DC}$ when supplied via							
- Basic Line Module	A	894	1025	1202	1512	1714	1550
- Active Line Module	A	805	922	1080	1361	1544	1403
• Base-load current $I_{L\ DC}^{4)}$ when supplied from							
- Basic Line Module	A	871	1000	1170	1474	1670	1525
- Active Line Module	A	784	898	1051	1326	1500	1405
• Base-load current $I_{H\ DC}^{5)}$ when supplied from							
- Basic Line Module	A	795	853	1048	1345	1532	1676
- Active Line Module	A	716	767	942	1211	1377	1403
Current demand							
• 24 V DC auxiliary power supply	A	1.6	1.6	1.46	1.46	1.46	1.46
DC link capacitance		μF	17400	17400	21000	29000	21000
Pulse frequency⁶⁾							
• Rated frequency	kHz	1.25	1.25	1.25	1.25	1.25	2
• Pulse frequency, max.							
- Without current derating	kHz	1.25	1.25	1.25	1.25	1.25	2
- With current derating	kHz	7.5	7.5	7.5	7.5	7.5	4
Power loss, max.⁷⁾							
• At 50 Hz 400 V	kW	5.1	5.75	7.9	9.15	10.2	10.9
• At 60 Hz 460 V	kW	5.61	6.33	8.55	10.05	11.2	12.3
• Dissipated to ambient air	kW	0.2	0.23	0.44	0.56	0.62	0.65
Coolant volume flow⁸⁾		l/min	16	16	27	27	27
Liquid volume of the integrated heat exchanger		dm ³	0.74	0.74	1.56	1.56	1.56
Pressure drop, typ.⁹⁾ for volume flow		Pa	70000	70000	70000	70000	70000
Heat exchanger material			Aluminum	Aluminum	Aluminum	Aluminum	Aluminum
Sound pressure level L_{pA} (1 m) at 50/60 Hz		dB	54	54	56	56	56
DC link connection DCP, DCN			2 × hole for M12 busbar	2 × hole for M12 busbar	2 × hole for M12 busbar	2 × hole for M12 busbar	2 × hole for M12 busbar
Motor connection U2, V2, W2			2 × hole for M12	2 × hole for M12	2 × hole for M12	2 × hole for M12	2 × hole for M12
• Conductor cross section, max. (IEC)	mm ²	4 × 185	4 × 185	4 × 240	4 × 240	4 × 240	4 × 240
PE/GND connection			2 × hole for M12	2 × hole for M12	2 × hole for M12	2 × hole for M12	2 × hole for M12
• Conductor cross section, max. (IEC)	mm ²	4 × 185	4 × 185	Busbar	Busbar	Busbar	Busbar

For footnotes, see next page.

SINAMICS S120 Chassis Format Converter Units

Liquid-cooled units

Motor Modules

Technical specifications (continued)

Line voltage 380 ... 480 V 3 AC DC link voltage 510 ... 720 V DC		Motor Modules					
		6SL3325-1TE37-5AA3	6SL3325-1TE38-4AA3	6SL3325-1TE41-0AA3	6SL3325-1TE41-2AA3	6SL3325-1TE41-4AA3	6SL3325-1TE41-4AS3 ¹⁾
Cable length, max. ¹⁰⁾							
• Shielded	m	300	300	300	300	300	300
• Unshielded	m	450	450	450	450	450	450
Dimensions							
• Width	mm	265	265	295	295	295	295
• Height	mm	1002	1002	1516	1516	1516	1516
• Depth	mm	545	545	545	545	545	545
Weight, approx.	kg	110	110	220	220	220	230
Frame size		HXL	HXL	JXL	JXL	JXL	JXL

3

¹⁾ This Motor Module has been specifically designed for loads demanding a high dynamic performance. The derating factor k_{IGBT} and the derating characteristics can be ignored (see section "Duty cycles" in the SINAMICS Low Voltage Engineering Manual).

²⁾ Rated output of a typical 6-pole standard induction motor based on I_L or I_H for 400 V 3 AC 50 Hz.

³⁾ Rated output of a typical 6-pole standard induction motor based on I_L or I_H for 460 V 3 AC 60 Hz.

⁴⁾ The base-load current I_L is based on a load cycle of 110 % for 60 s or 150 % for 10 s with a load cycle duration of 300 s.

⁵⁾ The base-load current I_H is based on a duty cycle of 150 % for 60 s or 160 % for 10 s with a duty cycle duration of 300 s.

⁶⁾ Additional notes regarding the correlation between the pulse frequency and maximum output current/output frequency is provided in the SINAMICS Low Voltage Engineering Manual.

⁷⁾ The specified power loss represents the maximum value at 100% utilization. The value is lower under normal operating conditions. To ensure safe dissipation of the minor power loss released to the ambient air, it is important to follow the instructions pertaining to control cabinet installation in the SINAMICS Low Voltage Engineering Manual.

⁸⁾ The value applies to coolants comprising water and a mixture of water and anti-freeze agent.

⁹⁾ The value is valid for water as coolant. Additional information and notes on other coolants is provided in the SINAMICS Low Voltage Engineering Manual.

¹⁰⁾ Sum of all motor cables. Longer cable lengths for specific configurations are available on request. For additional information, please refer to the SINAMICS Low Voltage Engineering Manual.

SINAMICS S120 Chassis Format Converter Units

Liquid-cooled units

Motor Modules

Technical specifications (continued)

Line voltage 500 ... 690 V 3 AC DC link voltage 675 ... 1035 V DC		Motor Modules					
		6SL3325-1TG31-0AA3	6SL3325-1TG31-5AA3	6SL3325-1TG32-2AA3	6SL3325-1TG33-3AA3	6SL3325-1TG34-7AA3	6SL3325-1TG35-8AA3
Type rating							
• At I_L (50 Hz 690 V) ¹⁾	kW	90	132	200	315	450	560
• At I_H (50 Hz 690 V) ¹⁾	kW	75	110	160	250	400	450
• At I_L (50 Hz 500 V) ¹⁾	kW	55	90	132	200	315	400
• At I_H (50 Hz 500 V) ¹⁾	kW	55	90	132	200	250	315
• At I_L (60 Hz 575 V) ²⁾	hp	75	150	200	300	450	600
• At I_H (60 Hz 575 V) ²⁾	hp	75	125	200	250	450	500
Output current							
• Rated current $I_{rated O}$	A	100	150	215	330	465	575
• Base-load current $I_L^{(3)}$	A	95	142	208	320	452	560
• Base-load current $I_H^{(4)}$	A	89	134	192	280	416	514
• Maximum current $I_{max O}$	A	142	213	312	480	678	840
DC link current							
• Rated current $I_{rated DC}$ when supplied via							
- Basic Line Module	A	122	183	263	403	558	702
- Active Line Module	A	110	165	237	363	502	632
• Base-load current $I_{L DC}^{(3)}$ when supplied via							
- Basic Line Module	A	116	173	253	390	544	683
- Active Line Module	A	105	156	229	352	489	616
• Base-load current $I_{H DC}^{(4)}$ when supplied from							
- Basic Line Module	A	108	163	234	341	496	627
- Active Line Module	A	98	147	211	308	446	565
Current demand							
• 24 V DC auxiliary power supply	A	1.0	1.0	1.5	1.5	1.6	1.6
DC link capacitance	μF	2800	2800	4200	5800	9670	9670
Pulse frequency ⁵⁾							
• Rated frequency	kHz	1.25	1.25	1.25	1.25	1.25	1.25
• Pulse frequency, max.							
- Without current derating	kHz	1.25	1.25	1.25	1.25	1.25	1.25
- With current derating	kHz	7.5	7.5	7.5	7.5	7.5	7.5
Power loss, max. ⁶⁾							
• At 50 Hz 690 V	kW	1.15	1.64	2.34	3.38	5.44	5.61
• At 60 Hz 575 V	kW	1.02	1.45	2.05	2.96	5.1	5.45
• Dissipated to ambient air	kW	0.06	0.07	0.09	0.12	0.14	0.16
Coolant volume flow ⁷⁾	l/min	9	9	12	12	16	16
Liquid volume of the integrated heat exchanger	dm ³	0.31	0.31	0.91	0.91	0.74	0.74
Pressure drop, typ. ⁸⁾ for volume flow	Pa	70000	70000	70000	70000	70000	70000
Heat exchanger material		Stainless steel	Stainless steel	Stainless steel	Stainless steel	Aluminum	Aluminum
Sound pressure level L_{pA} (1 m) at 50/60 Hz	dB	52	52	52	52	54	54
DC link connection DCP, DCN		2 × hole for M12 busbar	2 × hole for M12 busbar	2 × hole for M12 busbar	2 × hole for M12 busbar	2 × hole for M12 busbar	2 × hole for M12 busbar
Motor connection U2, V2, W2		Hole for M12	Hole for M12	Hole for M12	Hole for M12	2 × hole for M12	2 × hole for M12
• Conductor cross section, max. (IEC)	mm ²	2 × 95	2 × 95	4 × 240	4 × 240	4 × 185	4 × 185

For footnotes, see next page.

SINAMICS S120 Chassis Format Converter Units

Liquid-cooled units

Motor Modules

Technical specifications (continued)

Line voltage 500 ... 690 V 3 AC DC link voltage 675 ... 1035 V DC		Motor Modules					
		6SL3325-1TG31-0AA3	6SL3325-1TG31-5AA3	6SL3325-1TG32-2AA3	6SL3325-1TG33-3AA3	6SL3325-1TG34-7AA3	6SL3325-1TG35-8AA3
PE/GND connection		2 × hole for M12					
• Conductor cross section, max. (IEC)	mm ²	2 × 95	2 × 95	2 × 240	2 × 240	4 × 185	4 × 185
Cable length, max. ⁹⁾							
• Shielded	m	300	300	300	300	300	300
• Unshielded	m	450	450	450	450	450	450
Dimensions							
• Width	mm	150	150	150	150	265	265
• Height	mm	728	728	1172	1172	1002	1002
• Depth	mm	545	545	545	545	545	545
Weight, approx.	kg	41	41	80	80	110	110
Frame size		FXL	FXL	GXL	GXL	HXL	HXL

¹⁾ Rated output of a typical 6-pole standard induction motor based on I_L or I_H for 500 V or 690 V 3 AC 50 Hz.

²⁾ Rated output of a typical 6-pole standard induction motor based on I_L or I_H for 575 V 3 AC 60 Hz.

³⁾ The base-load current I_L is based on a load cycle of 110 % for 60 s or 150 % for 10 s with a load cycle duration of 300 s.

⁴⁾ The base-load current I_H is based on a duty cycle of 150 % for 60 s or 160 % for 10 s with a duty cycle duration of 300 s.

⁵⁾ [Additional notes regarding the correlation between the pulse frequency and maximum output current/output frequency is provided in the SINAMICS Low Voltage Engineering Manual.](#)

⁶⁾ The specified power loss represents the maximum value at 100% utilization. The value is lower under normal operating conditions. To ensure safe dissipation of the minor power loss released to the ambient air, it is important to follow the instructions pertaining to control cabinet installation in the SINAMICS Low Voltage Engineering Manual.

⁷⁾ The value applies to coolants comprising water and a mixture of water and anti-freeze agent.

⁸⁾ The value is valid for water as coolant. [Additional information and notes on other coolants is provided in the SINAMICS Low Voltage Engineering Manual.](#)

⁹⁾ Total of all motor cables. Longer cable lengths for specific configurations are available on request. [For additional information, please refer to the SINAMICS Low Voltage Engineering Manual.](#)

SINAMICS S120 Chassis Format Converter Units

Liquid-cooled units

Motor Modules

Technical specifications (continued)

Line voltage 500 ... 690 V 3 AC DC link voltage 675 ... 1035 V DC		Motor Modules					
		6SL3325-1TG37-4AA3	6SL3325-1TG38-0AA3 ¹⁾	6SL3325-1TG38-1AA3	6SL3325-1TG41-0AA3	6SL3325-1TG41-3AA3	6SL3325-1TG41-6AA3
Rated power							
• At I_L (50 Hz 690 V) ²⁾	kW	710	800	800	1000	1200	1500
• At I_H (50 Hz 690 V) ²⁾	kW	630	710	710	900	1000	1260
• At I_L (50 Hz 500 V) ²⁾	kW	500	560	560	710	900	1000
• At I_H (50 Hz 500 V) ²⁾	kW	450	500	560	630	800	900
• At I_L (60 Hz 575 V) ³⁾	hp	700	800	800	1000	1250	1500
• At I_H (60 Hz 575 V) ³⁾	hp	700	700	700	900	1000	1250
Output current							
• Rated current $I_{rated O}$	A	735	810	810	1025	1270	1560
• Base-load current $I_L^{4)}$	A	710	790	790	1000	1230	1500
• Base-load current $I_H^{5)}$	A	657	724	724	917	1136	1284
• Maximum current $I_{max O}$	A	1065	1185	1185	1500	1845	2055
DC link current							
• Rated current $I_{rated DC}$ when supplied via							
- Basic Line Module	A	903	990	990	1250	1550	1903
- Active Line Module	A	759	891	891	1125	1395	1605
• Base-load current $I_{L DC}^{4)}$ when supplied from							
- Basic Line Module	A	870	948	963	1219	1500	1800
- Active Line Module	A	781	870	869	1100	1353	1650
• Base-load current $I_{H DC}^{5)}$ when supplied from							
- Basic Line Module	A	795	885	883	1118	1384	1680
- Active Line Module	A	732	808	796	1009	1250	1550
Current demand							
• 24 V DC auxiliary power supply	A	1.6	1.6	1.46	1.46	1.46	1.46
DC link capacitance	μF	10500	10500	14000	16000	19330	21000
Pulse frequency⁶⁾							
• Rated frequency	kHz	1.25	1.25	1.25	1.25	1.25	1.25
• Pulse frequency, max.							
- Without current derating	kHz	1.25	1.25	1.25	1.25	1.25	1.25
- With current derating	kHz	7.5	7.5	7.5	7.5	7.5	7.5
Power loss, max.⁷⁾							
• At 50 Hz 690 V	kW	7.65	8.47	9.56	10.87	13.49	17.9
• At 60 Hz 575 V	kW	6.67	7.39	8.34	9.55	11.84	15.7
• Dissipated to ambient air	kW	0.2	0.22	0.43	0.53	0.57	0.78
Coolant volume flow⁸⁾	l/min	16	16	27	27	27	27
Liquid volume of the integrated heat exchanger	dm ³	0.74	0.74	1.56	1.56	1.56	1.56
Pressure drop, typ.⁹⁾ for volume flow	Pa	70000	70000	70000	70000	70000	70000
Heat exchanger material		Aluminum	Aluminum	Aluminum	Aluminum	Aluminum	Aluminum
Sound pressure level L_{pA} (1 m) at 50/60 Hz	dB	54	54	56	56	56	56
DC link connection DCP, DCN		2 × hole for M12 busbar	2 × hole for M12 busbar	2 × hole for M12 busbar	2 × hole for M12 busbar	2 × hole for M12 busbar	2 × hole for M12 busbar
Motor connection U2, V2, W2		2 × hole for M12	2 × hole for M12	2 × hole for M12	2 × hole for M12	2 × hole for M12	2 × hole for M12
• Conductor cross section, max. (IEC)	mm ²	4 × 185	4 × 185	Busbar	Busbar	Busbar	Busbar

SINAMICS S120 Chassis Format Converter Units

Liquid-cooled units

Motor Modules

Technical specifications (continued)

Line voltage 500 ... 690 V 3 AC DC link voltage 675 ... 1035 V DC		Motor Modules					
		6SL3325-1TG37-4AA3	6SL3325-1TG38-0AA3 ¹⁾	6SL3325-1TG38-1AA3	6SL3325-1TG41-0AA3	6SL3325-1TG41-3AA3	6SL3325-1TG41-6AA3
PE/GND connection		2 × hole for M12	2 × hole for M12	2 × hole for M12	2 × hole for M12	2 × hole for M12	2 × hole for M12
• Conductor cross section, max. (IEC)	mm ²	4 × 185	4 × 185	Busbar	Busbar	Busbar	Busbar
Cable length, max.¹⁰⁾							
• Shielded	m	300	300	300	300	300	300
• Unshielded	m	450	450	450	450	450	450
Dimensions							
• Width	mm	265	265	295	295	295	295
• Height	mm	1002	1002	1516	1516	1516	1516
• Depth	mm	545	545	545	545	545	545
Weight, approx.	kg	110	110	220	220	220	230
Frame size		HXL	HXL	JXL	JXL	JXL	JXL

3

- ¹⁾ The device is optimized for a base pulse frequency of 1.25 kHz, for an increased pulse frequency – or for certain overloads the derating factor is higher than that for the device with article number 6SL3325-1TG38-1AAx.
- ²⁾ Rated output of a typical 6-pole standard induction motor based on I_L or I_H for 500 V or 690 V 3 AC 50 Hz.
- ³⁾ Rated output of a typical 6-pole standard induction motor based on I_L or I_H for 575 V 3 AC 60 Hz.
- ⁴⁾ The base-load current I_L is based on a load cycle of 110 % for 60 s or 150 % for 10 s with a load cycle duration of 300 s.
- ⁵⁾ The base-load current I_H is based on a duty cycle of 150 % for 60 s or 160 % for 10 s with a duty cycle duration of 300 s.
- ⁶⁾ Additional notes regarding the correlation between the pulse frequency and maximum output current/output frequency is provided in the SINAMICS Low Voltage Engineering Manual.

- ⁷⁾ The specified power loss represents the maximum value at 100% utilization. The value is lower under normal operating conditions. To ensure safe dissipation of the minor power loss released to the ambient air, it is important to follow the instructions pertaining to control cabinet installation in the SINAMICS Low Voltage Engineering Manual.
- ⁸⁾ The value applies to coolants comprising water and a mixture of water and anti-freeze agent.
- ⁹⁾ The value is valid for water as coolant. [Additional information and notes on other coolants is provided in the SINAMICS Low Voltage Engineering Manual.](#)
- ¹⁰⁾ Sum of all motor cables. Longer cable lengths for specific configurations are available on request. [For additional information, please refer to the SINAMICS Low Voltage Engineering Manual.](#)

SINAMICS S120 Chassis Format Converter Units

System components

Line-side power components

Technical specifications

General technical specifications

Unless clearly specified otherwise, the following technical data are valid for all the following system components of the air-cooled and liquid-cooled SINAMICS S120 drive system in the chassis format.

Electrical specifications			
Rated voltages	380 ... 480 V 3 AC, ±10 % (-15 % <1 min) 500 ... 690 V 3 AC, ±10 % (-15 % <1 min)		
Line supply types	Grounded TN/TT systems and non-grounded IT systems		
Line frequency	47 ... 63 Hz		
Overvoltage category	III to EN 61800-5-1		
Electronics power supply	24 V DC, -15 % +20 % implemented as PELV circuit in accordance with EN 61800-5-1 Ground = negative pole grounded via the electronics		
Mechanical specifications			
Degree of protection	IP00 or IP20 dependent on type		
Protection class	I acc. to EN 61800-5-1		
Touch protection	EN 50274 / BGV A3 when used for the intended purpose		
Ambient conditions	Storage ¹⁾	Transport ¹⁾	Operation
Ambient temperature	-25 ... +55 °C Class 1K4 acc. to EN 60721-3-1	-25 ... +70 °C Class 2K4 acc. to EN 60721-3-2	Line-side components: 0 ... 40 °C without derating Up to 55 °C, see derating data Control Units, supplementary system components, and Sensor Modules: 0 ... 55 °C (for operation in control cabinet) DC link components and motor-side components: 0 ... 55 °C
Relative humidity Condensation, splashwater, and ice formation not permitted (EN 60204, Part 1)	<u>5 ... 95 %</u> Class 1K4 acc. to EN 60721-3-1	5 ... 95 % at 40 °C Class 2K4 acc. to EN 60721-3-2	<u>5 ... 95 %</u> Class 3K3 acc. to EN 60721-3-3
Environmental class/harmful chemical substances	Class 1C2 acc. to EN 60721-3-1	Class 2C2 acc. to EN 60721-3-2	Class 3C2 acc. to EN 60721-3-3
Organic/biological influences	Class 1B1 acc. to EN 60721-3-1	Class 2B1 acc. to EN 60721-3-2	Class 3B1 acc. to EN 60721-3-3
Degree of pollution	2 acc. to EN 61800-5-1	2 acc. to EN 61800-5-1	2 acc. to EN 61800-5-1
Installation altitude	Up to 2000 m above sea level without derating >2000 m above sea level, see derating data		
Mechanical stability	Storage ¹⁾	Transport ¹⁾	Operation
Vibratory load	–	Class 2M2 acc. to EN 60721-3-2	Test values acc. to EN 60068-2-6 test Fc: • 10 ... 58 Hz with constant deflection 0.075 mm • 58 ... 150 Hz with constant acceleration 9.81 m/s ² (1 × g)
Shock load	–	Class 2M2 acc. to EN 60721-3-2	Test values according to EN 60068-2-27 test Ea: 98 m/s ² (10 × g)/20 ms
Compliance with standards			
Conformances/approvals, according to	CE (EMC Directive No. 2004/108/EC, Low Voltage Directive No. 2006/95/EC and Machinery Directive 2006/42/EC for functional safety) cURus or cULus (only for devices connected to line supply voltages 380 ... 480 V 3 AC and 500 ... 600 V 3 AC)		
Radio interference suppression	SINAMICS drive converter systems are not designed for connection to the public grid (first environment). Radio interference suppression is compliant with the EMC product standard for variable-speed drives EN 61800-3, "Second environment" (industrial networks). EMC disturbances can occur when connected to the public power networks. However, if additional measures are taken (e.g. → line filter), it can also be operated in the "first environment".		

Deviations from the specified class are underlined.

¹⁾ In transport packaging.

SINAMICS S120 Chassis Format Converter Units

System components

Line-side power components > Line filter

Overview



In conjunction with line reactors and a logically consistent configuration of the plant or system, line filters limit the interference conducted by the Basic Line Modules and Power Modules to the limit values of Category C2 acc. to EN 61800-3.

The line filters are suitable for TN and TT supply systems grounded at the neutral point.

Selection and ordering data

Line filters for Power Modules

Suitable for Power Module in the chassis format, air-cooled	Type rating of the Power Module at 400 V	Rated input current of the Power Module	Line filter
6SL3310-...	kW	A	Article No.
Line voltage 380 ... 480 V 3 AC			
1TE32-1AA3	110	229	6SL3000-0BE32-5AA0
1TE32-6AA3	132	284	6SL3000-0BE34-4AA0
1TE33-1AA3	160	338	
1TE33-8AA3	200	395	
1TE35-0AA3	250	509	6SL3000-0BE36-0AA0

Line filters for Basic Line Modules

Suitable for Basic Line Module chassis format, air-cooled	Rated power of the Basic Line Module at 400 V or 690 V	Rated input current of the Basic Line Module	Line filter
6SL3330-...	kW	A	Article No.
Line voltage 380 ... 480 V 3 AC			
1TE34-2AA3	200	365	6SL3000-0BE34-4AA0
1TE35-3AA3	250	460	6SL3000-0BE36-0AA0
1TE38-2AA3	400	710	6SL3000-0BE41-2AA0
1TE41-2AA3	560	1010	
1TE41-5AA3	710	1265	6SL3000-0BE41-6AA0
1TE41-8AA3	900	1581	
Line voltage 500 ... 690 V 3 AC			
1TG33-0AA3	250	260	6SL3000-0BG34-4AA0
1TG34-3AA3	355	375	
1TG36-8AA3	560	575	6SL3000-0BG36-0AA0
1TG41-1AA3	900	925	6SL3000-0BG41-2AA0
1TG41-4AA3	1100	1180	
7TG41-8AA3	1500	1580	6SL3000-0BG41-6AA0

SINAMICS S120 Chassis Format Converter Units

System components

Line-side power components > Line filter

Selection and ordering data (continued)

Line filters for Smart Line Modules

Suitable for Smart Line Module in chassis format, air-cooled 6SL3330-...	Rated power of the Smart Line Module at 400 V or 690 V kW	Rated input current of the Smart Line Module A	Line filter Article No.
Line voltage 380 ... 480 V 3 AC			
6TE35-5AA3	250	463	6SL3000-0BE35-0AA0
6TE37-3AA3	355	614	6SL3760-0MB00-0AA0
6TE41-1AA3	500	883	6SL3760-0MC00-0AA0
6TE41-3AA3	630	1093	
6TE41-7AA3	800	1430	
Line voltage 500 ... 690 V 3 AC			
6TG35-5AA3	450	463	6SL3760-0ME00-0AA0
6TG38-8AA3	710	757	6SL3760-0MN00-0AA0
6TG41-2AA3	1000	1009	6SL3760-0MG00-0AA0
6TG41-7AA3	1400	1430	

Line filters for Active Line Modules

Suitable for Active Line Module chassis format, air-cooled 6SL3330-...	Rated power of the Active Line Module at 400 V or 690 V kW	Rated input current of the Active Line Module A	Line filter Article No.	
Line voltage 380 ... 480 V 3 AC				
7TE32-1AA3	132	210	6SL3000-0BE33-1AA0	
7TE32-6AA3	160	260	6SL3000-0BE35-0AA0	
7TE33-8AA3	235	380		
7TE35-0AA3	300	490	6SL3760-0MB00-0AA0	
7TE36-1AA3	380	605		
7TE37-5AA3	450	745	6SL3760-0MC00-0AA0	
7TE38-4AA3	500	840		
7TE41-0AA3	630	985		
7TE41-2AA3	800	1260		
7TE41-4AA3	900	1405	6SL3760-0MG00-0AA0	
Line voltage 500 ... 690 V 3 AC				
7TG35-8AA3	630	575		6SL3760-0ME00-0AA0
7TG37-4AA3	800	735		6SL3760-0MN00-0AA0
7TG41-0AA3	1100	1025		6SL3760-0MG00-0AA0
7TG41-3AA3	1400	1270		

Note:

Line filters are not available for liquid-cooled drive units.

SINAMICS S120 Chassis Format Converter Units

System components

Line-side power components > Line filter

Technical specifications

Line voltage 380 ... 480 V 3 AC		Line filter				
		6SL3000-0BE32-5AA0	6SL3000-0BE34-4AA0	6SL3000-0BE36-0AA0	6SL3000-0BE41-2AA0	6SL3000-0BE41-6AA0
Rated current	A	250	440	600	1200	1600
Power loss ¹⁾ At 50 Hz	kW	0.015	0.047	0.053	0.119	0.153
Load/line supply connection		1 × hole for M10 Provided for busbar connection	1 × hole for M10 Provided for busbar connection	1 × hole for M10 Provided for busbar connection	1 × hole for M12 Provided for busbar connection	1 × hole for M12 Provided for busbar connection
PE connection		Hole for M8	Hole for M8	Hole for M10	Hole for M10	Hole for M10
Degree of protection		IP00	IP00	IP00	IP00	IP00
Dimensions						
• Width	mm	360	360	400	425	505
• Height	mm	240	240	265	265	265
• Depth	mm	116	116	140	145	145
Weight, approx.	kg	12.3	12.3	19	25.2	28.8
Suitable for Power Module in the chassis format						
• Air-cooled (type rating)	6SL3310-...	1TE32-1AA3 (110 kW)	1TE32-6AA3 (132 kW) 1TE33-1AA3 (160 kW) 1TE33-8AA3 (200 kW)	1TE35-0AA3 (250 kW)	–	–
Suitable for Basic Line Module in chassis format						
• Air-cooled (rated power)	6SL3330-...	–	1TE34-2AA3 (200 kW)	1TE35-3AA3 (250 kW)	1TE38-2AA3 (400 kW) 1TE41-2AA3 (560 kW)	1TE41-5AA3 (710 kW) 1TE41-8AA3 (900 kW)
Line voltage 500 ... 690 V 3 AC		Line filter				
		6SL3000-0BG34-4AA0	6SL3000-0BG36-0AA0	6SL3000-0BG41-2AA0	6SL3000-0BG41-6AA0	
Rated current	A	440	600	1200	1600	
Power loss ¹⁾ At 50 Hz	kW	0.047	0.053	0.119	0.153	
Load/line supply connection		1 × hole for M10 Provided for busbar connection	1 × hole for M10 Provided for busbar connection	2 × hole for M12 Provided for busbar connection	2 × hole for M12 Provided for busbar connection	
PE connection		Hole for M8	Hole for M10	Hole for M10	Hole for M10	
Degree of protection		IP00	IP00	IP00	IP00	
Dimensions						
• Width	mm	360	400	425	505	
• Height	mm	240	265	265	265	
• Depth	mm	116	140	145	145	
Weight, approx.	kg	12.3	19	25.2	28.8	
Suitable for Basic Line Module in chassis format						
• Air-cooled (rated power)	6SL3330-...	1TG33-0AA3 (250 kW) 1TG34-3AA3 (355 kW)	1TG36-8AA3 (560 kW)	1TG41-1AA3 (900 kW) 1TG41-4AA3 (1100 kW)	1TG41-8AA3 (1500 kW)	

¹⁾ The specified power loss represents the maximum value at 100% utilization. The value is lower under normal operating conditions.

SINAMICS S120 Chassis Format Converter Units

System components

Line-side power components > Line filter

Technical specifications (continued)

Line voltage 380 ... 480 V 3 AC		Line filter			
		6SL3000-0BE33-1AA0	6SL3000-0BE35-0AA0	6SL3760-0MB00-0AA0	6SL3760-0MC00-0AA0
Rated current	A	400	600	840	1405
Power loss ¹⁾ At 50 Hz	kW	0.042	0.06	0.058	0.111
Load/line supply connection		M10 connecting lugs	M10 connecting lugs	M10 connecting lugs	M10 connecting lugs
PE connection		Hole for M8	Hole for M10	Hole for M10	Hole for M10
Degree of protection		IP00	IP00	IP00	IP00
Dimensions					
• Width	mm	360	390	425	505
• Height	mm	240	265	265	265
• Depth	mm	116	140	145	145
Weight, approx.	kg	12.7	19.9	25.9	28.9
Suitable for Smart Line Module in chassis format					
• Air-cooled (rated power)	6SL3330-...	–	6TE35-5AA3 (250 kW)	6TE37-3AA3 (355 kW)	6TE41-1AA3 (500 kW) 6TE41-3AA3 (630 kW) 6TE41-7AA3 (800 kW)
Suitable for Active Line Module in chassis format					
• Air-cooled (rated power)	6SL3330-...	7TE32-1AA3 (132 kW) 7TE32-6AA3 (160 kW)	7TE33-8AA3 (235 kW) 7TE35-0AA3 (300 kW)	7TE36-1AA3 (380 kW) 7TE37-5AA3 (450 kW)	7TE38-4AA3 (500 kW) 7TE41-0AA3 (630 kW) 7TE41-2AA3 (800 kW) 7TE41-4AA3 (900 kW)
Line voltage 500 ... 690 V 3 AC		Line filter			
		6SL3760-0ME00-0AA0	6SL3760-0MN00-0AA0	6SL3760-0MG00-0AA0	
Rated current	A	600	1025	1270	
Power loss ¹⁾ At 50 Hz	kW	0.063	0.063	0.097	
Load/line supply connection		M10 connecting lugs	M12 connecting lugs	M12 connecting lugs	
PE connection		Hole for M10	Hole for M10	Hole for M10	
Degree of protection		IP00	IP00	IP00	
Dimensions					
• Width	mm	400	425	505	
• Height	mm	365	365	365	
• Depth	mm	140	145	145	
Weight, approx.	kg	27	36.7	36.7	
Suitable for Smart Line Module in chassis format					
• Air-cooled (rated power)	6SL3330-...	6TG35-5AA3 (450 kW)	6TG38-8AA3 (710 kW) 6TG41-2AA3 (1000 kW)	6TG41-7AA3 (1400 kW)	
Suitable for Active Line Module in chassis format					
• Air-cooled (rated power)	6SL3330-...	7TG35-8AA3 (630 kW)	7TG37-4AA3 (800 kW) 7TG41-0AA3 (1100 kW)	7TG41-3AA3 (1400 kW)	

¹⁾ The specified power loss represents the maximum value at 100% utilization. The value is lower under normal operating conditions.

SINAMICS S120 Chassis Format Converter Units

System components

Line-side power components > Line reactors

Overview

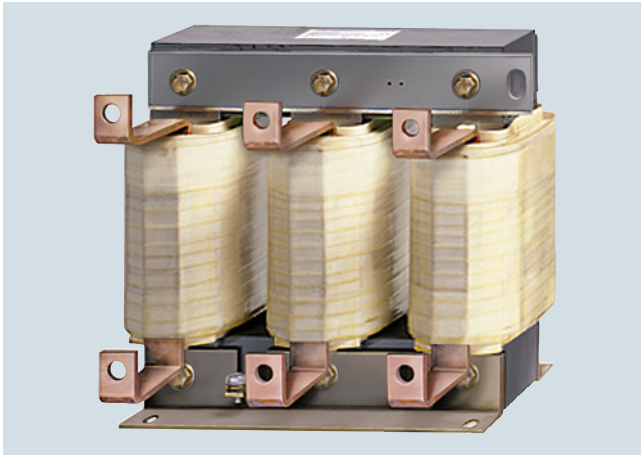

With a high line short-circuit power (i.e. low line supply cable inductance) a line reactor is required in order to

- protect the drive converter itself from excessively high harmonic currents and therefore overload
- limit the harmonics to permissible values. The harmonic currents are limited by the complete inductance comprising the line reactor and line supply cable inductance.

For additional information, please refer to the [SINAMICS Low Voltage Engineering Manual](#).

3

Selection and ordering data

Line reactors for SINAMICS S120 Power Modules

Suitable for Power Module in the chassis format, <u>air-cooled</u>	Suitable for Power Module in the chassis format, <u>liquid-cooled</u>	Type rating of the Power Modules at 400 V	Rated input current of the Power Module	Line reactor
6SL3310-...	6SL3315-...	kW	A	Article No.
Line voltage 380 ... 480 V 3 AC				
1TE32-1AA3	1TE32-1AA3	110	229/230	6SL3000-OCE32-3AA0
1TE32-6AA3	1TE32-6AA3	132	284/285	6SL3000-OCE32-8AA0
1TE33-1AA3	1TE33-1AA3	160	338/340	6SL3000-OCE33-3AA0
1TE33-8AA3	–	200	395	6SL3000-OCE35-1AA0
1TE35-0AA3	1TE35-0AA3	250	509/540	

Line reactors for SINAMICS S120 Basic Line Modules

Suitable for Basic Line Module chassis format, <u>air-cooled</u>	Suitable for Basic Line Module chassis format, <u>liquid-cooled</u>	Rated power of the Basic Line Module at 400 V or 690 V	Rated input current of the Basic Line Module	Line reactor
6SL3330-...	6SL3335-...	kW	A	Article No.
Line voltage 380 ... 480 V 3 AC				
1TE34-2AA3	–	200	365	6SL3000-OCE35-1AA0
1TE35-3AA3	–	250	460	
–	1TE37-4AA3	360	610	6SL3000-OCE36-3AA0
1TE38-2AA3	–	400	710	6SL3000-OCE37-7AA0
1TE41-2AA3	–	560	1010	6SL3000-OCE41-0AA0
–	1TE41-2AA3	600	1000	
1TE41-5AA3	–	710	1265	6SL3000-OCE41-5AA0
–	1TE41-7AA3	830	1420	
1TE41-8AA3	–	900	1581	6SL3000-OCE41-6AA0
Line voltage 500 ... 690 V 3 AC				
1TG33-0AA3	–	250	260	6SL3000-OCH32-7AA0
–	1TG34-2AA3	355	340	6SL3000-OCH33-4AA0
1TG34-3AA3	–	355	375	6SL3000-OCH34-8AA0
1TG36-8AA3	–	560	575	6SL3000-OCH36-0AA0
–	1TG37-3AA3	630	600	
1TG41-1AA3	–	900	925	6SL3000-OCH41-2AA0
–	1TG41-3AA3	1100	1070	
1TG41-4AA3	–	1100	1180	
–	1TG41-7AA3	1370	1350	6SL3000-OCH41-6AA0
1TG41-8AA3	–	1500	1580	

SINAMICS S120 Chassis Format Converter Units

System components

Line-side power components > Line reactors

Selection and ordering data (continued)

Line reactors for SINAMICS S120 Smart Line Modules

Suitable for Smart Line Module in chassis format 6SL3330-...	Rated power of the Smart Line Module at 400 V or 690 V kW	Rated input current of the Smart Line Module A	Line reactor Article No.
Line voltage 380 ... 480 V 3 AC			
6TE35-5AA3	250	463	6SL3000-0EE36-2AA0
6TE37-3AA3	355	614	
6TE41-1AA3	500	883	6SL3000-0EE38-8AA0
6TE41-3AA3	630	1093	6SL3000-0EE41-4AA0
6TE41-7AA3	800	1430	
Line voltage 500 ... 690 V 3 AC			
6TG35-5AA3	450	463	6SL3000-0EH34-7AA0
6TG38-8AA3	710	757	6SL3000-0EH37-6AA0
6TG41-2AA3	1000	1009	6SL3000-0EH41-4AA0
6TG41-7AA3	1400	1430	

Technical specifications

Line voltage 380 ... 480 V 3 AC		Line reactor					
		6SL3000-0CE32-3AA0	6SL3000-0CE32-8AA0	6SL3000-0CE33-3AA0	6SL3000-0CE35-1AA0	6SL3000-0CE36-3AA0	6SL3000-0CE37-7AA0
Rated current	A	224	278	331	508	628	773
Nominal inductance L_N	μH	76	62	52	42	27	22
Power loss ¹⁾ At 50 Hz	kW	0.274	0.247	0.267	0.365	0.368	0.351
Line/load connection		1 × hole for M10 Provided for busbar connection	1 × hole for M10 Provided for busbar connection	1 × hole for M10 Provided for busbar connection	1 × hole for M12 Provided for busbar connection	1 × hole for M12 Provided for busbar connection	1 × hole for M12 Provided for busbar connection
PE connection		M6 screw	M6 screw	M6 screw	M6 screw	M6 screw	M6 screw
Degree of protection		IP00	IP00	IP00	IP00	IP00	IP00
Dimensions							
• Width	mm	270	270	270	300	300	300
• Height	mm	248	248	248	269	269	269
• Depth	mm	200	200	200	212	212	212
Weight, approx.	kg	24.5	26	27.8	38	41.4	51.3
Suitable for Power Module in the chassis format							
• Air-cooled (type rating)	6SL3310-...	1TE32-1AA3 (110 kW)	1TE32-6AA3 (132 kW)	1TE33-1AA3 (160 kW)	1TE33-8AA3 (200 kW) 1TE35-0AA3 (250 kW)	–	–
• Liquid cooled (type rating)	6SL3315-...	1TE32-1AA3 (110 kW)	1TE32-6AA3 (132 kW)	1TE33-1AA3 (160 kW)	1TE35-0AA3 (250 kW)	–	–
Suitable for Basic Line Module in chassis format							
• Air-cooled (rated power)	6SL3330-...	–	–	–	1TE34-2AA3 (200 kW) 1TE35-3AA3 (250 kW)	–	1TE38-2AA3 (400 kW)
• Liquid-cooled (rated power)	6SL3335-...	–	–	–	–	1TE37-4AA3 (360 kW)	–

¹⁾ The specified power loss represents the maximum value at 100% utilization. The value is lower under normal operating conditions.

SINAMICS S120 Chassis Format Converter Units

System components

Line-side power components > Line reactors

Technical specifications (continued)

Line voltage 380 ... 480 V 3 AC		Line reactor		
		6SL3000-0CE41-0AA0	6SL3000-0CE41-5AA0	6SL3000-0CE41-6AA0
Rated current	A	1022	1485	1600
Nominal inductance L_N	μH	16	13	13
Power loss ¹⁾ At 50 Hz	kW	0.498	0.776	0.606
Line/load connection		1 × hole for M12 Provided for busbar connection	1 × hole for M12 Provided for busbar connection	1 × hole for M12 Provided for busbar connection
PE connection		M6 screw	M6 screw	M6 screw
Degree of protection		IP00	IP00	IP00
Dimensions				
• Width	mm	350	460	416
• Height	mm	321	435	435
• Depth	mm	211	235	235
Weight, approx.	kg	69.6	118	123
Suitable for Basic Line Module in chassis format				
• Air-cooled (rated power)	6SL3330-...	1TE41-2AA3 (560 kW)	1TE41-5AA3 (710 kW)	1TE41-8AA3 (900 kW)
• Liquid-cooled (rated power)	6SL3335-...	1TE41-2AA3 (600 kW)	1TE41-7AA3 (830 kW)	–
Line voltage 380 ... 480 V 3 AC		Line reactor		
		6SL3000-0EE36-2AA0	6SL3000-0EE38-8AA0	6SL3000-0EE41-4AA0
Rated current	A	615	885	1430
Nominal inductance L_N	μH	55	35	25
Power loss ¹⁾ At 50 Hz	kW	0.56	0.81	1.08
Line/load connection		1 × hole for M10 Provided for busbar connection	1 × hole for M10 Provided for busbar connection	2 × hole for M10 Provided for busbar connection
PE connection		M6 thread	M6 thread	M6 thread
Degree of protection		IP00	IP00	IP00
Dimensions				
• Width	mm	300	442	544
• Height	mm	264	376	386
• Depth	mm	203	263	232
Weight, approx.	kg	57	85.5	220
Suitable for Smart Line Module in chassis format				
• Air-cooled (rated power)	6SL3330-...	6TE35-5AA3 (250 kW) 6TE37-3AA3 (355 kW)	6TE41-1AA3 (500 kW)	6TE41-3AA3 (630 kW) 6TE41-7AA3 (800 kW)

¹⁾ The specified power loss represents the maximum value at 100% utilization. The value is lower under normal operating conditions.

SINAMICS S120 Chassis Format Converter Units

System components

Line-side power components > Line reactors

Technical specifications (continued)

Line voltage 500 ... 690 V 3 AC		Line reactor					
		6SL3000-0CH32-7AA0	6SL3000-0CH33-4AA0	6SL3000-0CH34-8AA0	6SL3000-0CH36-0AA0	6SL3000-0CH41-2AA0	6SL3000-0EH41-6AA0
Rated current	A	270	342	482	597	1167	1600
Nominal inductance L_N	μH	100	81	65	46	30	17
Power loss ¹⁾ At 50 Hz	kW	0.277	0.27	0.48	0.485	0.783	0.977
Line/load connection		1 × hole for M10 Provided for busbar connection	1 × hole for M10 Provided for busbar connection	1 × hole for M12 Provided for busbar connection	1 × hole for M12 Provided for busbar connection	2 × hole for M12 Provided for busbar connection	2 × hole for M12 Provided for busbar connection
PE connection		M6 screw	M6 screw	M6 screw	M6 screw	M6 screw	M6 screw
Degree of protection		IP00	IP00	IP00	IP00	IP00	IP00
Dimensions							
• Width	mm	270	270	350	350	460	416
• Height	mm	248	248	321	321	435	435
• Depth	mm	200	200	232	232	235	250
Weight, approx.	kg	27.9	38.9	55.6	63.8	147	134
Suitable for Basic Line Module in chassis format							
• Air-cooled (rated power)	6SL3330-...	1TG33-0AA3 (250 kW)	–	1TG34-3AA3 (355 kW)	1TG36-8AA3 (560 kW)	1TG41-1AA3 (900 kW) 1TG41-4AA3 (1100 kW)	1TG41-8AA3 (1500 kW)
• Liquid-cooled (rated power)	6SL3335-...	–	1TG34-2AA3 (355 kW)	–	1TG37-3AA3 (630 kW)	1TG41-3AA3 (1100 kW)	1TG41-7AA3 (1370 kW)
Line voltage 500 ... 690 V 3 AC		Line reactor					
		6SL3000-0EH34-7AA0		6SL3000-0EH37-6AA0		6SL3000-0EH41-4AA0	
Rated current	A	465		760		1430	
Nominal inductance L_N	μH	115		70		40	
Power loss ¹⁾ At 50 Hz	kW	0.82		0.95		1.85	
Line/load connection		1 × hole for M10 Provided for busbar connection		1 × hole for M10 Provided for busbar connection		2 × hole for M10 Provided for busbar connection	
PE connection		M6 nut		M6 nut		M6 nut	
Degree of protection		IP00		IP00		IP00	
Dimensions							
• Width	mm	360		442		655	
• Height	mm	325		370		383	
• Depth	mm	229		303		288	
Weight, approx.	kg	58		145		239	
Suitable for Smart Line Module in chassis format							
• Air-cooled (rated power)	6SL3330-...	6TG35-5AA3 (450 kW)		6TG38-8AA3 (710 kW)		6TG41-2AA3 (1000 kW) 6TG41-7AA3 (1400 kW)	

¹⁾ The specified power loss represents the maximum value at 100% utilization. The value is lower under normal operating conditions.

SINAMICS S120 Chassis Format Converter Units

System components

Line-side power components > Recommended line-side system components

Overview

Appropriate line-side power components are assigned depending on the power rating of the Power Modules, Basic Line Modules, Smart Line Modules or Active Line Modules.

Further information about the main contactors, switch disconnectors, fuses and circuit breakers is provided in the Catalogs IC 10 and LV 10.

Assignment of line-side power components to air-cooled and liquid-cooled Power Modules in chassis format

Type rating at 400 V	Rated input current		Suitable for Power Module in the chassis format	Main contactor		Switch disconnector without handle and shaft		Switch disconnector with handle and shaft	
	Air-cooled	Liquid-cooled		Article No.	Article No.	Article No.	Article No.		
kW	A	A	6SL3310-... ¹⁾ 6SL3315-... ²⁾	Article No.	Article No.	Article No.	Article No.	Article No.	Article No.
Line voltage 380 ... 480 V 3 AC									
110	229	230	1TE32-1AA3	3RT1064-6AP36	3KL5530-1AB01	3KL5530-1GB01			
132	284	285	1TE32-6AA3	3RT1065-6AP36	3KL5730-1AB01	3KL5730-1GB01			
160	338	340	1TE33-1AA3	3RT1066-6AP36	–				
200	395	–	1TE33-8AA3	3RT1075-6AP36	–				
250	509	540	1TE35-0AA3	3RT1076-6AP36	3KL6130-1AB02	3KL6130-1GB02			

Type rating at 400 V	Rated input current		Suitable for Power Module in the chassis format	Cable protection fuse		Cable protection fuse incl. semiconductor protection	
	Air-cooled	Liquid-cooled		Rated current	Article No.	Rated current	Article No.
kW	A	A	6SL3310-... ¹⁾ 6SL3315-... ²⁾	A	Article No.	A	Article No.
Line voltage 380 ... 480 V 3 AC							
110	229	230	1TE32-1AA3	250	3NA3144	315	3NE1230-2
132	284	285	1TE32-6AA3	300	3NA3250	350	3NE1331-2
160	338	340	1TE33-1AA3	355	3NA3254	450	3NE1333-2
200	395	–	1TE33-8AA3	400	3NA3260		
250	509	540	1TE35-0AA3	630	3NA3372	2 × 315/630	3NE1230-2 or 3NE1436-2

¹⁾ 6SL3310-... is the air-cooled version.

²⁾ 6SL3315-... is the liquid-cooled version.

SINAMICS S120 Chassis Format Converter Units

System components

Line-side power components > Recommended line-side system components

Overview (continued)

Assignment of line-side power components to air-cooled and liquid-cooled Basic Line Modules in chassis format

Rated power at 400 V or 690 V kW	Rated input current A	Suitable for Basic Line Module	Main contactor Article No.	Fixed-mounted circuit breaker Article No.	Switch disconnecter without handle and shaft Article No.	Switch disconnecter with handle and shaft Article No.
Line voltage 380 ... 480 V 3 AC						
200	365	6SL3330-1TE34-2AA3 ¹⁾	3RT1075-...	–	3KL6130-1AB02	3KL6130-1GB02
250	460	6SL3330-1TE35-3AA3 ¹⁾	3RT1076-...	–	3KL6130-1AB02	3KL6130-1GB02
360	610	6SL3335-1TE37-4AA3 ²⁾	3RT1076-...	–	3KL6130-1AB02	3KL6130-1GB02
400	710	6SL3330-1TE38-2AA3 ¹⁾	3RT1066-... (3 units)	–	3KL6230-1AB02	3KL6230-1GB02 ³⁾
560	1010	6SL3330-1TE41-2AA3 ¹⁾	–	3WL1112-2BB34-4AN2-Z C22 ⁴⁾	–	–
600	1000	6SL3335-1TE41-2AA3 ²⁾	–	3WL1112-2BB34-4AN2-Z C22 ⁴⁾	–	–
710	1265	6SL3330-1TE41-5AA3 ¹⁾	–	3WL1116-2BB34-4AN2-Z C22 ⁴⁾	–	–
830	1420	6SL3335-1TE41-7AA3 ²⁾	–	3WL1116-2BB34-4AN2-Z C22 ⁴⁾	–	–
900	1630	6SL3330-1TE41-8AA3 ¹⁾	–	3WL1220-2BB34-4AN2-Z C22 ⁴⁾	–	–
Line voltage 500 ... 690 V 3 AC						
250	260	6SL3330-1TG33-0AA3 ¹⁾	3RT1066-...	–	3KL5730-1AB01	3KL5730-1GB01
355	375	6SL3330-1TG34-3AA3 ¹⁾	3RT1075-...	–	3KL6130-1AB02	3KL6130-1GB02
	340	6SL3335-1TG34-2AA3 ²⁾				
560	575	6SL3330-1TG36-8AA3 ¹⁾	3RT1076-...	–	3KL6130-1AB02	3KL6130-1GB02
630	600	6SL3335-1TG37-3AA3 ²⁾	3RT1076-...	–	3KL6130-1AB02	3KL6130-1GB02
900	925	6SL3330-1TG41-1AA3 ¹⁾	–	3WL1210-4BB34-4AN2-Z C22 ⁴⁾	–	–
1100	1180	6SL3330-1TG41-4AA3 ¹⁾	–	3WL1212-4BB34-4AN2-Z C22 ⁴⁾	–	–
	1070	6SL3335-1TG41-3AA3 ²⁾				
1370	1350	6SL3335-1TG41-7AA3 ²⁾	–	3WL1216-4BB34-4AN2-Z C22 ⁴⁾	–	–
1500	1580	6SL3330-1TG41-8AA3 ¹⁾	–	3WL1220-4BB34-4AN2-Z C22 ⁴⁾	–	–

¹⁾ 6SL3330-... is the air-cooled version.

²⁾ 6SL3335-... is the liquid-cooled version.

³⁾ Suitable only for 3NE1 fuses up to size 3.

⁴⁾ The breakers must always be switched ON and OFF by the sequence control. An interlocking set 3WL9111-0BA21-0AA0 as described in Catalog LV 10 should be provided for the circuit breakers in order to exclude the risk of unintentional manual operation. Manual operation bypasses the pre-charging circuit and can therefore destroy the Line Module.

SINAMICS S120 Chassis Format Converter Units

System components

Line-side power components > Recommended line-side system components

Overview (continued)

Rated power at 400 V or 690 V kW	Rated input current A	Suitable for Basic Line Module 6SL3330-...	Cable protection fuse		Cable protection fuse incl. semiconductor protection	
			Rated current A	Article No.	Rated current A	Article No.
Line voltage 380 ... 480 V 3 AC						
200	365	6SL3330-1TE34-2AA3 ¹⁾	500	3NA3365	450	3NE1333-2
250	460	6SL3330-1TE35-3AA3 ¹⁾	630	3NA3372	500	3NE1334-2
360	610	6SL3335-1TE37-4AA3 ²⁾	2 × 315	3NA3352 (2 units)	2 × 450	3NE1333-2 (2 units)
400	710	6SL3330-1TE38-2AA3 ¹⁾	800	3NA3475	800	3NE1438-2
560	1010	6SL3330-1TE41-2AA3 ¹⁾	1250	3NA3482	2 × 560	3NE1435-2 (2 units)
600	1000	6SL3335-1TE41-2AA3 ²⁾	2 × 500	3NA3365 (2 units)	2 × 560	3NE1435-2 (2 units)
710	1265	6SL3330-1TE41-5AA3 ¹⁾	2 × 800	3NA3475 (2 units)	2 × 710	3NE1437-2 (2 units)
830	1420	6SL3335-1TE41-7AA3 ²⁾	3 × 500	3NA3365 (3 units)	2 × 800	3NE1438-2 (2 units)
900	1630	6SL3330-1TE41-8AA3 ¹⁾	3 × 630	3NA3372 (3 units)	3 × 630	3NE1436-2 (3 units)
Line voltage 500 ... 690 V 3 AC						
250	260	6SL3330-1TG33-0AA3 ¹⁾	315	3NA3252-6	315	3NE1230-2
355	375	6SL3330-1TG34-3AA3 ¹⁾	500	3NA3365-6	450	3NE1333-2
	340	6SL3335-1TG34-2AA3 ²⁾	355	3NA3354-6		
560	575	6SL3330-1TG36-8AA3 ¹⁾	2 × 315	3NA3252-6 (2 units)	630	3NE1436-2
630	600	6SL3335-1TG37-3AA3 ²⁾	2 × 300	3NA3250-6 (2 units)	2 × 350	3NE1331-2 (2 units)
900	925	6SL3330-1TG41-1AA3 ¹⁾	2 × 500	3NA3365-6 (2 units)	2 × 500	3NE1334-2 (2 units)
1100	1180	6SL3330-1TG41-4AA3 ¹⁾	3 × 500	3NA3365-6 (3 units)	2 × 630	3NE1436-2 (2 units)
	1070	6SL3335-1TG41-3AA3 ²⁾	3 × 400	3NA3360-6 (3 units)		
1370	1350	6SL3335-1TG41-7AA3 ²⁾	3 × 500	3NA3365-6 (3 units)	3 × 560	3NE1435-2 (3 units)
1500	1580	6SL3330-1TG41-8AA3 ¹⁾	4 × 500	3NA3365-6 (4 units)	3 × 630	3NE1436-2 (3 units)

Power components for the pre-charging circuit of the Basic Line Module in chassis format, frame size GD

Rated power at 400 V or 690 V kW	Rated input current A	Suitable for Basic Line Module 6SL3330-...	Pre-charging resistors		Pre-charging contactor	Cable protection fuse for pre-charging arm	
			Pre-charging current ³⁾ A	Article No.		Article No.	Rated current A
Line voltage 380 ... 480 V 3 AC							
900	1630	1TE41-8AA3	91 ⁴⁾	6SL3000-OKE12-2AA0	3RT1034-... ⁴⁾ 3RT1044-... ⁵⁾	50	3NE1817-0 ⁴⁾ 3NE1021-0 ⁵⁾
			182 ⁵⁾			100	
Line voltage 500 ... 690 V 3 AC							
1500	1580	1TG41-8AA3	86 ⁴⁾ 172 ⁵⁾	6SL3000-OKH14-0AA0	3RT1034-... ⁴⁾ 3RT1044-... ⁵⁾	50 100	3NE1817-0 ⁴⁾ 3NE1021-0 ⁵⁾

Note:

The dimension drawings of the pre-charging resistors are to be found in the dimension drawing collection for Catalog D 21.3 in the Information and Download Center (www.siemens.com/industry/infocenter).

¹⁾ 6SL3330-... is the air-cooled version.

²⁾ 6SL3335-... is the liquid-cooled version.

³⁾ Line current present at the start of the pre-charging process (initial rms value).

⁴⁾ With one pre-charging resistor per phase.

⁵⁾ With two pre-charging resistors connected in parallel per phase.

SINAMICS S120 Chassis Format Converter Units

System components

Line-side power components > Recommended line-side system components

Overview (continued)

Assignment of line-side power components to Smart Line Modules in chassis format

Rated power at 400 V or 690 V kW	Rated input current A	Suitable for Smart Line Module 6SL3330-...	Main contactor		Fixed-mounted circuit breaker		Switch disconnecter without handle and shaft		Switch disconnecter with handle and shaft	
			Article No.		Article No.		Article No.		Article No.	
Line voltage 380 ... 480 V 3 AC										
250	463	6TE35-5AA3	3RT1476-6AP36					3KL6130-1AB02		3KL6130-1GB02
355	614	6TE37-3AA3	3RT1476-6AP36					3KL6230-1AB02		3KL6230-1GB02
500	883	6TE41-1AA3				3WL1210-4CB34-4AN2-Z C22¹⁾				
630	1093	6TE41-3AA3				3WL1212-4CB34-4AN2-Z C22¹⁾				
800	1430	6TE41-7AA3				3WL1216-4CB34-4AN2-Z C22¹⁾				
Line voltage 500 ... 690 V 3 AC										
450	463	6TG35-5AA3	3RT1466-6AP36					3KL6130-1AB02		3KL6130-1GB02
710	757	6TG38-8AA3	3RT1466-6AP36 (3 units)					3KL6230-1AB02		3KL6230-1GB02
1000	1009	6TG41-2AA3				3WL1212-4CB34-4AN2-Z C22¹⁾				
1400	1430	6TG41-7AA3				3WL1216-4CB34-4AN2-Z C22¹⁾				

Rated power at 400 V or 690 V kW	Rated input current A	Suitable for Smart Line Module 6SL3330-...	Cable protection fuse			Cable protection fuse incl. semiconductor protection		
			Rated current A	Article No.		Rated current A	Article No.	
Line voltage 380 ... 480 V 3 AC								
250	463	6TE35-5AA3	500	3NA3365		560		3NE1435-2
355	614	6TE37-3AA3	630	3NA3372		710		3NE1437-2
500	883	6TE41-1AA3	1000	3NA3480		2 × 500		3NE1334-2 (2 units)
630	1093	6TE41-3AA3	1250	3NA3482		2 × 630		3NE1436-2 (2 units)
800	1430	6TE41-7AA3	2 × 800	3NA3475 (2 units)		2 × 850		3NE1448-2 (2 units)
Line voltage 500 ... 690 V 3 AC								
450	463	6TG35-5AA3	500	3NA3365-6		560		3NE1435-2
710	757	6TG38-8AA3	2 × 400	3NA3360-6 (2 units)		850		3NE1448-2
1000	1009	6TG41-2AA3	3 × 355	3NA3354-6 (3 units)		2 × 560		3NE1435-2 (2 units)
1400	1430	6TG41-7AA3	3 × 500	3NA3365-6 (3 units)		2 × 850		3NE1448-2 (2 units)

¹⁾ The breakers must always be switched ON and OFF by the sequence control. An interlocking set 3WL9111-0BA21-0AA0 as described in Catalog LV 10 should be provided for the circuit breakers in order to exclude the risk of unintentional manual operation. Manual operation bypasses the pre-charging circuit and can therefore destroy the Line Module.

SINAMICS S120 Chassis Format Converter Units

System components

Line-side power components > Recommended line-side system components

Overview (continued)

Assignment of line-side power components to air-cooled and liquid-cooled Active Line Modules or Active Interface Modules in chassis format

Rated power at 400 V or 690 V kW	Rated input current A	Suitable for Active Interface Module	Suitable for Active Line Module	Bypass contactor Article No.
Line voltage 380 ... 480 V 3 AC				
132	210	6SL3300-7TE32-6AA0	6SL3330-7TE32-1AA3	Included in Active Interface Module
160	260	6SL3300-7TE32-6AA0	6SL3330-7TE32-6AA3	Included in Active Interface Module
235	380	6SL3300-7TE33-8AA0	6SL3330-7TE33-8AA3	Included in Active Interface Module
300	490	6SL3300-7TE35-0AA0	6SL3330-7TE35-0AA3 6SL3335-7TE35-0AA3	Included in Active Interface Module
380	605	6SL3300-7TE38-4AA0	6SL3330-7TE36-1AA3 6SL3335-7TE36-0AA3	3RT1476-6AP36
500	840	6SL3300-7TE38-4AA0	6SL3330-7TE38-4AA3 6SL3335-7TE38-4AA3	3WL1110-2BB34-4AN2-Z C22¹⁾
630	985	6SL3300-7TE41-4AA0	6SL3330-7TE41-0AA3 6SL3335-7TE41-0AA3	3WL1112-2BB34-4AN2-Z C22¹⁾
800	1260	6SL3300-7TE41-4AA0	6SL3330-7TG37-4AA3	3WL1116-2BB34-4AN2-Z C22¹⁾
900	1405	6SL3300-7TE41-4AA0 6SL3305-7TE41-4AA3	6SL3330-7TE41-4AA3 6SL3335-7TE41-4AA3	3WL1116-2BB34-4AN2-Z C22¹⁾
Line voltage 500 ... 690 V 3 AC				
630	575	6SL3300-7TG35-8AA0	6SL3330-7TG35-8AA3 6SL3335-7TG35-8AA3	3RT1476-6AP36
800	735	6SL3300-7TG37-4AA0 6SL3305-7TG37-4AA3	6SL3330-7TG37-4AA3 6SL3335-7TG37-4AA3	3RT1476-6AP36 (3 units)
900	810	6SL3300-7TG41-3AA0	6SL3335-7TG38-1AA3	3WL1110-2BB34-4AN2-Z C22¹⁾
1100	1025	6SL3300-7TG41-3AA0 6SL3305-7TG41-0AA3	6SL3330-7TG41-0AA3 6SL3335-7TG41-0AA3	3WL1112-2BB34-4AN2-Z C22¹⁾
1400	1270	6SL3300-7TG41-3AA0 6SL3305-7TG41-3AA3	6SL3330-7TG41-3AA3 6SL3335-7TG41-3AA3	3WL1116-2BB34-4AN2-Z C22¹⁾
1700	1560	6SL3305-7TG41-6AA3	6SL3335-7TG41-6AA3	3WL1116-2BB34-4AN2-Z C22¹⁾

¹⁾ The breakers must always be switched ON and OFF by the sequence control. An interlocking set 3WL9111-0BA21-0AA0 as described in Catalog LV 10 should be provided for the circuit breakers in order to exclude the risk of unintentional manual operation. Manual operation bypasses the pre-charging circuit and can therefore destroy the Line Module.

SINAMICS S120 Chassis Format Converter Units

System components

Line-side power components > Recommended line-side system components

Overview (continued)

Rated power at 400 V or 690 V	Rated input current	Suitable for Active Interface Module	Suitable for Active Line Module	Switch disconnecter without handle and shaft	Switch disconnecter with handle and shaft	Cable protection fuse		Cable protection fuse incl. semiconductor protection	
						Rated current	Article No.	Rated current	Article No.
kW	A	6SL3300-... 6SL3305-...	6SL3330-... 6SL3335-...	Article No.	Article No.	A	Article No.	A	Article No.
Line voltage 380 ... 480 V 3 AC									
132	210	7TE32-6AA0	7TE32-1AA3	3KL5530-1AB01	3KL5530-1GB01	315	3NA3252	315	3NE1230-2
160	260	7TE32-6AA0	7TE32-6AA3	3KL5730-1AB01	3KL5730-1GB01	355	3NA3254	350	3NE1331-2
235	380	7TE33-8AA0	7TE33-8AA3	3KL5730-1AB01	3KL5730-1GB01	500	3NA3365	500	3NE1334-2
300	490	7TE35-0AA0	7TE35-0AA3 7TE35-0AA3 ¹⁾	3KL6130-1AB02	3KL6130-1GB02	630	3NA3372	630	3NE1436-2
380	605	7TE38-4AA0	7TE36-1AA3 7TE36-1AA3 ¹⁾	3KL6230-1AB02	3KL6230-1GB02	800	3NA3475	800	3NE1438-2
500	840	7TE38-4AA0	7TE38-4AA3 7TE38-4AA3 ¹⁾	–	–	2 × 425	3NA3362 (2 units)	2 × 500	3NE1334-2 (2 units)
630	985	7TE41-4AA0	7TE41-0AA3 7TE41-0AA3 ¹⁾	–	–	2 × 500	3NA3365 (2 units)	2 × 630	3NE1436-2 (2 units)
800	1260	7TE41-4AA0	7TE41-2AA3	–	–	3 × 425	3NA3362 (2 units)	2 × 850	3NE1448-2 (2 units)
900	1405	7TE41-4AA0 7TE41-4AA3 ¹⁾	7TE41-4AA3 7TE41-4AA3 ¹⁾	–	–	3 × 500	3NA3365 (2 units)	2 × 850	3NE1448-2 (2 units)
Line voltage 500 ... 690 V 3 AC									
560/630	575	7TG35-8AA0	7TG35-8AA3 7TG35-8AA3 ¹⁾	3KL6130-1AB02	3KL6130-1GB02	2 × 315	3NA3352-6 (2 units)	670	3NE1447-2
800	735	7TG37-4AA0 7TG37-4AA3 ¹⁾	7TG37-4AA3 7TG37-4AA3 ¹⁾	3KL6230-1AB02	3KL6230-1GB02	2 × 400	3NA3360-6 (2 units)	850	3NE1448-2
900	810	7TG41-3AA0	7TG38-1AA3 ¹⁾	–	–	2 × 500	3NA3365-6 (2 units)	2 × 560	3NE1435-2 (2 units)
1100	1025	7TG41-3AA0 7TG41-0AA3 ¹⁾	7TG41-0AA3 7TG41-0AA3 ¹⁾	–	–	3 × 355	3NA3354-6 (3 units)	2 × 630	3NE1436-2 (2 units)
1400	1270	7TG41-3AA0 7TG41-3AA3 ¹⁾	7TG41-3AA3 7TG41-3AA3 ¹⁾	–	–	3 × 500	3NA3365-6 (3 units)	2 × 800	3NE1438-2 (2 units)
1700	1560	7TG41-6AA3 ¹⁾	7TG41-6AA3 ¹⁾	–	–	4 × 850	3NA3365-6 (4 units)	3 × 630	3NE1436-2 (3 units)

¹⁾ Liquid-cooled version, 6SL3305-... or 6SL3335-...

SINAMICS S120 Chassis Format Converter Units

System components

DC link components > Braking Modules

Overview

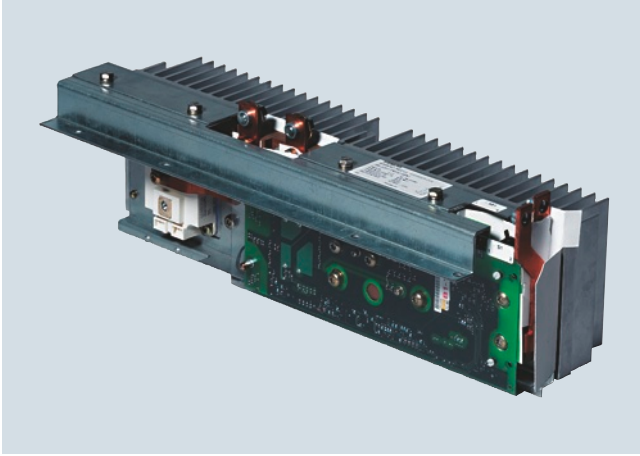

A Braking Module and the matching external braking resistor are required to bring drives to a controlled standstill in the event of a power failure (e.g. with an EMERGENCY STOP) or to limit the DC link voltage for brief periods of regenerative operation, e.g. if the Line Module is not capable of energy recovery.

The Braking Module includes the power electronics and the associated control circuit. During operation, the DC link energy is converted to heat loss in an external braking resistor.

The Braking Module works independently of the converter control.

Several Braking Modules can be operated in parallel, but a separate braking resistor must be connected to each Braking Module.

Braking Modules are designed to be integrated into air-cooled Motor Modules, Line Modules or Power Modules and are cooled by the fans on these modules. The supply voltage for the electronics is taken from the DC link. The Braking Modules are connected to the DC link by means of the busbar sets included in the scope of supply or flexible cables and, in the case of Basic Line Modules of frame size GB or GD, using a separate cable harness set.

The activation threshold of the Braking Module can be adjusted by means of a DIP switch. The braking power values specified in the technical specifications apply to the upper activation threshold.

Design

The Braking Modules have the following interfaces as standard:

- 1 DC link connection
- 1 braking resistor connection
- 1 digital input (block Braking Module / acknowledge error)
- 1 digital output (Braking Module inhibited)
- 1 DIP switch for adjusting the activation threshold

Information about Braking Module activation thresholds and other notes are included in the [SINAMICS Low Voltage Engineering Manual](#).

Selection and ordering data

Rated power P_{DB} kW	Peak power P_{15} kW	Frame size	Braking Module Article No.
Line voltage 380 ... 480 V 3 AC DC link voltage 510 ... 720 V DC			
25	125	FX/FB	6SL3300-1AE31-3AA0
50	250	GX/GB/GD	6SL3300-1AE32-5AA0
50	250	HX/JX	6SL3300-1AE32-5BA0
Line voltage 500 ... 600 V 3 AC DC link voltage 675 ... 900 V DC			
25	125	FX/FB	6SL3300-1AF31-3AA0
50	250	GX/GB/GD	6SL3300-1AF32-5AA0
50	250	HX/JX	6SL3300-1AF32-5BA0
Line voltage 660 ... 690 V 3 AC DC link voltage 890 ... 1035 V DC			
25	125	FX/FB	6SL3300-1AH31-3AA0
50	250	GX/GB/GD	6SL3300-1AH32-5AA0
50	250	HX/JX	6SL3300-1AH32-5BA0
Description			Article No.
Accessories			
Cable harness set for mounting a Braking Module of frame size GX into a Basic Line Module of frame size GB or GD			6SL3366-2NG00-0AA0

3

SINAMICS S120 Chassis Format Converter Units

System components

DC link components > Braking Modules

Integration

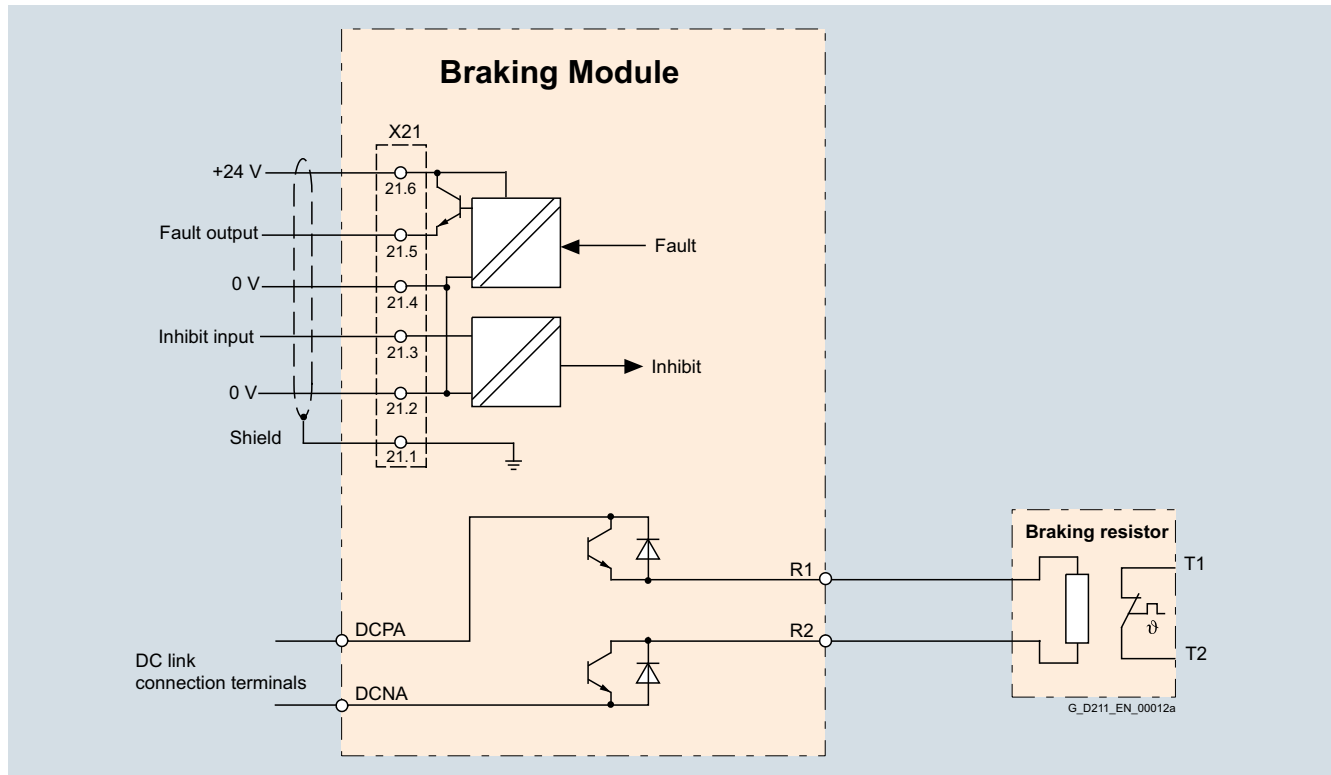

Connection example of a Braking Module

Characteristic curves

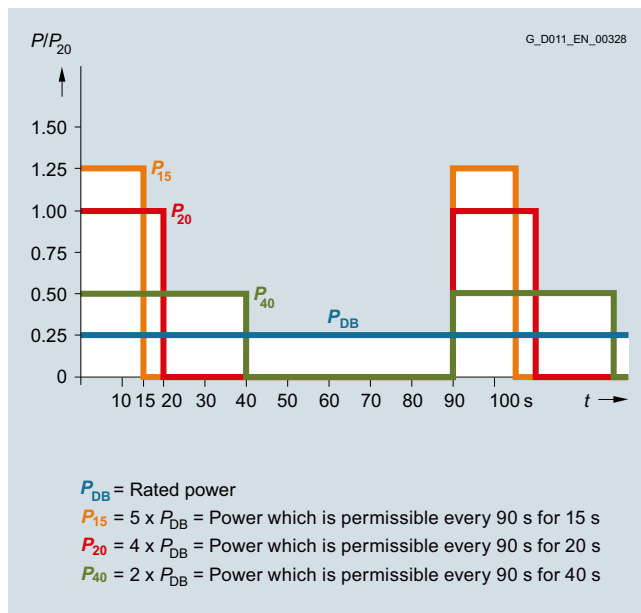

Load diagram for Braking Modules and braking resistor

SINAMICS S120 Chassis Format Converter Units

System components

DC link components > Braking Modules

Technical specifications

Line voltage 380 ... 480 V 3 AC DC link voltage 510 ... 720 V DC		Braking Module		
		6SL3300-1AE31-3AA0	6SL3300-1AE32-5AA0	6SL3300-1AE32-5BA0
Power				
• Rated power P_{DB}	kW	25	50	50
• Peak power P_{15}	kW	125	250	250
• Power P_{20}	kW	100	200	200
• Power P_{40}	kW	50	100	100
Activation thresholds (adjustable via DIP switch)		V	774 (factory setting) or 673	774 (factory setting) or 673
Digital inputs in accordance with IEC 61131-2 Type 1				
• Voltage	V	24 DC	24 DC	24 DC
• Low level (an open digital input is interpreted as "low")	V	-3 ... +5	-3 ... +5	-3 ... +5
• High level	V	15 ... 30	15 ... 30	15 ... 30
• Current consumption at 24 V DC, typ.	mA	10	10	10
• Conductor cross-section, max.	mm ²	1.5	1.5	1.5
Digital outputs (continuously short-circuit proof)				
• Voltage	V	24 DC	24 DC	24 DC
• Load current per digital output, max.	mA	500	500	500
• Conductor cross-section, max.	mm ²	1.5	1.5	1.5
R1/R2 connection				
• Conductor cross-section, max.	mm ²	M8 nut 35	M8 nut 50	M8 nut 50
Weight, approx.		kg	3.6	7.3
Suitable for installation in air-cooled Power Modules, Line Modules or Motor Modules				
• Air-cooled	Frame size	FX/FB	GX/GB/GD ¹⁾	HX/JX

Line voltage 500 ... 600 V 3 AC DC link voltage 675 ... 900 V DC		Braking Module		
		6SL3300-1AF31-3AA0	6SL3300-1AF32-5AA0	6SL3300-1AF32-5BA0
Power				
• Rated power P_{DB}	kW	25	50	50
• Peak power P_{15}	kW	125	250	250
• Power P_{20}	kW	100	200	200
• Power P_{40}	kW	50	100	100
Activation thresholds (adjustable via DIP switch)		V	967 (factory setting) or 841	967 (factory setting) or 841
Digital inputs in accordance with IEC 61131-2 Type 1				
• Voltage	V	24 DC	24 DC	24 DC
• Low level (an open digital input is interpreted as "low")	V	-3 ... +5	-3 ... +5	-3 ... +5
• High level	V	15 ... 30	15 ... 30	15 ... 30
• Current consumption at 24 V DC, typ.	mA	10	10	10
• Conductor cross-section, max.	mm ²	1.5	1.5	1.5
Digital outputs (continuously short-circuit proof)				
• Voltage	V	24 DC	24 DC	24 DC
• Load current per digital output, max.	mA	500	500	500
• Conductor cross-section, max.	mm ²	1.5	1.5	1.5
R1/R2 connection				
• Conductor cross-section, max.	mm ²	M8 nut 35	M8 nut 50	M8 nut 50
Weight, approx.		kg	3.6	7.5
Suitable for installation in air-cooled Power Modules, Line Modules or Motor Modules				
• Air-cooled	Frame size	FX/FB	GX/GB/GD ¹⁾	HX/JX

¹⁾ Cable harness set 6SL3366-2NG00-0AA0 is required to connect the Braking Module to a Basic Line Module of frame size GB or GD.

SINAMICS S120 Chassis Format Converter Units

System components

DC link components > Braking Modules

Technical specifications (continued)

Line voltage 660 ... 690 V 3 AC DC link voltage 890 ... 1035 V DC		Braking Module		
		6SL3300-1AH31-3AA0	6SL3300-1AH32-5AA0	6SL3300-1AH32-5BA0
Power				
• Rated power P_{DB}	kW	25	50	50
• Peak power P_{15}	kW	125	250	250
• Power P_{20}	kW	100	200	200
• Power P_{40}	kW	50	100	100
Activation thresholds (adjustable via DIP switch)		V	1153 (factory setting) or 1070	1153 (factory setting) or 1070
Digital inputs in accordance with IEC 61131-2 Type 1				
• Voltage	V	24 DC	24 DC	24 DC
• Low level (an open digital input is interpreted as "low")	V	-3 ... +5	-3 ... +5	-3 ... +5
• High level	V	15 ... 30	15 ... 30	15 ... 30
• Current consumption at 24 V DC, typ.	mA	10	10	10
• Conductor cross-section, max.	mm ²	1.5	1.5	1.5
Digital outputs (continuously short-circuit proof)				
• Voltage	V	24 DC	24 DC	24 DC
• Load current per digital output, max.	mA	500	500	500
• Conductor cross-section, max.	mm ²	1.5	1.5	1.5
R1/R2 connection				
• Conductor cross-section, max.	mm ²	M8 nut 35	M8 nut 50	M8 nut 50
Weight, approx.		kg	3.6	7.3
Suitable for installation in air-cooled Power Modules, Line Modules or Motor Modules				
• Air-cooled	Frame size	FX/FB	GX/GB/GD ¹⁾	HX/JX

¹⁾ Cable harness set 6SL3366-2NG00-0AA0 is required to connect the Braking Module to a Basic Line Module of frame size GB or GD.

SINAMICS S120 Chassis Format Converter Units

System components

DC link components > Braking resistors

Overview

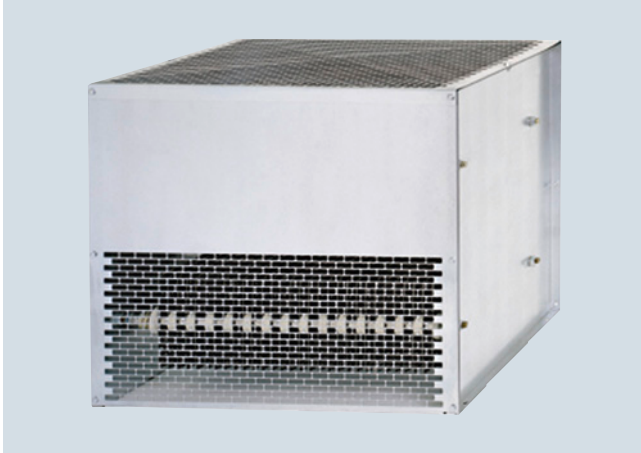

Excess energy in the DC link is dissipated via the braking resistor.

The braking resistor is connected to a Braking Module.

By positioning the braking resistor outside the cabinet or switch-gear room, it is possible to extract the heat losses away from the Line Modules / Motor Modules. This reduces the level of air conditioning required.

The maximum permissible cable length between the Braking Module and braking resistor is 100 m.

Two braking resistors with different rated and peak power values are available for the devices.

The braking resistor is monitored on the basis of the duty cycle. A temperature switch (NC contact) is also fitted. This responds when the maximum permissible temperature is exceeded and can be evaluated by a controller.

Information about possible load cycles of the braking resistors and other notes are included in the SINAMICS Low Voltage Engineering Manual.

Selection and ordering data

Rated power P_{DB} kW	Suitable for Braking Module 6SL3300-...	Braking resistor Article No.
Line voltage 380 ... 480 V 3 AC DC link voltage 510 ... 720 V DC		
25	1AE31-3AA0	6SL3000-1BE31-3AA0
50	1AE32-5 . A0	6SL3000-1BE32-5AA0
Line voltage 500 ... 600 V 3 AC DC link voltage 675 ... 900 V DC		
25	1AF31-3AA0	6SL3000-1BF31-3AA0
50	1AF32-5 . A0	6SL3000-1BF32-5AA0
Line voltage 660 ... 690 V 3 AC DC link voltage 890 ... 1035 V DC		
25	1AH31-3AA0	6SL3000-1BH31-3AA0
50	1AH32-5 . A0	6SL3000-1BH32-5AA0

Characteristic curves

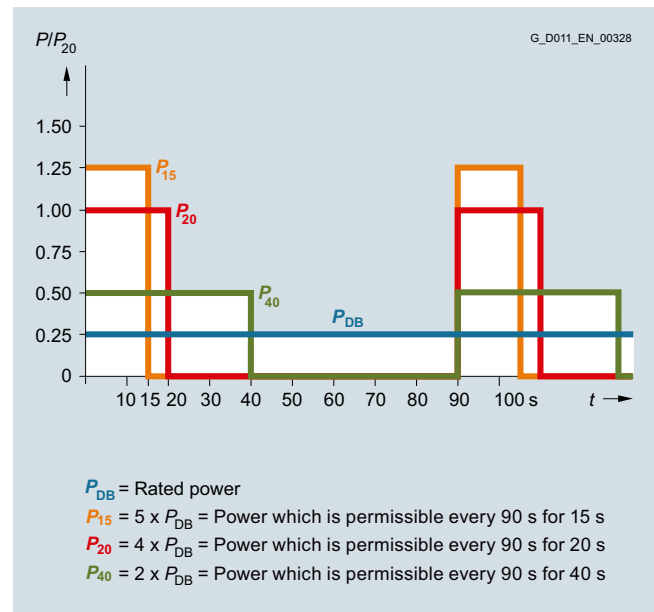

Load diagram for Braking Modules and braking resistors

SINAMICS S120 Chassis Format Converter Units

System components

DC link components > Braking resistors

Technical specifications

Line voltage 380 ... 480 V 3 AC DC link voltage 510 ... 720 V DC		Braking resistor	
		6SL3000-1BE31-3AA0	6SL3000-1BE32-5AA0
Resistance	Ω	4.4 (±7.5 %)	2.2 (±7.5 %)
Rated power P_{DB} (continuous braking power)	kW	25	50
Power P_{15}	kW	125	250
Power P_{20}	kW	100	200
Power P_{40}	kW	50	100
Current, max.	A	189	378
Power connection		M10 stud	M10 stud
• Conductor cross section, max. (IEC)	mm ²	50	70
Degree of protection		IP20	IP20
Dimensions			
• Width	mm	740	810
• Height	mm	600	1325
• Depth	mm	486	486
Weight, approx.	kg	50	120
Suitable for Braking Module	Type	6SL3300-1AE31-3AA0	6SL3300-1AE32-5 . A0
Line voltage 500 ... 600 V 3 AC DC link voltage 675 ... 900 V DC		Braking resistor	
		6SL3000-1BF31-3AA0	6SL3000-1BF32-5AA0
Resistance	Ω	6.8 (±7.5 %)	3.4 (±7.5 %)
Rated power P_{DB} (continuous braking power)	kW	25	50
Power P_{15}	kW	125	250
Power P_{20}	kW	100	200
Power P_{40}	kW	50	100
Current, max.	A	189	378
Power connection		M10 stud	M10 stud
• Conductor cross section, max. (IEC)	mm ²	50	70
Degree of protection		IP20	IP20
Dimensions			
• Width	mm	740	810
• Height	mm	600	1325
• Depth	mm	486	486
Weight, approx.	kg	50	120
Suitable for Braking Module	Type	6SL3300-1AF31-3AA0	6SL3300-1AF32-5 . A0
Line voltage 660 ... 690 V 3 AC DC link voltage 890 ... 1035 V DC		Braking resistor	
		6SL3000-1BH31-3AA0	6SL3000-1BH32-5AA0
Resistance	Ω	9.8 (±7.5 %)	4.9 (±7.5 %)
Rated power P_{DB} (continuous braking power)	kW	25	50
Power P_{15}	kW	125	250
Power P_{20}	kW	100	200
Power P_{40}	kW	50	100
Current, max.	A	125	255
Power connection		M10 stud	M10 stud
• Conductor cross section, max. (IEC)	mm ²	50	70
Degree of protection		IP20	IP20
Dimensions			
• Width	mm	740	810
• Height	mm	600	1325
• Depth	mm	486	486
Weight, approx.	kg	50	120
Suitable for Braking Module	Type	6SL3300-1AH31-3AA0	6SL3300-1AH32-5 . A0

SINAMICS S120 Chassis Format Converter Units

System components

DC link components > DC link fuses

Overview

Suitable DC link fuses are assigned depending on the power rating of the Motor Modules. Further information about the fuses listed is provided in the Catalogs IC 10 and LV 10.

Assignment of the DC link fuses to the Motor Modules chassis format, liquid-cooled

Type rating at 400 V	Rated DC link current for power supplied via Basic Line Module / Active Line Module	Suitable for Motor Module chassis format	DC link fuse according to IEC				DC link fuse according to UL ¹⁾			
			Rated current	Quantity/Phase	Frame size	Article No.	Rated current	Quantity/Phase	Frame size	Article No.
kW	A	6SL3325-...	A			Article No.	A			Article No.
Line voltage 380 V ... 480 V 3 AC										
110	256/230	1TE32-1AA3	315	1	1	3NE3230-0B	315	1	1	3NE3230-0B
							315	1	2L	3NB1231-4KK11
132	317/287	1TE32-6AA3	400	1	1	3NE3232-0B	400	1	1	3NE3232-0B
							400	1	2L	3NB1234-4KK11
160	380/340	1TE33-1AA3	450	1	1	3NE3233	450	1	1	3NE3233
							500	1	3L	3NB1337-4KK11
250	600/538	1TE35-0AA3	630	1	2	3NE3236	630	1	2	3NE3236
							800	1	3L	3NB1345-4KK11
315	738/664	1TE36-1AA3	800	1	2	3NE3338-8	800	1	2	3NE3338-8
							800	1	3L	3NB2345-4KK16
400	894/805	1TE37-5AA3	500	2	2	3NE3334-0B	1000	1	3L	3NB2350-4KK16
450	1025/922	1TE38-4AA3	560	2	2	3NE3335	560	2	2	3NE3335
							1000	1	3L	3NB2350-4KK16
560	1202/1080	1TE41-0AA3	630	2	2	3NE3336	630	2	2	3NE3336
							1400	1	3L	3NB2355-4KK16
710	1512/1361	1TE41-2AA3	900	2	2	3NE3340-8	2100	1	3L	3NB2364-4KK17
800	1714/1544	1TE41-4AA3	900	2	2	3NE3340-8	900	2	2	3NE3340-8
							2100	1	3L	3NB2364-4KK17
800	1550/1403	1TE41-4AS3 ²⁾	900	2	2	3NE3340-8	2100	1	3L	3NB2364-4KK17

¹⁾ To achieve a UL-approved system, it is absolutely essential to use the fuse types specified in the table.

²⁾ This Motor Module has been specifically designed for loads demanding a high dynamic performance.

SINAMICS S120 Chassis Format Converter Units

System components

DC link components > DC link fuses

Overview (continued)

Type rating at 690 V	Rated DC link current for power supplied via Basic Line Module / Active Line Module	Suitable for Motor Module chassis format 6SL3325-...	DC link fuse according to IEC				DC link fuse according to UL ¹⁾			
			Rated current	Quantity/Phase	Frame size	Article No.	Rated current	Quantity/Phase	Frame size	Article No.
kW	A		A				A			
Line voltage 500 ... 690 V 3 AC										
90	122/110	1TG31-0AA3	160	1	1	3NE3224	160	1	1	3NE3224
							200	1	1L	3NB1126-4KK11
132	183/165	1TG31-5AA3	200	1	1	3NE3225	200	1	1	3NE3225
							250	1	1L	3NB1128-4KK11
200	263/237	1TG32-2AA3	315	1	1	3NE3230-0B	315	1	1	3NE3230-0B
							315	1	2L	3NB1231-4KK11
315	403/363	1TG33-3AA3	450	1	2	3NE3233	450	1	2	3NE3233
							500	1	3L	3NB1337-4KK11
450	558/502	1TG34-7AA3	630	1	2	3NE3336	800	1	3L	3NB1345-4KK11
560	702/632	1TG35-8AA3	400	2	1	3NE3232-0B	400	2	1	3NE3232-0B
							800	1	3L	3NB2345-4KK16
710	903/759	1TG37-4AA3	560	2	2	3NE3335	1000	1	3L	3NB2350-4KK16
800	990/891	1TG38-0AA3 ²⁾	560	2	2	3NE3335	1000	1	3L	3NB2350-4KK16
800	990/891	1TG38-1AA3	560	2	2	3NE3335	560	2	2	3NE3335
							1000	1	3L	3NB2350-4KK16
1000	1250/1125	1TG41-0AA3	710	2	2	3NE3337-8	710	2	2	3NE3337-8
							1600	1	3L	3NB2357-4KK16
1200	1550/1395	1TG41-3AA3	900	2	2	3NE3340-8	900	2	2	3NE3340-8
							2100	1	3L	3NB2364-4KK17
1500	1903/1605	1TG41-6AA3	710	3	2	3NE3337-8	2400	1	3L	3NB2366-4KK17

¹⁾ To achieve a UL-approved system, it is absolutely essential to use the fuse types specified in the table.

²⁾ Device 6SL3325-1TG38-0AA3 is optimized for a base pulse frequency of 1.25 kHz, for an increased pulse frequency, the derating factor is higher than for the device 6SL3325-1TG38-1AA3.

SINAMICS S120 Chassis Format Converter Units

System components

Motor-side power components > Motor reactors

Overview

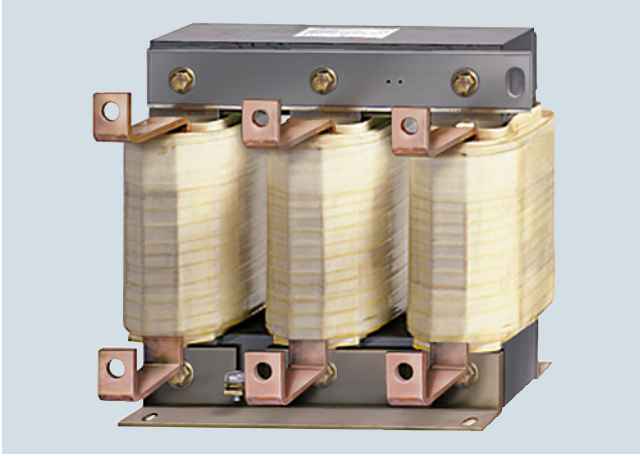

Motor reactors reduce the voltage load on the motor windings by reducing the voltage gradients at the motor terminals that occur during converter operation. At the same time, the capacitive charge/discharge currents that place an additional load on the converter output when long motor cables are used, are reduced. For group drives, output reactors should always be used. The maximum permissible output frequency when a motor reactor is used is 150 Hz.

The motor reactor must be installed as close as possible to the Motor Module or Power Module. Up to two motor reactors can be connected in series.

Motor reactors are approved for use only in conjunction with Vector and V/f control modes.

For additional notes on the use of motor reactors, please refer to the [SINAMICS Low Voltage Configuration Manual](#).

3

Selection and ordering data

Suitable for Power Module		Suitable for Motor Module		Type rating at 400 V/ 690 V kW	Rated output current A	Motor reactor Article No.
Air-cooled	Liquid-cooled	Air-cooled	Liquid-cooled			
Line voltage 380 ... 480 V 3 AC						
6SL3310-1TE32-1AA3	6SL3315-1TE32-1AA3	6SL3320-1TE32-1AA3	6SL3325-1TE32-1AA3	110	210	6SL3000-2BE32-1AA0
6SL3310-1TE32-6AA3	6SL3315-1TE32-6AA3	6SL3320-1TE32-6AA3	6SL3325-1TE32-6AA3	132	260	6SL3000-2BE32-6AA0
6SL3310-1TE33-1AA3	6SL3315-1TE33-1AA3	6SL3320-1TE33-1AA3	6SL3325-1TE33-1AA3	160	310	6SL3000-2BE33-2AA0
6SL3310-1TE33-8AA3	–	6SL3320-1TE33-8AA3	–	200	380	6SL3000-2BE33-8AA0
6SL3310-1TE35-0AA3	6SL3315-1TE35-0AA3	6SL3320-1TE35-0AA3	6SL3325-1TE35-0AA3	250	490	6SL3000-2BE35-0AA0
–	–	6SL3320-1TE36-1AA3	6SL3325-1TE36-1AA3	315	605	6SL3000-2AE36-1AA0
–	–	6SL3320-1TE37-5AA3	6SL3325-1TE37-5AA3	400	745	6SL3000-2AE38-4AA0
–	–	6SL3320-1TE38-4AA3	6SL3325-1TE38-4AA3	450	840	
–	–	6SL3320-1TE41-0AA3	6SL3325-1TE41-0AA3	560	985	6SL3000-2AE41-0AA0
–	–	6SL3320-1TE41-2AA3	6SL3325-1TE41-2AA3	710	1260	6SL3000-2AE41-4AA0
–	–	6SL3320-1TE41-4AA3	6SL3325-1TE41-4AA3	800	1405	
			6SL3325-1TE41-4AS3 ¹⁾	800	1330	
Line voltage 500 ... 690 V 3 AC						
–	–	6SL3320-1TG28-5AA3	–	75	85	6SL3000-2AH31-0AA0
–	–	6SL3320-1TG31-0AA3	6SL3325-1TG31-0AA3	90	100	
–	–	6SL3320-1TG31-2AA3	–	110	120	6SL3000-2AH31-5AA0
–	–	6SL3320-1TG31-5AA3	6SL3325-1TG31-5AA3	132	150	
–	–	6SL3320-1TG31-8AA3	–	160	175	6SL3000-2AH31-8AA0
–	–	6SL3320-1TG32-2AA3	6SL3325-1TG32-2AA3	200	215	6SL3000-2AH32-4AA0
–	–	6SL3320-1TG32-6AA3	–	250	260	6SL3000-2AH32-6AA0
–	–	6SL3320-1TG33-3AA3	6SL3325-1TG33-3AA3	315	330	6SL3000-2AH33-6AA0
–	–	6SL3320-1TG34-1AA3	–	400	410	6SL3000-2AH34-5AA0
–	–	6SL3320-1TG34-7AA3	6SL3325-1TG34-7AA3	450	465	6SL3000-2AH34-7AA0
–	–	6SL3320-1TG35-8AA3	6SL3325-1TG35-8AA3	560	575	6SL3000-2AH35-8AA0
–	–	6SL3320-1TG37-4AA3	6SL3325-1TG37-4AA3	710	735	6SL3000-2AH38-1AA0
–	–	6SL3320-1TG38-1AA3	6SL3325-1TG38-0AA3	800	810	
			6SL3325-1TG38-1AA3			
–	–	6SL3320-1TG38-8AA3	–	900	910	6SL3000-2AH41-0AA0
–	–	6SL3320-1TG41-0AA3	6SL3325-1TG41-0AA3	1000	1025	6SL3000-2AH41-1AA0
–	–	6SL3320-1TG41-3AA3	6SL3325-1TG41-3AA3	1200	1270	6SL3000-2AH41-3AA0

¹⁾ This Motor Module has been specifically designed for loads demanding a high dynamic performance.

SINAMICS S120 Chassis Format Converter Units

System components

Motor-side power components > Motor reactors

Technical specifications

Line voltage 380 ... 480 V 3 AC		Motor reactor (for pulse frequencies of 2 kHz to 4 kHz)									
		6SL3000-2BE32-1AA0		6SL3000-2BE32-6AA0		6SL3000-2BE33-2AA0		6SL3000-2BE33-8AA0		6SL3000-2BE35-0AA0	
Rated current	A	210		260		310		380		490	
Power loss, max. ¹⁾	kW	0.486		0.5		0.47		0.5		0.5	
Load connection		1 × hole for M10		1 × hole for M10		1 × hole for M10		1 × hole for M10		1 × hole for M12	
PE connection		M8 screw		M8 screw		M8 screw		M8 screw		M8 screw	
Cable length, max. between the motor reactor and motor (number of reactors in series)											
• Shielded	m	(1)	(2)	(1)	(2)	(1)	(2)	(1)	(2)	(1)	(2)
• Unshielded	m	300	525	300	525	300	525	300	525	300	525
	m	450	787	450	787	450	787	450	787	450	787
Degree of protection		IP00		IP00		IP00		IP00		IP00	
Dimensions											
• Width	mm	300		300		300		300		300	
• Height	mm	285		315		285		285		365	
• Depth	mm	257		277		257		277		277	
Weight, approx.	kg	66		66		66		73		100	
Suitable for Power Module		6SL3310-1TE32-1AA3 6SL3315-1TE32-1AA3		6SL3310-1TE32-6AA3 6SL3315-1TE32-6AA3		6SL3310-1TE33-1AA3 6SL3315-1TE33-1AA3		6SL3310-1TE33-8AA3		6SL3310-1TE35-0AA3 6SL3315-1TE35-0AA3	
Suitable for Motor Module		6SL3320-1TE32-1AA3 6SL3325-1TE32-1AA3		6SL3320-1TE32-6AA3 6SL3325-1TE32-6AA3		6SL3320-1TE33-1AA3 6SL3325-1TE33-1AA3		6SL3320-1TE33-8AA3		6SL3320-1TE35-0AA3 6SL3325-1TE35-0AA3	
• Rated current of Motor Module or Power Module	A	210		260		310		380		490	
• Type rating of Motor Module or Power Module	kW	110		132		160		200		250	

Line voltage 380 ... 480 V 3 AC		Motor reactor (for pulse frequencies of 1.25 kHz to 2.5 kHz)											
		6SL3000-2AE36-1AA0		6SL3000-2AE38-4AA0				6SL3000-2AE41-0AA0		6SL3000-2AE41-4AA0			
Rated current	A	605		745		840		985		1260		1405	
Power loss, max. ¹⁾	kW	0.9		0.84		0.943		1.062		0.9		1.054	
Load connection		1 × hole for M12		1 × hole for M12		1 × hole for M12		1 × hole for M12		2 × hole for M12		2 × hole for M12	
PE connection		M10 screw		M10 screw		M10 screw		M10 screw		M10 screw		M10 screw	
Cable length, max. between the motor reactor and motor (number of reactors in series)													
• Shielded	m	(1)	(2)	(1)	(2)	(1)	(2)	(1)	(2)	(1)	(2)	(1)	(2)
• Unshielded	m	300	525	300	525	300	525	300	525	300	525	300	525
	m	450	787	450	787	450	787	450	787	450	787	450	787
Degree of protection		IP00		IP00		IP00		IP00		IP00		IP00	
Dimensions													
• Width	mm	410		410		410		410		460		460	
• Height	mm	392		392		392		392		392		392	
• Depth	mm	292		292		292		302		326		326	
Weight, approx.	kg	130		140		140		146		179		179	
Suitable for Motor Module		6SL3320-1TE36-1AA3 6SL3325-1TE36-1AA3		6SL3320-1TE37-5AA3 6SL3325-1TE37-5AA3		6SL3320-1TE38-4AA3 6SL3325-1TE38-4AA3		6SL3320-1TE41-0AA3 6SL3325-1TE41-0AA3		6SL3320-1TE41-2AA3 6SL3325-1TE41-2AA3		6SL3320-1TE41-4AA3 6SL3325-1TE41-4AA3 6SL3325-1TE41-4AS3 ²⁾	
• Rated current of the Motor Module	A	605		745		840		985		1260		1405	
• Type rating of the Motor Module	kW	315		400		450		560		710		800	

¹⁾ The specified power loss represents the maximum value at 100% utilization. The value is lower under normal operating conditions.

²⁾ This Motor Module has been specifically designed for loads demanding a high dynamic performance.

SINAMICS S120 Chassis Format Converter Units

System components

Motor-side power components > Motor reactors

Technical specifications (continued)

Line voltage 500 ... 690 V 3 AC		Motor reactor (for pulse frequencies of 1.25 kHz to 2.5 kHz)											
		6SL3000-2AH31-0AA0				6SL3000-2AH31-5AA0				6SL3000-2AH31-8AA0		6SL3000-2AH32-4AA0	
Rated current	A	85		100		120		150		175		215	
Power loss, max. ¹⁾	kW	0.257		0.3		0.318		0.335		0.4		0.425	
Load connection		Flat connector for M10 screw		Flat connector for M10 screw		Flat connector for M10 screw		Flat connector for M10 screw		Flat connector for M10 screw		Flat connector for M10 screw	
PE connection		M6 screw		M6 screw		M6 screw		M6 screw		M6 screw		M6 screw	
Cable length, max. between the motor reactor and motor (number of reactors in series)		(1)	(2)	(1)	(2)	(1)	(2)	(1)	(2)	(1)	(2)	(1)	(2)
• Shielded	m	300	525	300	525	300	525	300	525	300	525	300	525
• Unshielded	m	450	787	450	787	450	787	450	787	450	787	450	787
Degree of protection		IP00		IP00		IP00		IP00		IP00		IP00	
Dimensions													
• Width	mm	270		270		270		270		300		300	
• Height	mm	248		248		248		248		285		285	
• Depth	mm	200		200		200		200		212		212	
Weight, approx.	kg	25		25		25.8		25.8		34		34	
Suitable for Motor Module		6SL3320-1TG28-5AA3		6SL3320-1TG31-0AA3		6SL3320-1TG31-2AA3		6SL3320-1TG31-5AA3		6SL3320-1TG31-8AA3		6SL3320-1TG32-2AA3	
• Rated current of the Motor Module	A	85		100		120		150		175		215	
• Type rating of the Motor Module	kW	75		90		110		132		160		200	

Line voltage 500 ... 690 V 3 AC		Motor reactor (for pulse frequencies of 1.25 kHz to 2.5 kHz)											
		6SL3000-2AH32-6AA0		6SL3000-2AH33-6AA0		6SL3000-2AH34-5AA0		6SL3000-2AH34-7AA0		6SL3000-2AH35-8AA0		6SL3000-2AH38-1AA0	
Rated current	A	260		330		410		465		575		735	
Power loss, max. ¹⁾	kW	0.44		0.45		0.545		0.72		0.8		0.96	
Load connection		Flat connector for M10 screw		Flat connector for M10 screw		Flat connector for M12 screw		Flat connector for M12 screw		Flat connector for M12 screw		Flat connector for M12 screw	
PE connection		M6 screw		M6 screw		M8 screw		M8 screw		M8 screw		M8 screw	
Cable length, max. between the motor reactor and motor (number of reactors in series)		(1)	(2)	(1)	(2)	(1)	(2)	(1)	(2)	(1)	(2)	(1)	(2)
• Shielded	m	300	525	300	525	300	525	300	525	300	525	300	525
• Unshielded	m	450	787	450	787	450	787	450	787	450	787	450	787
Degree of protection		IP00		IP00		IP00		IP00		IP00		IP00	
Dimensions													
• Width	mm	300		300		350		410		410		410	
• Height	mm	285		285		330		392		392		392	
• Depth	mm	212		212		215		292		292		279	
Weight, approx.	kg	40		46		68		80		80		146	
Suitable for Motor Module		6SL3320-1TG32-6AA3		6SL3320-1TG33-3AA3		6SL3320-1TG34-1AA3		6SL3320-1TG34-7AA3		6SL3320-1TG35-8AA3		6SL3320-1TG37-4AA3	
• Rated current of the Motor Module	A	260		330		410		465		575		735	
• Type rating of the Motor Module	kW	250		315		400		450		560		710	

¹⁾ The specified power loss represents the maximum value at 100% utilization. The value is lower under normal operating conditions.

SINAMICS S120 Chassis Format Converter Units

System components

Motor-side power components > Motor reactors

Technical specifications (continued)

Line voltage 500 ... 690 V 3 AC		Motor reactor (for pulse frequencies of 1.25 kHz to 2.5 kHz)							
		6SL3000-2AH38-1AA0		6SL3000-2AH41-0AA0		6SL3000-2AH41-1AA0		6SL3000-2AH41-3AA0	
Rated current	A	810		910		1025		1270	
Power loss, max. ¹⁾	kW	1.0		0.97		1.05		0.95	
Load connection		Flat connector for M12 screw		Flat connector for M12 screw		Flat connector for M12 screw		Flat connector for M12 screw	
PE connection		M8 screw		M8 screw		M8 screw		M8 screw	
Cable length, max. between the motor reactor and motor (number of reactors in series)		(1)	(2)	(1)	(2)	(1)	(2)	(1)	(2)
• Shielded	m	300	525	300	525	300	525	300	525
• Unshielded	m	450	787	450	787	450	787	450	787
Degree of protection		IP00		IP00		IP00		IP00	
Dimensions									
• Width	mm	410		410		410		460	
• Height	mm	392		392		392		392	
• Depth	mm	279		279		317		296	
Weight, approx.	kg	146		150		163		153	
Suitable for Motor Module		6SL3320-1TG38-1AA3 6SL3325-1TG38-0AA3 6SL3325-1TG38-1AA3		6SL3320-1TG38-8AA3		6SL3320-1TG41-0AA3 6SL3325-1TG41-0AA3		6SL3320-1TG41-3AA3 6SL3325-1TG41-3AA3	
• Rated current of the Motor Module	A	810		910		1025		1270	
• Type rating of the Motor Module	kW	800		900		1000		1200	

¹⁾ The specified power loss represents the maximum value at 100% utilization. The value is lower under normal operating conditions.

Overview

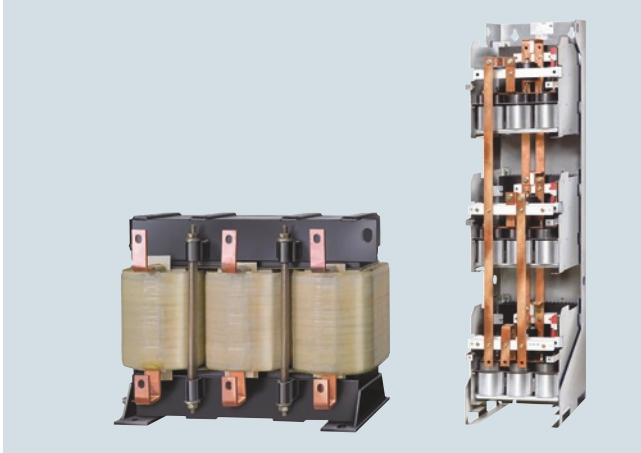

dv/dt filter plus VPL (**V**oltage **P**eak **L**imiter) limit the voltage rate-of-rise dv/dt to values $< 500 \text{ V}/\mu\text{s}$ and the typical voltage peaks to the following values in accordance with the limit value curve according to IEC/TS 60034-17: 2006:

$< 1000 \text{ V}$ at $U_{\text{line}} < 575 \text{ V}$

$< 1250 \text{ V}$ at $660 \text{ V} < U_{\text{line}} < 690 \text{ V}$

Standard motors with standard insulation and without insulated bearings with a supply voltage of up to 690 V can be used for converter operation if a dv/dt filter plus VPL is used.

dv/dt filters plus VPL are designed for the following maximum motor cable lengths:

- Shielded cables: 300 m (e.g. Protodur NYCWY)
- Unshielded cables: 450 m (e.g. Protodur NYY)

For shorter cable lengths (100 m shielded, 150 m unshielded), see also [dv/dt filter compact plus VPL](#).

Notice:

The maximum permissible cable length between the dv/dt filter plus VPL and the Power Module/Motor Module is 5 m.

Design

The dv/dt filter plus VPL consists of two components, which are also supplied as separate mechanical units:

- dv/dt reactor
- Voltage limiting network, which cuts off the voltage peaks and feeds the energy back to the DC link.

SINAMICS S120 Chassis Format Converter Units

System components

Motor-side power components > dv/dt filters plus VPL

Selection and ordering data

Suitable for Power Module		Suitable for Motor Module		Type rating at 400 V kW	Rated output current A	dv/dt filter plus VPL Article No.
Air-cooled	Liquid-cooled	Air-cooled	Liquid-cooled			
Line voltage 380 ... 480 V 3 AC						
6SL3310-1TE32-1AA3	6SL3315-1TE32-1AA3	6SL3320-1TE32-1AA3	6SL3325-1TE32-1AA3	110	210	6SL3000-2DE32-6AA0
6SL3310-1TE32-6AA3	6SL3315-1TE32-6AA3	6SL3320-1TE32-6AA3	6SL3325-1TE32-6AA3	132	260	
6SL3310-1TE33-1AA3	6SL3315-1TE33-1AA3	6SL3320-1TE33-1AA3	6SL3325-1TE33-1AA3	160	310	6SL3000-2DE35-0AA0
6SL3310-1TE33-8AA3	–	6SL3320-1TE33-8AA3	–	200	380	
6SL3310-1TE35-0AA3	6SL3315-1TE35-0AA3	6SL3320-1TE35-0AA3	6SL3325-1TE35-0AA3	250	490	6SL3000-2DE38-4AA0
–	–	6SL3320-1TE36-1AA3	6SL3325-1TE36-1AA3	315	605	
–	–	6SL3320-1TE37-5AA3	6SL3325-1TE37-5AA3	400	745	6SL3000-2DE41-4AA0
–	–	6SL3320-1TE38-4AA3	6SL3325-1TE38-4AA3	450	840	
–	–	6SL3320-1TE41-0AA3	6SL3325-1TE41-0AA3	560	985	6SL3000-2DE41-4AA0
–	–	6SL3320-1TE41-2AA3	6SL3325-1TE41-2AA3	710	1260	
–	–	6SL3320-1TE41-4AA3	6SL3325-1TE41-4AA3	800	1405	6SL3000-2DE41-4AA0
–	–	–	6SL3325-1TE41-4AS3 ¹⁾	800	1330	
Line voltage 500 ... 690 V 3 AC						
–	–	6SL3320-1TG28-5AA3	–	75	85	6SL3000-2DH31-0AA0
–	–	6SL3320-1TG31-0AA3	6SL3325-1TG31-0AA3	90	100	
–	–	6SL3320-1TG31-2AA3	–	110	120	6SL3000-2DH31-5AA0
–	–	6SL3325-1TG31-5AA3	6SL3320-1TG31-5AA3	132	150	
–	–	6SL3320-1TG31-8AA3	–	160	175	6SL3000-2DH32-2AA0
–	–	6SL3320-1TG32-2AA3	6SL3325-1TG32-2AA3	200	215	
–	–	6SL3320-1TG32-6AA3	–	250	260	6SL3000-2DH33-3AA0
–	–	6SL3320-1TG33-3AA3	6SL3325-1TG33-3AA3	315	330	
–	–	6SL3320-1TG34-1AA3	–	400	410	6SL3000-2DH34-1AA0
–	–	6SL3320-1TG34-7AA3	6SL3325-1TG34-7AA3	450	465	
–	–	6SL3320-1TG35-8AA3	6SL3325-1TG35-8AA3	560	575	6SL3000-2DH35-8AA0
–	–	6SL3320-1TG37-4AA3	6SL3325-1TG37-4AA3	710	735	
–	–	6SL3320-1TG38-1AA3	6SL3325-1TG38-0AA3	800	810	6SL3000-2DH38-1AA0
–	–	–	6SL3325-1TG38-1AA3	–	–	
–	–	6SL3320-1TG38-8AA3	–	900	910	6SL3000-2DH41-3AA0
–	–	6SL3320-1TG41-0AA3	6SL3325-1TG41-0AA3	1000	1025	
–	–	6SL3320-1TG41-3AA3	6SL3325-1TG41-3AA3	1200	1270	

¹⁾ This Motor Module has been specifically designed for loads demanding a high dynamic performance.

SINAMICS S120 Chassis Format Converter Units

System components

Motor-side power components > dv/dt filters plus VPL

Technical specifications

Line voltage 380 ... 480 V 3 AC		dv/dt filter plus VPL			
		6SL3000-2DE32-6AA0	6SL3000-2DE35-0AA0	6SL3000-2DE38-4AA0	6SL3000-2DE41-4AA0
I_{th max}	A	260	490	840	1405
Degree of protection		IP00	IP00	IP00	IP00
Cable length, max. between dv/dt filter and motor ¹⁾					
• Shielded	m	300	300	300	300
• Unshielded	m	450	450	450	450
Conformity		CE	CE	CE	CE
Approvals, according to		cURus	cURus	cURus	cURus
dv/dt reactor					
Power loss, max. ²⁾					
• At 50 Hz 400 V	kW	0.701	0.874	1.106	1.111
• At 60 Hz 460 V	kW	0.729	0.904	1.115	1.154
• At 150 Hz 400 V	kW	0.78	0.963	1.226	1.23
Connections					
• To the Power Module/ Motor Module		1 × hole for M10	1 × hole for M12	1 × hole for M12	2 × hole for M12
• To load		1 × hole for M10	1 × hole for M12	1 × hole for M12	2 × hole for M12
• PE		M6 screw	M6 screw	M6 screw	M6 screw
Dimensions					
• Width	mm	410	460	460	445
• Height	mm	370	370	385	385
• Depth	mm	229	275	312	312
Weight, approx.	kg	66	122	149	158
Voltage Peak Limiter (VPL)					
Power loss, max.					
• At 50 Hz 400 V	kW	0.029	0.042	0.077	0.134
• At 60 Hz 460 V	kW	0.027	0.039	0.072	0.125
• At 150 Hz 400 V	kW	0.025	0.036	0.066	0.114
Connections					
• To dv/dt reactor		M8 nut	70 mm ² terminals	1 × hole for M8	1 × hole for M10
• To DC link		M8 nut	70 mm ² terminals	1 × hole for M8	1 × hole for M10
• PE		M8 stud	35 mm ² terminals	M8 stud	M8 stud
Dimensions					
• Width	mm	263	392	309	309
• Height	mm	265	285	1313	1313
• Depth	mm	188	210	400	400
Weight, approx.	kg	6	16	48	72
Suitable for Power Module (Type rating)		6SL3310-1TE32-1AA3 (110 kW) 6SL3315-1TE32-1AA3 (110 kW) 6SL3310-1TE32-6AA3 (132 kW) 6SL3315-1TE32-6AA3 (132 kW)	6SL3310-1TE33-1AA3 (160 kW) 6SL3315-1TE33-1AA3 (160 kW) 6SL3310-1TE33-8AA3 (200 kW) 6SL3310-1TE35-0AA3 (250 kW) 6SL3315-1TE35-0AA3 (250 kW)		
Suitable for Motor Module (Type rating)		6SL3320-1TE32-1AA3 (110 kW) 6SL3325-1TE32-1AA3 (110 kW) 6SL3320-1TE32-6AA3 (132 kW) 6SL3325-1TE32-6AA3 (132 kW)	6SL3320-1TE33-1AA3 (160 kW) 6SL3325-1TE33-1AA3 (160 kW) 6SL3320-1TE33-8AA3 (200 kW) 6SL3320-1TE35-0AA3 (250 kW) 6SL3325-1TE35-0AA3 (250 kW)	6SL3320-1TE36-1AA3 (315 kW) 6SL3325-1TE36-1AA0 (315 kW) 6SL3320-1TE37-5AA0 (400 kW) 6SL3325-1TE37-5AA0 (400 kW) 6SL3320-1TE38-4AA0 (450 kW) 6SL3325-1TE38-4AA0 (450 kW)	6SL3320-1TE41-0AA3 (560 kW) 6SL3325-1TE41-0AA3 (560 kW) 6SL3320-1TE41-2AA3 (710 kW) 6SL3325-1TE41-2AA3 (710 kW) 6SL3320-1TE41-4AA3 (800 kW) 6SL3325-1TE41-4AA3 (800 kW) 6SL3325-1TE41-4AS3 (800 kW) ²⁾

Note:

For power ratings of 560 kW (380 ... 480 V) or 710 kW (500 ... 690 V) and above, a filter contains two dv/dt reactors.

¹⁾ Longer cable lengths for specific configurations are available on request.

The technical specifications listed refer to a dv/dt reactor.

For additional information on dv/dt filters, please refer to the [SINAMICS Low Voltage Engineering Manual](#).

²⁾ This Motor Module has been specifically designed for loads demanding a high dynamic performance.

SINAMICS S120 Chassis Format Converter Units

System components

Motor-side power components > dv/dt filters plus VPL

Technical specifications (continued)

Line voltage 500 ... 690 V 3 AC		dv/dt filter plus VPL			
		6SL3000-2DH31-0AA0	6SL3000-2DH31-5AA0	6SL3000-2DH32-2AA0	6SL3000-2DH33-3AA0
I_{th max}	A	100	150	215	330
Degree of protection		IP00	IP00	IP00	IP00
Cable length, max. between dv/dt filter and motor ¹⁾					
• Shielded	m	300	300	300	300
• Unshielded	m	450	450	450	450
Conformity		CE	CE	CE	CE
Approvals, according to ²⁾		cURus	cURus	cURus	cURus
dv/dt reactor					
Power loss, max.					
• At 50 Hz 500/690 V	kW	0.49	0.389	0.578	0.595
• At 60 Hz 575 V	kW	0.508	0.408	0.604	0.62
• At 150 Hz 500/690 V	kW	0.541	0.436	0.645	0.661
Connections					
• To the Power Module/ Motor Module		1 × hole for M10	1 × hole for M10	1 × hole for M10	1 × hole for M10
• To load		1 × hole for M10	1 × hole for M10	1 × hole for M10	1 × hole for M10
• PE		M6 screw	M6 screw	M6 screw	M6 screw
Dimensions					
• Width	mm	350	350	460	460
• Height	mm	320	320	360	360
• Depth	mm	227	227	275	275
Weight, approx.	kg	48	50	83	135
Voltage Peak Limiter (VPL)					
Power loss, max.					
• At 50 Hz 500/690 V	kW	0.016	0.02	0.032	0.042
• At 60 Hz 575 V	kW	0.015	0.019	0.03	0.039
• At 150 Hz 500/690 V	kW	0.013	0.018	0.027	0.036
Connections					
• To dv/dt reactor		M8 nut	M8 nut	70 mm ² terminals	70 mm ² terminals
• To DC link		M8 nut	M8 nut	70 mm ² terminals	70 mm ² terminals
• PE		M8 stud	M8 stud	35 mm ² terminals	35 mm ² terminals
Dimensions					
• Width	mm	263	263	392	392
• Height	mm	265	265	285	285
• Depth	mm	188	188	210	210
Weight, approx.	kg	6	6	16	16
Suitable for Motor Module (Type rating)		6SL3320-1TG28-5AA3 (75 kW)	6SL3320-1TG31-2AA3 (110 kW)	6SL3320-1TG31-8AA3 (160 kW)	6SL3320-1TG32-6AA3 (250 kW)
		6SL3320-1TG31-0AA3 (90 kW)	6SL3320-1TG31-5AA3 (132 kW)	6SL3320-1TG32-2AA3 (200 kW)	6SL3320-1TG33-3AA3 (315 kW)
		6SL3325-1TG31-0AA3 (90 kW)	6SL3325-1TG31-5AA3 (132 kW)	6SL3325-1TG32-2AA3 (200 kW)	6SL3325-1TG33-3AA3 (315 kW)

Note:

For power ratings of 560 kW (380 ... 480 V) or 710 kW (500 ... 690 V) and above, a filter contains two dv/dt reactors.

The technical specifications listed refer to a dv/dt reactor.
For additional information on dv/dt filters, please refer to the [SINAMICS Low Voltage Engineering Manual](#).

¹⁾ Longer cable lengths for specific configurations are available on request.

²⁾ Only for line voltages 500 ... 600 V 3 AC.

SINAMICS S120 Chassis Format Converter Units

System components

Motor-side power components > dv/dt filters plus VPL

Technical specifications (continued)

Line voltage 500 ... 690 V 3 AC		dv/dt filter plus VPL			
		6SL3000-2DH34-1AA0	6SL3000-2DH35-8AA0	6SL3000-2DH38-1AA0	6SL3000-2DH41-4AA0
I_{th max}	A	410	575	810	1270
Degree of protection		IP00	IP00	IP00	IP00
Cable length, max. between dv/dt filter and motor ¹⁾					
• Shielded	m	300	300	300	300
• Unshielded	m	450	450	450	450
Conformity		CE	CE	CE	CE
Approvals, according to ²⁾		cURus	cURus	cURus	cURus
dv/dt reactor					
Power loss, max.					
• At 50 Hz 500/690 V	kW	0.786	0.862	0.828	0.865
• At 60 Hz 575 V	kW	0.826	0.902	0.867	0.904
• At 150 Hz 500/690 V	kW	0.884	0.964	0.927	0.966
Connections					
• To the Power Module/ Motor Module		1 × hole for M12	1 × hole for M12	2 × hole for M12	2 × hole for M12
• To load		1 × hole for M12	1 × hole for M12	2 × hole for M12	2 × hole for M12
• PE		M6 screw	M6 screw	M6 screw	M6 screw
Dimensions					
• Width	mm	460	460	445	445
• Height	mm	385	385	385	385
• Depth	mm	312	312	312	312
Weight, approx.	kg	147	172	160	164
Voltage Peak Limiter (VPL)					
Power loss, max.					
• At 50 Hz 500/690 V	kW	0.051	0.063	0.106	0.15
• At 60 Hz 575 V	kW	0.048	0.059	0.1	0.14
• At 150 Hz 500/690 V	kW	0.043	0.054	0.091	0.128
Connections					
• To dv/dt reactor		1 × hole for M8	1 × hole for M8	1 × hole for M10	1 × hole for M10
• To DC link		1 × hole for M8	1 × hole for M8	1 × hole for M10	1 × hole for M10
• PE		M8 stud	M8 stud	M8 stud	M8 stud
Dimensions					
• Width	mm	309	309	309	309
• Height	mm	1313	1313	1313	1313
• Depth	mm	400	400	400	400
Weight, approx.	kg	48	48	72	73
Suitable for Motor Module (Type rating)		6SL3320-1TG34-1AA3 (400 kW)	6SL3320-1TG34-7AA3 (450 kW) 6SL3325-1TG34-7AA3 (450 kW) 6SL3320-1TG35-8AA3 (560 kW) 6SL3325-1TG35-8AA3 (560 kW)	6SL3320-1TG37-4AA3 (710 kW) 6SL3325-1TG37-4AA3 (710 kW) 6SL3320-1TG38-1AA3 (800 kW) 6SL3325-1TG38-0AA3 (800 kW) 6SL3325-1TG38-1AA3 (800 kW)	6SL3320-1TG38-8AA3 (900 kW) 6SL3320-1TG41-0AA3 (1000 kW) 6SL3325-1TG41-0AA3 (1000 kW) 6SL3320-1TG41-3AA3 (1200 kW) 6SL3325-1TG41-3AA3 (1200 kW)

Note:
For power ratings of 560 kW (380 ... 480 V) or 710 kW (500 ... 690 V) and above, a filter contains two dv/dt reactors.

The technical specifications listed refer to a dv/dt reactor.
For additional information on dv/dt filters, please refer to the [SINAMICS Low Voltage Engineering Manual](#).

¹⁾ Longer cable lengths for specific configurations are available on request.

²⁾ Only for line voltages 500 ... 600 V 3 AC.

SINAMICS S120 Chassis Format Converter Units

System components

Motor-side power components > dv/dt filters compact plus VPL

Overview



dv/dt filters compact plus VPL (**V**oltage **P**eak **L**imiter) limit the voltage rate-of-rise dv/dt to values of $< 1600 \text{ V}/\mu\text{s}$ and the typical voltage peaks to the following values in accordance with the limit value curve A according to IEC 60034-25: 2007:

$< 1150 \text{ V}$ at $U_{\text{line}} < 575 \text{ V}$

$< 1400 \text{ V}$ at $660 \text{ V} < U_{\text{line}} < 690 \text{ V}$

Standard motors with standard insulation and without insulated bearings with a supply voltage of up to 690 V can be used for converter operation if a dv/dt filter compact plus VPL is used.

dv/dt filters compact plus VPL are designed for the following maximum motor cable lengths:

- Shielded cables: 100 m (e.g. Protodur NYCWY)
- Unshielded cables: 150 m (e.g. Protodur NYY)

For longer cable lengths ($> 100 \text{ m}$ shielded, $> 150 \text{ m}$ unshielded) refer to [dv/dt filter plus VPL](#).

Notice:

- The max. permissible cable length between the dv/dt filter and Motor Module is 5 m
- Operation with output frequencies $< 10 \text{ Hz}$ is permissible for max. 5 min.

Design

The dv/dt filter compact plus VPL consists of two components, which are supplied together as a compact mechanical unit:

- dv/dt reactor
- Voltage limiting network, which cuts off the voltage peaks and feeds the energy back to the DC link

SINAMICS S120 Chassis Format Converter Units

System components

Motor-side power components > dv/dt filters compact plus VPL

Selection and ordering data

Suitable for Motor Module		Type rating at 400 V or 690 V	dv/dt filter compact plus VPL
Air-cooled	Liquid-cooled	kW	Article No.
Line voltage 380 ... 480 V 3 AC			
6SL3320-1TE32-1AA3 6SL3320-1TE32-6AA3	6SL3325-1TE32-1AA3 6SL3325-1TE32-6AA3	110 132	6SL3000-2DE32-6EA0
6SL3320-1TE33-1AA3 6SL3320-1TE33-8AA3 6SL3320-1TE35-0AA3	6SL3325-1TE33-1AA3 6SL3325-1TE35-0AA3	160 200 250	6SL3000-2DE35-0EA0
6SL3320-1TE36-1AA3 6SL3320-1TE37-5AA3 6SL3320-1TE38-4AA3	6SL3325-1TE36-1AA3 6SL3325-1TE37-5AA3 6SL3325-1TE38-4AA3	315 400 450	6SL3000-2DE38-4EA0
6SL3320-1TE41-0AA3 6SL3320-1TE41-2AA3 6SL3320-1TE41-4AA3	6SL3325-1TE41-0AA3 6SL3325-1TE41-2AA3 6SL3325-1TE41-4AA3 6SL3325-1TE41-4AS3 ¹⁾	560 710 800 800	6SL3000-2DE41-4EA0
Line voltage 500 ... 690 V 3 AC			
6SL3320-1TG28-5AA3 6SL3320-1TG31-0AA3	6SL3325-1TG31-0AA3	75 90	6SL3000-2DG31-0EA0
6SL3320-1TG31-2AA3 6SL3320-1TG31-5AA3	6SL3325-1TG31-5AA3	110 132	6SL3000-2DG31-5EA0
6SL3320-1TG31-8AA3 6SL3320-1TG32-2AA3	6SL3325-1TG32-2AA3	160 200	6SL3000-2DG32-2EA0
6SL3320-1TG32-6AA3 6SL3320-1TG33-3AA3	6SL3325-1TG33-3AA3	250 315	6SL3000-2DG33-3EA0
6SL3320-1TG34-1AA3		400	6SL3000-2DG34-1EA0
6SL3320-1TG34-7AA3 6SL3320-1TG35-8AA3	6SL3325-1TG34-7AA3 6SL3325-1TG35-8AA3	450 560	6SL3000-2DG35-8EA0
6SL3320-1TG37-4AA3 6SL3320-1TG38-1AA3	6SL3325-1TG37-4AA3 6SL3325-1TG38-0AA3 6SL3325-1TG38-1AA3	710 800 800	6SL3000-2DG38-1EA0
6SL3320-1TG38-8AA3 6SL3320-1TG41-0AA3 6SL3320-1TG41-3AA3	6SL3325-1TG41-0AA3 6SL3325-1TG41-3AA3	900 1000 1200	6SL3000-2DG41-3EA0

For additional information on dv/dt filters, please refer to the SINAMICS Low Voltage Engineering Manual.

¹⁾ This Motor Module has been specifically designed for loads demanding a high dynamic performance.

SINAMICS S120 Chassis Format Converter Units

System components

Motor-side power components > dv/dt filters compact plus VPL

Technical specifications

Line voltage 380 ... 480 V 3 AC		dv/dt filter compact plus VPL			
		6SL3000-2DE32-6EA0	6SL3000-2DE35-0EA0	6SL3000-2DE38-4EA0	6SL3000-2DE41-4EA0
Rated current	A	260	490	840	1405
$I_{th\ max}$	A	260	490	840	1405
Power loss, max.					
• At 50 Hz 400 V	kW	0.21	0.29	0.518	Reactor: 1.027 VPL: 0.127 Total: 1.154
• At 60 Hz 460 V	kW	0.215	0.296	0.529	Reactor: 1.077 VPL: 0.12 Total: 1.197
• At 150 Hz 400 V	kW	0.255	0.344	0.609	Reactor: 1.354 VPL: 0.09 Total: 1.444
Power connection input and output side		Hole for M10	Hole for M10	Hole for M12	2 × elongated hole, 14 × 18 mm
• Conductor cross section, max. (IEC)		Provided for busbar connection	Provided for busbar connection	Provided for busbar connection	Provided for busbar connection
DC link connection DCPS, DCNS		Threaded socket M8	Threaded socket M8	Hole for M8	Hole for M8
• Conductor cross section, max. (IEC)	mm ²	16	25	50	95
PE/GND connection		Threaded socket M6	Threaded socket M6	Threaded socket M6	Threaded socket M6 (reactor and VPL)
Motor cable length, max.					
• Shielded	m	100	100	100	100
• Unshielded	m	150	150	150	150
Degree of protection		IP00	IP00	IP00	IP00
Dimensions					
• Width	mm	310	350	440	Reactor: 430 VPL: 277
• Height	mm	283	317	369	Reactor: 385 VPL: 360
• Depth	mm	238	260	311	Reactor: 323 VPL: 291
Weight, approx.	kg	41	61	103	Reactor: 168.8 VPL: 19.2 Total: 188
Conformity		CE	CE	CE	CE
Approvals, according to		cURus	cURus	cURus	cURus
Suitable for Motor Module (Type rating)		6SL3320-1TE32-1AA3 (110 kW) 6SL3325-1TE32-1AA3 (110 kW) 6SL3320-1TE32-6AA3 (132 kW) 6SL3325-1TE32-6AA3 (132 kW)	6SL3320-1TE33-1AA3 (160 kW) 6SL3325-1TE33-1AA3 (160 kW) 6SL3320-1TE33-8AA3 (200 kW) 6SL3320-1TE35-0AA3 (250 kW) 6SL3325-1TE35-0AA3 (250 kW)	6SL3320-1TE36-1AA3 (315 kW) 6SL3325-1TE36-1AA3 (315 kW) 6SL3320-1TE37-5AA3 (400 kW) 6SL3325-1TE37-5AA3 (400 kW) 6SL3320-1TE38-4AA3 (450 kW) 6SL3325-1TE38-4AA3 (450 kW)	6SL3320-1TE41-0AA3 (560 kW) 6SL3325-1TE41-0AA3 (560 kW) 6SL3320-1TE41-2AA3 (710 kW) 6SL3325-1TE41-2AA3 (710 kW) 6SL3320-1TE41-4AA3 (800 kW) 6SL3325-1TE41-4AA3 (800 kW) 6SL3325-1TE41-4AS3 (800 kW) ¹⁾

¹⁾ This Motor Module has been specifically designed for loads demanding a high dynamic performance.

SINAMICS S120 Chassis Format Converter Units

System components

Motor-side power components > dv/dt filters compact plus VPL

Technical specifications (continued)

Line voltage 500 ... 690 V 3 AC		dv/dt filter compact plus VPL			
		6SL3000-2DG31-0EA0	6SL3000-2DG31-5EA0	6SL3000-2DG32-2EA0	6SL3000-2DG33-3EA0
Rated current	A	100	150	215	330
$I_{th\ max}$	A	100	150	215	330
Power loss, max.					
• At 50 Hz 500/690 V	kW	0.227	0.27	0.305	0.385
• At 60 Hz 575 V	kW	0.236	0.279	0.316	0.399
• At 150 Hz 500/690 V	kW	0.287	0.335	0.372	0.48
Power connection input and output side		Hole for M10	Hole for M10	Hole for M10	Hole for M10
• Conductor cross section, max. (IEC)		Provided for busbar connection	Provided for busbar connection	Provided for busbar connection	Provided for busbar connection
DC link connection DCPS, DCNS		Threaded socket M8	Threaded socket M8	Hole for M8	Hole for M8
• Conductor cross section, max. (IEC)	mm ²	16	16	25	25
PE/GND connection		Threaded socket M6	Threaded socket M6	Threaded socket M6	Threaded socket M6
Motor cable length, max.					
• Shielded	m	100	100	100	100
• Unshielded	m	150	150	150	150
Degree of protection		IP00	IP00	IP00	IP00
Dimensions					
• Width	mm	310	310	350	350
• Height	mm	283	283	317	317
• Depth	mm	238	238	260	260
Weight, approx.	kg	34	36	51	60
Conformity		CE	CE	CE	CE
Approvals, according to ¹⁾		cURus	cURus	cURus	cURus
Suitable for Motor Module (Type rating)		6SL3320-1TG28-5AA3 (75 kW)	6SL3320-1TG31-2AA3 (110 kW)	6SL3320-1TG31-8AA3 (160 kW)	6SL3320-1TG32-6AA3 (250 kW)
		6SL3320-1TG31-0AA3 (90 kW)	6SL3320-1TG31-5AA3 (132 kW)	6SL3320-1TG32-2AA3 (200 kW)	6SL3320-1TG33-3AA3 (315 kW)
		6SL3325-1TG31-0AA3 (90 kW)	6SL3325-1TG31-5AA3 (132 kW)	6SL3325-1TG32-2AA3 (200 kW)	6SL3325-1TG33-3AA3 (315 kW)

¹⁾ Only for line voltages 500 ... 600 V 3 AC.

SINAMICS S120 Chassis Format Converter Units

System components

Motor-side power components > dv/dt filters compact plus VPL

Technical specifications (continued)

Line voltage 500 ... 690 V 3 AC		dv/dt filter compact plus VPL			
		6SL3000-2DG34-1EA0	6SL3000-2DG35-8EA0	6SL3000-2DG38-1EA0	6SL3000-2DG41-3EA0
Rated current	A	410	575	810	1270
$I_{th\ max}$	A	410	575	810	1270
Power loss, max.					
• At 50 Hz 500/690 V	kW	0.55	0.571	Reactor: 0.88 VPL: 0.084 Total: 0.964	Reactor: 0.926 VPL: 0.124 Total: 1.05
• At 60 Hz 575 V	kW	0.568	0.586	Reactor: 0.918 VPL: 0.08 Total: 0.998	Reactor: 0.993 VPL: 0.111 Total: 1.104
• At 150 Hz 500/690 V	kW	0.678	0.689	Reactor: 1.137 VPL: 0.059 Total: 1.196	Reactor: 1.23 VPL: 0.089 Total: 1.319
Power connection input and output side		Hole for M12	Hole for M12	2 × elongated hole, 14 × 18 mm	2 × elongated hole, 14 × 18 mm
• Conductor cross section, max. (IEC)		Provided for busbar connection	Provided for busbar connection	Provided for busbar connection	Provided for busbar connection
DC link connection DCPS, DCNS		Hole for M8	Hole for M8	Hole for M8	Hole for M8
• Conductor cross section, max. (IEC)	mm ²	50	50	95	95
PE/GND connection		Threaded socket M6	Threaded socket M6	Threaded socket M6 (reactor and VPL)	Threaded socket M6 (reactor and VPL)
Motor cable length, max.					
• Shielded	m	100	100	100	100
• Unshielded	m	150	150	150	150
Degree of protection		IP00	IP00	IP00	IP00
Dimensions					
• Width	mm	440	440	Reactor: 430 VPL: 277	Reactor: 430 VPL: 277
• Height	mm	369	369	Reactor: 385 VPL: 360	Reactor: 385 VPL: 360
• Depth	mm	311	311	Reactor: 323 VPL: 291	Reactor: 323 VPL: 291
Weight, approx.	kg	87	100	Reactor: 171.2 VPL: 18.8 Total: 190	Reactor: 175.8 VPL: 19.2 Total: 195
Conformity		CE	CE	CE	CE
Approvals, according to ¹⁾		cURus	cURus	cURus	cURus
Suitable for Motor Module (Type rating)		6SL3320-1TG34-1AA3 (400 kW)	6SL3320-1TG34-7AA3 (450 kW) 6SL3325-1TG34-7AA3 (450 kW) 6SL3320-1TG35-8AA3 (560 kW) 6SL3325-1TG35-8AA3 (560 kW)	6SL3320-1TG37-4AA3 (710 kW) 6SL3325-1TG37-4AA3 (710 kW) 6SL3320-1TG38-1AA3 (800 kW) 6SL3325-1TG38-0AA3 (800 kW) 6SL3325-1TG38-1AA3 (800 kW)	6SL3320-1TG38-8AA3 (900 kW) 6SL3320-1TG41-0AA3 (1000 kW) 6SL3325-1TG41-0AA3 (1000 kW) 6SL3320-1TG41-3AA3 (1200 kW) 6SL3325-1TG41-3AA3 (1200 kW)

¹⁾ Only for line voltages 500 ... 600 V 3 AC.

SINAMICS S120 Chassis Format Converter Units

System components

Motor-side power components > Sine-wave filters

Overview

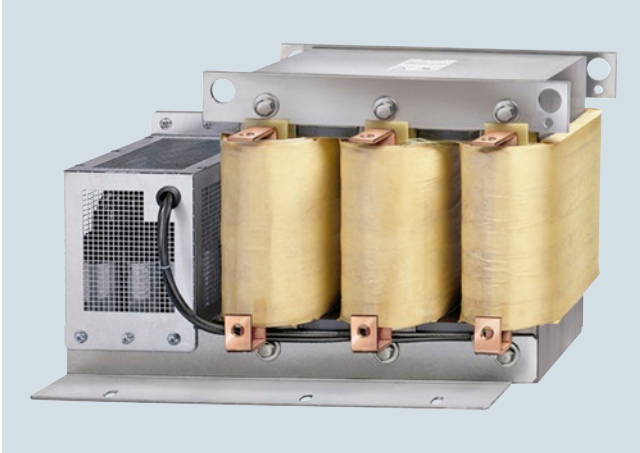

If a sine-wave filter is connected to the output of the Power Module or Motor Module, the voltage between the motor terminals is virtually sinusoidal. This reduces the voltage load on the motor windings and prevents motor noise induced by the pulse frequency.

The pulse frequency of the modules must be set to 4 kHz for the sine-wave filters. The max. output frequency with sine-wave filter is limited to 150 Hz.

As a result, the max. possible output current and the max. achievable output voltage of the units are reduced. The voltage drops across the sine-wave filter, a factor which must also be taken into account in the drive design.

A sine-wave filter must be installed as close as possible to the Motor Module or Power Module.

It is only permissible to operate the sine-wave filter when the motor is connected (sine-wave filters are not no-load proof)!

[For additional information on sine-wave filters, please refer to the SINAMICS Low Voltage Configuration Manual.](#)

Selection and ordering data

Suitable for Power Module		Suitable for Motor Module		Type rating at 400 V kW	Rated output current A	Sine-wave filter Article No.
Air-cooled	Liquid-cooled	Air-cooled	Liquid-cooled			
Line voltage 380 ... 480 V 3 AC						
6SL3310-1TE32-1AA3	6SL3315-1TE32-1AA3	6SL3320-1TE32-1AA3	6SL3325-1TE32-1AA3	110	210	6SL3000-2CE32-3AA0
6SL3310-1TE32-6AA3	6SL3315-1TE32-6AA3	6SL3320-1TE32-6AA3	6SL3325-1TE32-6AA3	132	260	
6SL3310-1TE33-1AA3	6SL3315-1TE33-1AA3	6SL3320-1TE33-1AA3	6SL3325-1TE33-1AA3	160	310	6SL3000-2CE32-8AA0
6SL3310-1TE33-8AA3	–	6SL3320-1TE33-8AA3	–	200	380	6SL3000-2CE33-3AA0
6SL3310-1TE35-0AA3	6SL3315-1TE35-0AA3	6SL3320-1TE35-0AA3	6SL3325-1TE35-0AA3	250	490	6SL3000-2CE34-1AA0

SINAMICS S120 Chassis Format Converter Units

System components

Motor-side power components > Sine-wave filters

Technical specifications

Line voltage 380 ... 480 V 3 AC		Sine-wave filter				
		6SL3000-2CE32-3AA0	6SL3000-2CE32-8AA0	6SL3000-2CE33-3AA0	6SL3000-2CE34-1AA0	
Rated current	A	225	276	333	408	
Power loss, max.						
• At 50 Hz 400 V	kW	0.221	0.235	0.245	0.34	
• At 60 Hz 460 V	kW	0.265	0.282	0.294	0.408	
• At 150 Hz 400 V	kW	0.48	0.5	0.53	0.75	
Load connection		Flat connector for M10 screw	Flat connector for M10 screw	Flat connector for M10 screw	Flat connector for M10 screw	
PE connection		1 × hole for M10	1 × hole for M10	1 × hole for M10	1 × hole for M10	
Cable length, max. between sine-wave filter and motor						
• Shielded	m	300	300	300	300	
• Unshielded	m	450	450	450	450	
Degree of protection		IP00	IP00	IP00	IP00	
Dimensions						
• Width	mm	620	620	620	620	
• Height	mm	300	300	370	370	
• Depth	mm	320	320	360	360	
Weight, approx.	kg	124	127	136	198	
Conformity		CE	CE	CE	CE	
Approvals, according to		cURus	cURus	cURus	cURus	
Suitable for Power Module		6SL3310-1TE32-1AA3 6SL3315-1TE32-1AA3	6SL3310-1TE32-6AA3 6SL3315-1TE32-6AA3	6SL3310-1TE33-1AA3 6SL3315-1TE33-1AA3	6SL3310-1TE33-8AA3	6SL3310-1TE35-0AA3 6SL3315-1TE35-0AA3
Suitable for Motor Module		6SL3320-1TE32-1AA3 6SL3325-1TE32-1AA3	6SL3320-1TE32-6AA3 6SL3325-1TE32-6AA3	6SL3320-1TE33-1AA3 6SL3325-1TE33-1AA3	6SL3320-1TE33-8AA3	6SL3320-1TE35-0AA3 6SL3325-1TE35-0AA3
• Rated current of the Motor Module or Power Module at a pulse frequency of 4 kHz	A	170	215	270	330	380
• Output power of the Motor Module or Power Module at a pulse frequency of 4 kHz	kW	90	110	132	160	200

Overview



CU310-2 PN Control Unit



CU320-2 PN Control Unit

System architecture with a central Control Unit

In multi-axis drives, the individual drives are controlled from the higher-level control systems in such a way as to achieve the desired coordinated movement. This requires cyclic data exchange between the controller and the drives. A central Control Unit controls the drives for all connected axes and also establishes the technological links between the drives and/or axes. Since all the required data is stored in the central Control Unit, it does not need to be transferred. Inter-axis connections can be established within a Control Unit and easily configured in the STARTER commissioning tool using a mouse.

- The SINAMICS control module can handle simple technological tasks by itself
- The **CU320-2 DP** or **CU320-2 PN** Control Units are used in conjunction with all Motor Modules or Line Modules for single or multi-motor drives. The **CU310-2 DP** or **CU310-2 PN** Control Units are used together with the Power Modules and single-motor drives.
- Sophisticated motion control tasks can be implemented with the support of the more powerful **D410-2**, **D425-2**, **D435-2**, and **D445-2** Control Units of **SIMOTION D** (graded according to performance). Refer to [Catalog PM 21](#) for information about SIMOTION.

Each Control Unit is based on an object-oriented SINAMICS standard firmware, which contains all common control modes and can be scaled to meet even the most advanced performance requirements.

The drive controls are supplied as ready-to-configure drive objects:

- Infeed Control for mains infeed
- Vector control
 - Speed-controlled drives with high speed and torque stability in general machine and plant construction
 - Particularly suitable for induction motors
 - Optimized pulse patterns for efficient motor/converter systems
- Servo control
 - Drives with highly dynamic motion control
 - Angular-locked synchronism with isochronous PROFIBUS/PROFINET
 - For use in machine tools and clocked production machines

The most commonly used V/f control modes are stored in the "Vector control" drive object and are ideal for implementing even simple applications such as group drives with SIEMOSYN motors.

SINAMICS S120 Chassis Format Converter Units

System components

Control Units

Overview (continued)

Overview of key open-loop and closed-loop control functions

	Closed-loop control types S120	Open-loop control types S120	Main functions S120 for booksize/chassis	Comment, note
Infeed Control	<ul style="list-style-type: none"> Chassis Current control with VSM10 V_{DC} control with VSM10 Network functionalities (island grids) 	<ul style="list-style-type: none"> Booksize/chassis Basic Mode Rectification only Smart Mode Rectification and regenerative feedback 	<ul style="list-style-type: none"> Mains identification Controller optimization Harmonics filter Automatic restart 	The VSM10 is the Voltage Sensing Module; "current" is the line current; 3-phase with line frequency
Vector control	<ul style="list-style-type: none"> Induction motor Torque control with/without encoder Speed control with/without encoder Torque motor Torque control with encoder Speed control with/without encoder For induction and torque motors Position control with encoder 	<ul style="list-style-type: none"> Linear V/f characteristic Constant-frequency V/f characteristic (textile) Independent voltage setpoint input 	<ul style="list-style-type: none"> Data set changeover Extended setpoint input Motor identification Current/speed controller optimization Technology controller Basic positioner Automatic restart Flying restart with/without encoder Kinetic buffering Synchronization Droop Brake control 	<p>Mixed operation with V/f control modes is possible; it is for this reason that the V/f control modes are stored only once in the "Vector control" drive object</p> <p>Position control can be selected as a function module from both Servo and Vector mode</p> <p>Permanent-magnet 1FW4 synchronous motors can be operated over the complete operating range in <u>Vector control</u>.</p>
Servo control	<ul style="list-style-type: none"> Induction motor Torque control with/without encoder Speed control with/without encoder Synchronous motor, linear motor and torque motor Torque control with encoder Speed control with encoder For all motor types Position control with encoder 	<ul style="list-style-type: none"> Linear V/f characteristic Constant-frequency V/f characteristic (textile) Independent voltage setpoint input 	<ul style="list-style-type: none"> Data set changeover Setpoint input Motor identification Damping application Technology controller Basic positioner Brake control 	<p>Mixed operation with V/f control modes is possible; it is for this reason that the V/f control modes are stored only once in the "Vector control" drive object</p> <p>Position control can be selected as a function module from both Servo and Vector mode.</p>

Drive objects

A drive object is a self-contained software function with its own parameters and, where appropriate, its own fault messages and alarms.

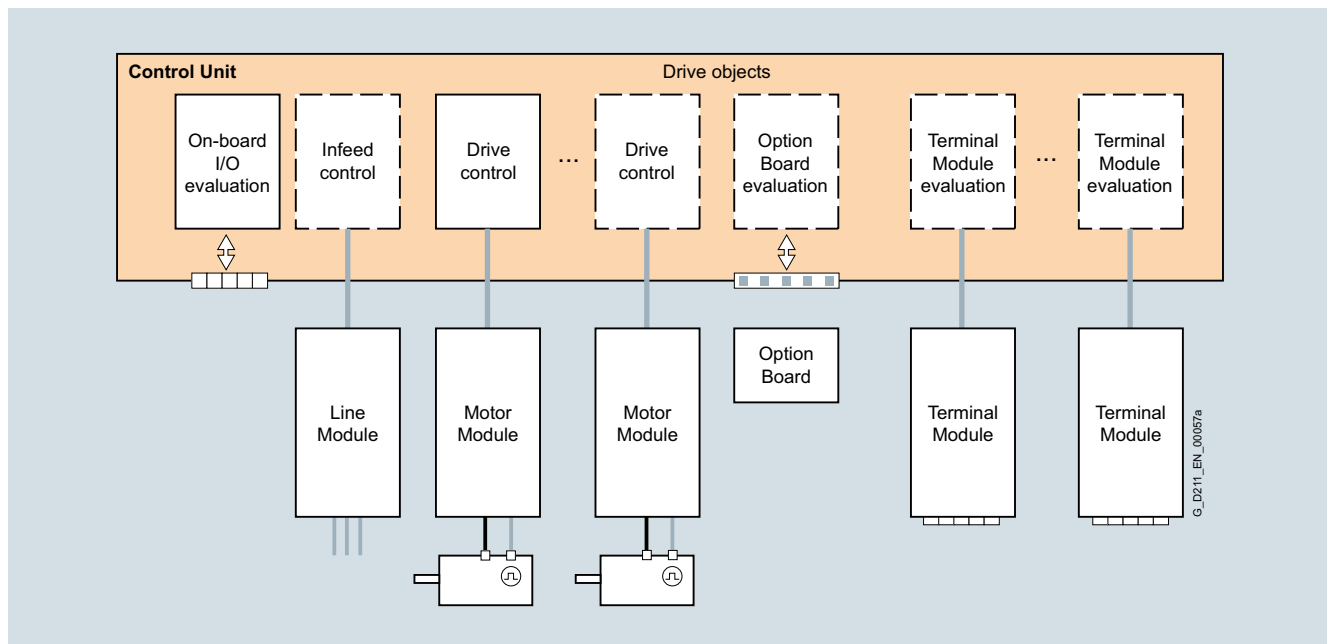

Overview (continued)

Comprehensive package of open-loop and closed-loop control functions

A wide variety of standard functions such as setpoint input, data set changeover, controller optimization, kinetic buffering, etc. ensure a high degree of functional reliability and excellent flexibility when addressing the application.

BICO technology

Every drive object contains a large number of input and output variables which can be freely and independently interconnected using Binector Connector Technology (BICO). A binector is a logic signal which can assume the value 0 or 1. A connector is a numerical value, e.g. the actual speed or current setpoint.

Drive Control Chart (DCC)

Drive Control Chart (DCC) for SINAMICS S120 is a user-friendly tool with which drive-related closed-loop control, logic and arithmetic functions can be configured in graphical form. It extends the possibility of configuring technological functions for SINAMICS drives in an extremely easy way.

The user-friendly DCC editor enables easy graphics-based configuration, allows control loop structures to be clearly represented and provides a high degree of reusability of charts that have already been created.

The associated block library (DCB library) contains a large selection of closed-loop control, calculation and logic modules (Drive Control Blocks (DCB)) as well as more complex open-loop and closed-loop control functions.

Two types of DCB library are available, i.e. DCB Standard and DCB Extension. The DCB standard library is supplied as standard with the SINAMICS DCC software.

DCC is an add-on for the STARTER commissioning tool.

CompactFlash card

The functions of the drives are stored on a CompactFlash card. This card contains the firmware and parameter settings for all drives in the form of a project. The CompactFlash card can also hold additional projects, which means that the correct project can be accessed immediately when series machines of different types are commissioned. When the Control Unit has booted, the data on the CompactFlash card is read and loaded to the RAM.

The firmware is organized in objects. Drive objects are used to implement open-loop and closed-loop control functions for Line Modules, Motor Modules, Power Modules and other system components connected by DRIVE-CLiQ.

Integral safety functions (Safety Integrated)

The Control Units support comprehensive safety functions.

The integrated safety functions are the Safety Integrated Basic functions

- STO = Safe Torque Off
- SBC = Safe Brake Control
- SS1 = Safe Stop 1 (Time controlled)

and the Safety Integrated Extended functions that require a license

- SS1 = Safe Stop 1 (time and acceleration controlled)
- SS2 = Safe Stop 2
- SOS = Safe Operating Stop
- SLS = Safely-Limited Speed
- SSM = Safe Speed Monitor
- SDI = Safe Direction
- SLP = Safely-Limited Position
- SP = Safe Position transmission
- SBT = Safe Brake Test

If the integrated safety functions are used, licenses, supplementary system components such as TM54F Terminal Modules, or suitable safety controls will be necessary.

Diagnostics optimally supported by trace function

The time characteristics of input and output variables associated with drive objects can be measured by the integrated trace function and displayed using the STARTER commissioning tool. Several signals can be simultaneously traced. A recording can be triggered dependent on freely selectable boundary conditions, e.g. the value of an input or output variable.

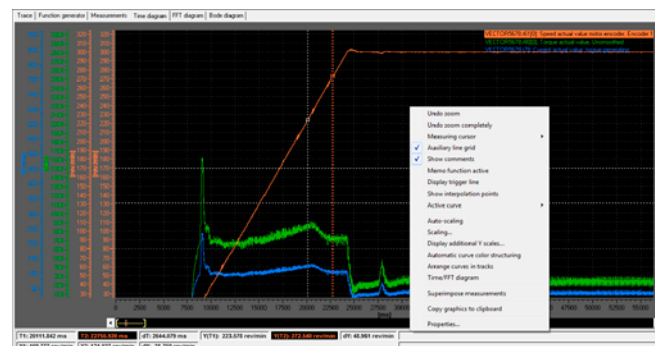

SINAMICS S120 Chassis Format Converter Units

System components

Control Units > CU320-2 Control Unit

Overview



CU320-2 PN and CU320-2 DP Control Units

The communication, open-loop and closed-loop control functions for one or more Line Modules and/or Motor Modules are executed in a CU320-2 Control Unit. The CU320-2 Control Unit is essentially designed for multi-axis operation. Communication with the higher-level control system is performed via PROFIBUS DP or PROFINET.

Design

CU320-2 Control Units feature the following interfaces as standard:

- Fieldbus interface:
 - CU320-2 PN: 1 PROFINET interface with 2 ports (RJ45 sockets) with PROFIdrive V4 profile
 - CU320-2 DP: 1 PROFIBUS interface with PROFIdrive V4 profile
- 4 x DRIVE-CLiQ sockets for communication with other DRIVE-CLiQ nodes, e.g. Motor Modules, Active Line Modules, Sensor Modules, Terminal Modules
- 12 parameterizable digital inputs (floating)
- 8 parameterizable bidirectional digital inputs/digital outputs (non-floating)
- 1 serial RS 232 interface (e.g. to connect the AOP30 Advanced Operator Panel)
- 1 interface for the BOP20 Basic Operator Panel
- 1 slot for the CompactFlash card on which firmware and parameters are stored
- 1 slot for mounting an option module (e.g. TB30 Terminal Board)
- 2 rotary coding switches for manually setting the PROFIBUS address
- 1 Ethernet interface for commissioning and diagnostics
- 3 measuring sockets and one reference ground for commissioning support
- 1 connection for the electronics power supply via the 24 V DC supply connector
- 1 PE/protective conductor connector
- 1 ground connection

A shield connection for the signal cable shield of the option module is located on the CU320-2 Control Unit.

The available option slot is used to expand the interfaces, for example, to include additional terminals or for communication purposes.

The status of the CU320-2 Control Unit is indicated via multi-color LEDs.

As the firmware and parameter settings are stored on a plug-in CompactFlash card, the Control Unit can be changed without the need for software tools.

The CU320-2 Control Unit can be mounted on the side of the Line Module via brackets integrated in a Line Module. The CU320-2 Control Unit can also be fixed to the wall of the control cabinet using the integrated fixing lugs.

SINAMICS S120 Chassis Format Converter Units

System components

Control Units > CU320-2 Control Unit

Selection and ordering data

Description	Article No.
CU320-2 PN Control Unit Without CompactFlash Card	6SL3040-1MA01-0AA0
CU320-2 DP Control Unit Without CompactFlash Card	6SL3040-1MA00-0AA0
Accessories	
For CU320-2 PN: Industrial Ethernet FC	
• RJ45 Plug 145 (1 units)	6GK1901-1BB30-0AA0
• RJ45 Plug 145 (10 units)	6GK1901-1BB30-0AB0
• Stripping tool	6GK1901-1GA00
• Standard cable GP 2x2	6XV1840-2AH10
• Flexible cable GP 2x2	6XV1870-2B
• Trailing cable GP 2x2	6XV1870-2D
• Trailing cable 2x2	6XV1840-3AH10
• Marine cable 2x2	6XV1840-4AH10
For CU320-2 DP: PROFIBUS connector	
• <u>Without</u> PG/PC connection	6ES7972-0BA42-0XA0
• <u>With</u> PG/PC connection	6ES7972-0BB42-0XA0
Spacers (2 units) Increases the depth of the CU320-2 DP Control Unit to 270 mm (if the integrated brackets are not to be used, but the depth still has to be 270 mm)	6SL3064-1BB00-0AA0
STARTER commissioning tool	6SL3072-0AA00-0AG0
Accessories for re-ordering	
Dust protection blanking plugs (50 units) For DRIVE-CLiQ port	6SL3066-4CA00-0AA0

Integration

DRIVE-CLiQ components, for example, Motor Modules and Active Line Modules, can be connected to a CU320-2 Control Unit. The number of modules depends on the performance required, including duty type and additional functions.

The BOP20 Basic Operator Panel can also be snapped onto the CU320-2 Control Unit during operation for diagnostic purposes.

The CU320-2 Control Unit and other connected components are commissioned and diagnosed with the STARTER commissioning tool and the installed SINAMICS Support Package or the AOP30 Advanced Operator Panel.

The CU320-2 PN Control Unit requires a CompactFlash card with firmware V4.4 or higher.

The CU320-2 DP Control Unit requires a CompactFlash card with firmware V4.3 or higher.

SINAMICS S120 Chassis Format Converter Units

System components

Control Units > CU320-2 Control Unit

Integration (continued)

3

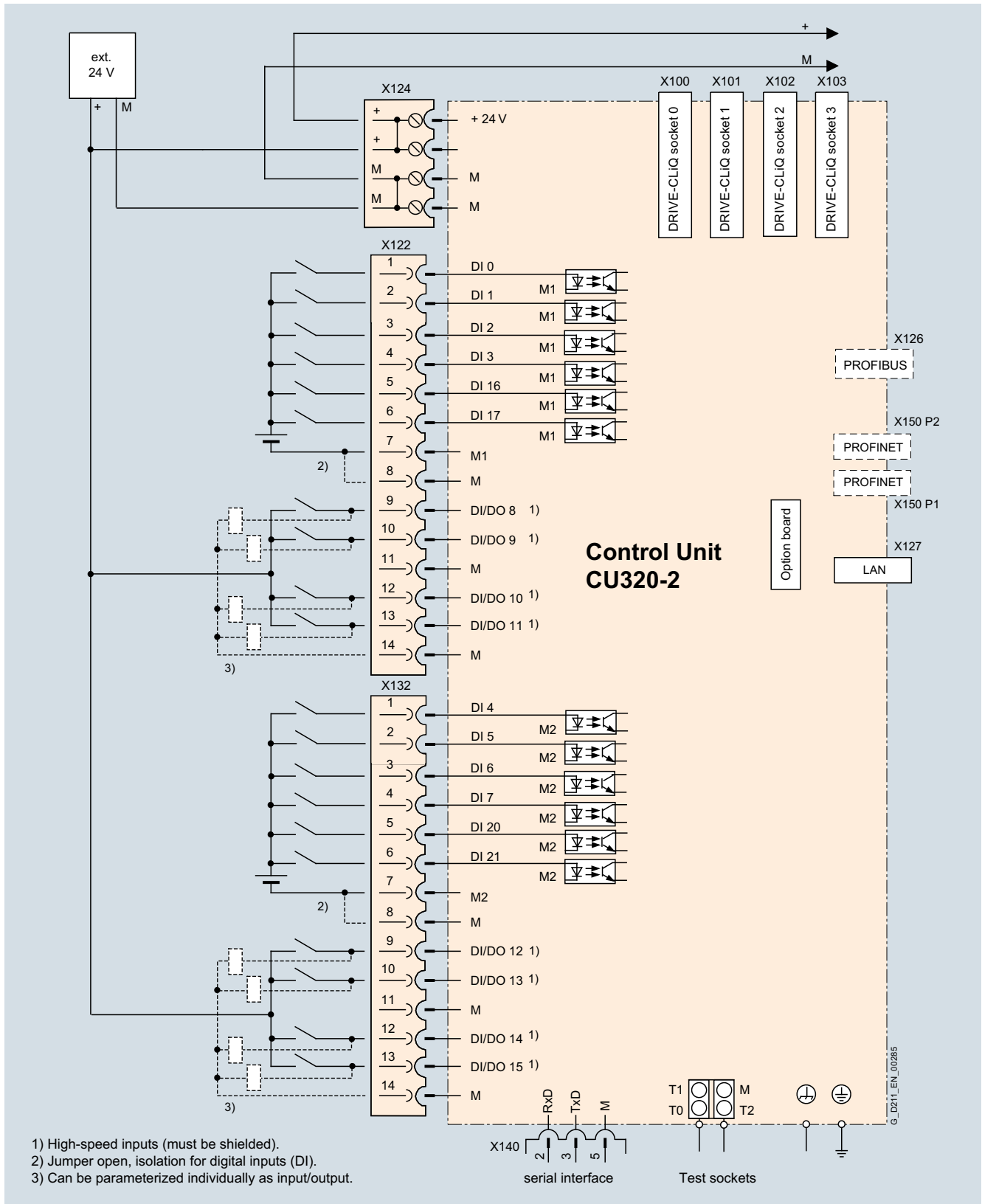

Connection example of a CU320-2 Control Unit

Technical specifications

CU320-2 Control Unit

PROFINET: 6SL3040-1MA01-0AA0
PROFIBUS: 6SL3040-1MA00-0AA0

Power requirement, max.

At 24 V DC,
without taking account of digital outputs, expansion option slot and
DRIVE-CLiQ supply

1 A

Conductor cross-section, max.

2.5 mm²

Fuse protection, max.

20 A

Digital inputs

In accordance with IEC 61131-2 Type 1
12 floating digital inputs
8 bidirectional non-floating digital inputs/outputs

- Voltage
- Low level (an open digital input is interpreted as "low")
- High level
- Current consumption at 24 V DC, typ.
- Delay time of digital inputs ¹⁾, approx.
 - L → H
 - H → L
- Delay time of high-speed digital inputs ¹⁾, approx.
 - L → H
 - H → L
- Conductor cross-section, max.

-3 ... +30 V

-3 ... +5 V

15 ... 30 V

9 mA

50 μs

100 μs

5 μs

50 μs

1.5 mm²

Digital outputs

8 bidirectional non-floating digital inputs/outputs

Continuously short-circuit proof

- Voltage
- Load current per digital output, max.
- Delay time ¹⁾, typ./max.
 - L → H
 - H → L
- Conductor cross-section, max.

24 V DC

500 mA

150 μs / 400 μs

75 μs / 100 μs

1.5 mm²

Power loss

24 W

PE connection

M5 screw

Ground connection

M5 screw

Dimensions

- Width
- Height
- Depth

50 mm

300 mm

226 mm

Weight, approx.

2.3 kg

¹⁾ The specified delay times refer to the hardware. The actual reaction time depends on the time slice in which the digital input or output is processed.

SINAMICS S120 Chassis Format Converter Units

System components

Control Units > CompactFlash card for CU320-2

Overview



The CompactFlash card contains the firmware and set parameters. The CompactFlash card is inserted into the appropriate slot of the CU320-2 Control Unit.

Design

A CU320-2 Control Unit can perform the communication, open-loop and closed-loop control functions for several power units. The computing capacity requirement increases in proportion to the number of power units and system components and in relation to the dynamic response required. The computing capacity requirement and utilization of the CU320-2 Control Unit can be calculated with the SIZER for Siemens Drives engineering tool. The full computing capacity of the CU320-2 Control Unit is only available on systems with performance expansion. For the CU320-2 Control Unit, the performance expansion is necessary for machines with 4 axes or more.

In addition to the firmware, the CompactFlash card also contains license keys which are required to enable firmware options, e.g. for the performance expansion and the Safety Integrated extended functions. The Safety Integrated extended functions must be ordered for each axis via order codes (**F.**) in addition to the article number.

Converter cabinets with a Control Unit already contain the CompactFlash card with the current firmware. The firmware licenses can be added as a cabinet option.

The firmware options can also be enabled later, for example, if the performance expansions required are not known at the time of placing the order or the Safety Integrated Extended Functions are to be enabled retrospectively. You require the serial number of the CompactFlash card and the article number of the firmware option to be enabled. With this information, you can purchase the associated license code from a license database and enable the firmware option. The license code is only valid for the CompactFlash card declared and cannot be transferred to other CompactFlash cards.

Subsequent licensing is possible in the Internet via the WEB License Manager by generating a license key:
www.siemens.com/automation/license

Selection and ordering data

Description	Article No.
CompactFlash card for CU320-2 Control Unit without Safety license	
• <u>Without</u> performance expansion	6SL3054-0E□00-1BA0
• <u>With</u> performance expansion firmware option	6SL3054-0E□01-1BA0
CompactFlash card for CU320-2 Control Unit with Safety license	
• For 1 axis	6SL3054-0E□0□-1BA0-Z F01
• For 2 axes	6SL3054-0E□0□-1BA0-Z F02
• For 3 axes	6SL3054-0E□0□-1BA0-Z F03
• For 4 axes	6SL3054-0E□01-1BA0-Z F04
• For 5 axes	6SL3054-0E□01-1BA0-Z F05
• For 6 axes	6SL3054-0E□01-1BA0-Z F06
<u>Version</u>	↑
	D
.3	E
.4	F
.5	G
.6	H
.7	J
.8	K
.9	↑
<u>Without</u> performance expansion	0
<u>With</u> performance expansion firmware option	1
Firmware license	
• Performance expansion option including Certificate of License for upgrading the license of a CompactFlash card	6SL3074-0AA01-0AA0
• Safety Integrated Extended Functions option including Certificate of License for one axis for upgrading the license of a CompactFlash Card. This option must be ordered once for each axis, e.g. a maximum of 6 times for a CompactFlash Card	6SL3074-0AA10-0AA0
• SINAMICS DCB extension option Runtime license as of firmware V 4.6 including Certificate of License for upgrading the license of a CompactFlash card (see Section Tools and configuration, SINAMICS Drive Control Chart engineering software).	6SL3077-0AA00-0AB0

More information

Firmware version

The firmware version is encoded as follows in the article number printed on the CompactFlash card:

Article No.:	6SL3054-0□□□-1BA0	
Firmware version		↑
	4	E
Version		↑
	.1	B
	.2	C
	.3	D
	.4	E
	.5	F
	.6	G
	.7	H
	.8	I
	.9	K
		↑
Without performance expansion		0
With performance expansion		1

A firmware version of ≥ 4.3 is required for the CU320-2 Control Unit.

The current firmware version at the time of publication of this catalog is version 4.7.

SINAMICS S120 Chassis Format Converter Units

System components

Control Units > CU310-2 Control Unit

Overview



CU310-2 PN and CU310-2 DP Control Units

The CU310-2 Control Unit for the communication and open-loop/closed-loop control functions of a Power Module is combined with the Power Module to create a powerful single drive. A PROFINET (PN) variant and a PROFIBUS (DP) variant are available for fieldbus communication.

Design

CU310-2 Control Units feature the following interfaces as standard:

- Fieldbus interface
 - CU310-2 PN:
 - 1 PROFINET interface with 2 ports (RJ45 sockets) with PROFIdrive V4 profile
 - CU310-2 DP:
 - 1 PROFIBUS interface with PROFIdrive V4 profile
- 1 DRIVE-CLiQ socket to allow communication with other DRIVE-CLiQ nodes
- 1 encoder evaluation for evaluating the following encoder signals
 - Incremental encoder TTL/HTL
 - SSI encoders without incremental signals
- 6 parameterizable digital inputs (isolated) or alternatively 3 parameterizable, fail-safe digital inputs (isolated, can be used with firmware V4.5 and higher).
The fail-safe digital inputs can be routed, i.e. they can be routed via PROFIsafe to a higher-level controller.
- 1 digital output (isolated) or alternatively 1 parameterizable, fail-safe digital output (isolated, can be used with firmware V4.5 or higher)
- 5 parameterizable digital inputs (floating)
- 8 parameterizable bidirectional digital inputs/digital outputs (non-floating)
- 1 analog input, either ± 10 V (resolution 12 bits + sign) or ± 20 mA (11 bits + sign)
- 1 Ethernet interface (RJ45 socket) for commissioning and diagnostics
- 1 serial RS232 interface
- 1 connection for the electronics power supply via the 24 V DC supply connector
- 1 temperature sensor input (KTY84-130 or PTC)
- 3 measuring sockets and one reference ground for commissioning support
- 1 slot for the CompactFlash card on which firmware and parameters are stored
- 1 PM-IF interface for communication with Power Modules in blocksize format
- 1 interface to the BOP20 Basic Operator Panel
- 1 PE connection

The status of the CU310-2 Control Unit is indicated via multi-color LEDs.

A BOP20 Basic Operator Panel can also be snapped directly onto the CU310-2 Control Unit for diagnostic procedures.

As the firmware and parameter settings are stored on a plug-in CompactFlash card, the Control Unit can be changed without the need for software tools.

SINAMICS S120 Chassis Format Converter Units

System components

Control Units > CU310-2 Control Unit

Selection and ordering data

Description	Article No.
CU310-2 DP Control Unit Without CompactFlash Card	6SL3040-1LA00-0AA0
CU310-2 PN Control Unit Without CompactFlash Card	6SL3040-1LA01-0AA0
<i>Accessories</i>	
For CU310-2 PN:	
Industrial Ethernet FC	
• RJ45 plug 180 (1 unit)	6GK1901-1BB10-2AA0
• RJ45 plug 180 (10 units)	6GK1901-1BB10-2AB0
• Stripping tool	6GK1901-1GA00
• Standard cable GP 2x2	6XV1840-2AH10
• Flexible cable GP 2x2	6XV1870-2B
• Trailing cable GP 2x2	6XV1870-2D
• Trailing cable 2x2	6XV1840-3AH10
• Marine cable 2x2	6XV1840-4AH10
For CU310-2 DP:	
PROFIBUS connector	
• <u>Without</u> PG/PC connection	6ES7972-0BA42-0XA0
• <u>With</u> PG/PC connection	6ES7972-0BB42-0XA0
STARTER commissioning tool	6SL3072-0AA00-0AG0
<i>Accessories for re-ordering</i>	
Dust protection blanking plugs (50 units) For DRIVE-CLiQ port	6SL3066-4CA00-0AA0

For more information on connectors and cables, please refer to Catalog IK PI and the Siemens Industry Mall:
www.siemens.com/industrymall

Integration

Power Modules in chassis format are controlled from the CU310-2 Control Unit via the DRIVE-CLiQ interface. Sensor Modules and Terminal Modules must be connected to the free DRIVE-CLiQ sockets of the Power Module.

Parameter settings can be changed directly via the BOP20 Basic Operator Panel. The BOP20 Basic Operator Panel can also be snapped onto the CU310-2 Control Unit during operation to perform diagnostics.

The CU310-2 Control Unit and other connected components are commissioned and diagnosed with the STARTER commissioning tool.

A CU310-2 DP Control Unit communicates with the higher-level control system using PROFIBUS and the PROFIdrive V4 profile.

A CU310-2 PN Control Unit communicates with the higher-level control system using PROFINET IO and the PROFIdrive V4 profile.

The SINAMICS S120 drive system with the CU310-2 PN Control Unit then assumes the function of a PROFINET IO device and can perform the following functions:

- PROFINET IO device
- 100 Mbit/s full duplex
- Supports real-time classes of PROFINET IO:
 - RT (Real-Time)
 - IRT (Isochronous Real-Time), minimum send cycle 500 µs
- Connects to controls as PROFINET IO devices using PROFIdrive compliant with Specification V4
- Standard TCP/IP communication for engineering processes using the STARTER commissioning tool
- Integrated 2-port switch with two RJ45 sockets based on the ERTEC ASIC. The optimum topology (line, star, tree) can therefore be configured without additional external switches.

A 24 V supply voltage must be connected to terminal X124 for the digital outputs to be used. The CU310-2 Control Unit requires a CompactFlash card with firmware V4.5 or higher.

SINAMICS S120 Chassis Format Converter Units

System components

Control Units > CU310-2 Control Unit

Integration (continued)

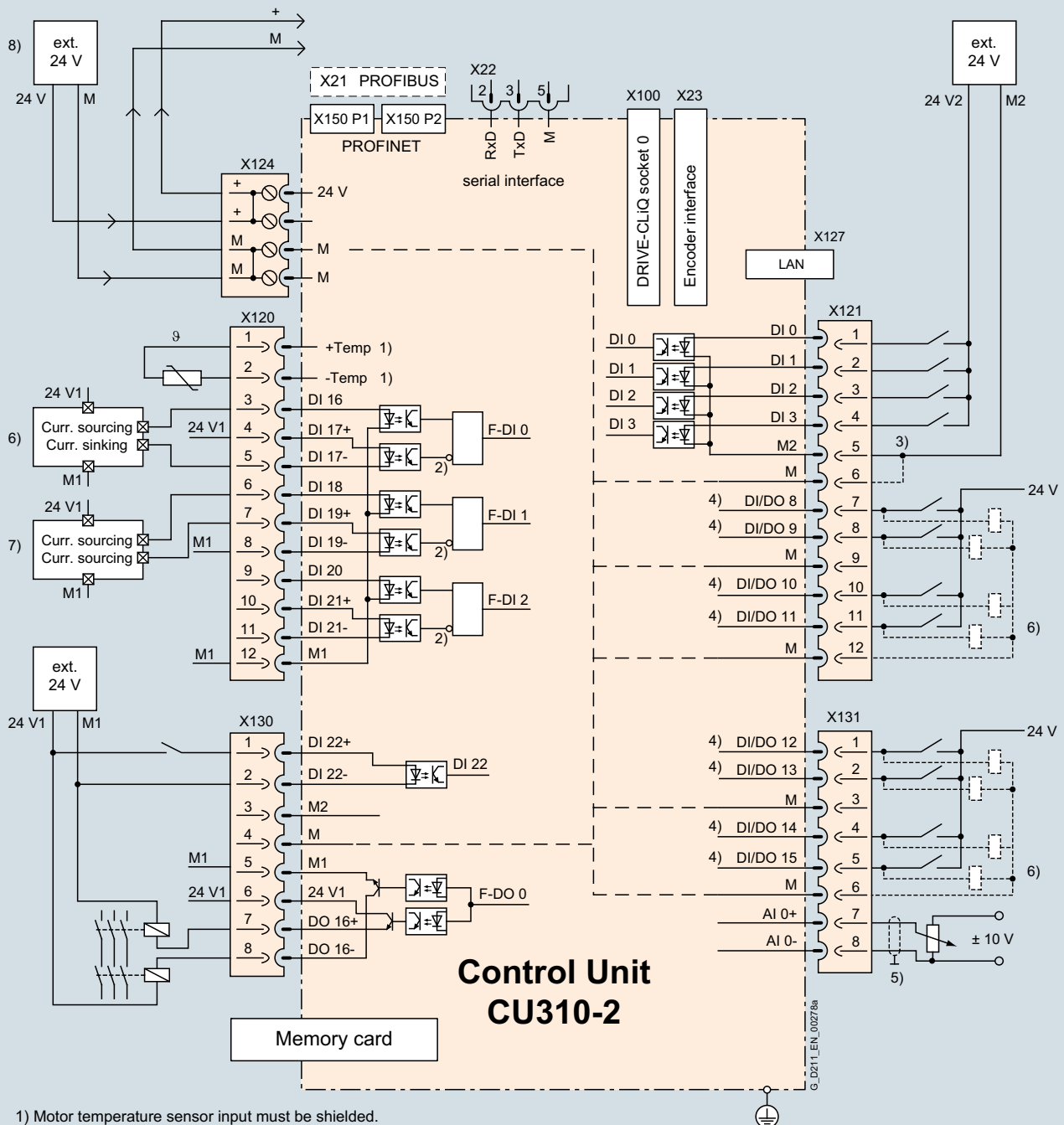

- 1) Motor temperature sensor input must be shielded.
- 2) Inversion can be parameterized.
- 3) Jumper open, isolation for digital inputs (DI).
- 4) High-speed inputs must be shielded.
- 5) Analog input must be shielded.
- 6) Safety-related control with current sourcing and current sinking outputs.
- 7) Safety-related control with two current sourcing outputs.
- 8) In order to use the digital outputs, an external 24 V power supply must be connected to terminal X124.

Connection example of CU310-2 Control Unit

SINAMICS S120 Chassis Format Converter Units

System components

Control Units > CU310-2 Control Unit

Technical specifications

CU310-2 Control Unit

PROFINET: 6SL3040-1LA01-0AA0
 PROFIBUS: 6SL3040-1LA00-0AA0

Power requirement, max.
 At 24 V DC,
 without taking into account the digital outputs and DRIVE-CLiQ supply

0.35 A for CU310 DP Control Unit + 0.5 A for PM340 Power Module

Conductor cross-section, max.

2.5 mm²

Fuse protection, max.

20 A

Digital inputs

in accordance with IEC 61131-2 Type 1
 5 floating digital inputs
 8 bidirectional non-floating digital inputs/outputs
 3 parameterizable, fail-safe digital inputs (isolated) or alternatively
 6 parameterizable digital inputs (isolated)

- Voltage
- Low level (an open digital input is interpreted as "low")
- High level
- Current consumption at 24 V DC, typ.
- Delay time of digital inputs ¹⁾, approx.
 - L → H
 - H → L
- Delay time of high-speed digital inputs ¹⁾, approx.
 (high-speed digital inputs can be used for position detection)
 - L → H
 - H → L
- Conductor cross-section, max.

-3 ... +30 V

-3 ... +5 V

15 ... 30 V

10 mA

50 μs

100 μs

5 μs

50 μs

1.5 mm²

Digital outputs

Continuously short-circuit proof

8 bidirectional non-floating digital inputs/outputs

- Voltage
- Load current per digital output ²⁾, max.
- Delay time ¹⁾, typ./max.
 - L → H
 - H → L
- Conductor cross-section, max.

24 V DC

500 mA

150 μs/400 μs

75 μs/100 μs

1.5 mm²

Analog input

- Voltage
- Current
- Max. range that can be resolved
- Common mode range
- Resolution

1 analog input for current or voltage input, switchable

-10 ... +10 V; $R_i > 100 \Omega$ -20 ... +20 mA; $R_i > 250 \Omega$

-11 ... +11 V

±12 V

13 bits (with respect to the maximum range that can be resolved)

Encoder evaluation

- Input impedance
 - TTL
 - HTL, max.
- Encoder supply
- Encoder frequency, max.
- SSI baud rate
- Resolution absolute position SSI
- Cable length, max.
 - TTL encoder
 - HTL encoder
 - SSI encoder

- Incremental encoder TTL/HTL
- SSI encoders without incremental signals

570 Ω

16 mA

24 V DC / 0.35 A or
5 V DC / 0.35 A

300 kHz

100 ... 250 kBaud

30 bits

100 m (only bipolar signals permitted) ³⁾

100 m for unipolar signals

300 m for bipolar signals ³⁾

100 m

Power loss

<20 W

PE connection

M5 screw

Dimensions

- Width
- Height
- Depth

73 mm

75 mm

Weight, approx.

0.95 kg

¹⁾ The specified delay times refer to the hardware. The actual reaction time depends on the time slice in which the digital input or output is processed.

²⁾ In order to use the digital outputs, an external 24 V power supply must be connected to terminal X124.

³⁾ Signal cables twisted in pairs and shielded.

SINAMICS S120 Chassis Format Converter Units

System components

Control Units > CompactFlash card for CU310-2

Overview



The CompactFlash card contains the firmware and set parameters. The CompactFlash card is plugged into the appropriate slot on the CU310-2 Control Unit.

Design

A CU310-2 Control Unit can perform the communication, open-loop and closed-loop control functions for one Power Module. The performance expansion is not required in this case.

In addition to the firmware, the CompactFlash card also contains licensing codes which are required to enable firmware options (currently the Safety Integrated Extended Functions). To order the Safety Integrated Extended Functions (Safe Stop 2, Safe Operating Stop, Safely-Limited Speed, Safe Speed Monitor), order codes (**F01**) must be stated in addition to the Article No. for each axis.

The firmware options can also be enabled later, for example, if, at the time the order is placed, the intention is to enable Safety Integrated Extended Functions at a later time. You will need the serial number of the CompactFlash card and the Article No. of the firmware option to be enabled. With this information, you can purchase the associated license code from a license database and enable the firmware option. The license code is only valid for the CompactFlash card declared and cannot be transferred to other CompactFlash cards.

Subsequent licensing is possible in the Internet via the WEB License Manager by generating a license key:
www.siemens.com/automation/license

Selection and ordering data

Description	Article No.
CompactFlash card for CU310-2 DP, CU310-2 PN Control Units without safety license	6SL3054-0E□00-1BA0
CompactFlash card for CU310-2 DP, CU310-2 PN Control Units with safety license • including Certificate of License	6SL3054-0E□00-1BA0-Z F01
<u>Firmware version</u>	↑
Version	.4 .5 .6 .7 .8 .9
	E F G H J K
Firmware license	6SL3074-0AA10-0AA0
Safety Integrated Extended Functions option including Certificate of License for one axis for upgrading the license of a CompactFlash Card.	

SINAMICS S120 Chassis Format Converter Units

System components

Supplementary system components > BOP20 Basic Operator Panel

Overview



BOP20 Basic Operator Panel

Faults can be acknowledged, parameters set and diagnostics information read out (e.g. alarm and fault messages) using the BOP20 Basic Operator Panel that can be attached to any CU310-2 or CU320-2 Control Unit.

Design

The BOP20 Basic Operator Panel has a backlit two-line display area and 6 keys.

The integrated plug connector on the rear of the BOP20 Basic Operator Panel provides its power and establishes communication with the CU310-2 or CU320-2 Control Unit.

Selection and ordering data

Description	Article No.
BOP20 Basic Operator Panel	6SL3055-0AA00-4BA0

Integration



CU310-2 DP Control Unit with attached BOP20 Basic Operator Panel



CU320-2 DP Control Unit with attached BOP20 Basic Operator Panel

SINAMICS S120 Chassis Format Converter Units

System components

Supplementary system components > AOP30 Advanced Operator Panel

Overview



The AOP30 Advanced Operator Panel is an input/output device for converters of the SINAMICS series, preferably for cabinet installation.

It has the following characteristics:

- Graphical backlit LCD display for plain text display and a bar display of process variables
- LEDs for display of the operating states
- Help function describing causes of and remedies for faults and alarms
- Keypad for operational control of a drive
- Local/remote switchover for selecting the operating location (control priority assigned to operator panel or customer terminal block / communication channel)
- Numeric keypad for input of setpoint or parameter values
- Function keys for guided navigation in the menu
- Two-stage safety concept to protect against accidental or unauthorized changes to settings.
 - Operation of the drive from the operator panel can be disabled by the keyboard lock so that only parameter values and process variables can be displayed on the operator panel.
 - A password can be used to prevent the unauthorized modification of converter parameters.
- Front panel with degree of protection IP55

If the open-loop and closed-loop control of multiple power units (multi-motor drives) is performed by just one CU320-2 Control Unit, the parameters, alarms and faults of all connected devices can be shown on the display at the same time and processed. The AOP30 and SINAMICS drive communicate via the RS232 serial interface using the PPI protocol.

The AOP30 may be omitted if the drive is only operated via PROFIBUS, for example, and no local display is required on the cabinet. The AOP30 can then be used simply for commissioning purposes and to obtain diagnostic information, in which case, it is plugged into the RS232 interface on the CU320-2 Control Unit. In this case, an external 24 V power supply (max. current requirement 200 mA) is required.

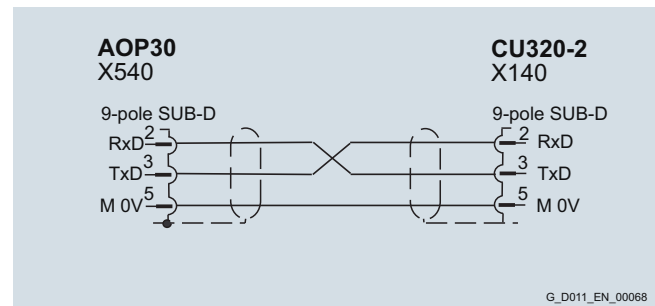

Assignment of the serial plug-in cable

Design

The AOP30 is an operator panel with graphical display and membrane keyboard. The device can be installed in a cabinet door which is between 2 mm and 4 mm thick.

Features:

- Display with green backlighting, resolution 240 × 64 pixels
- Membrane keyboard with 26 keys
- Connection for a 24 V power supply
- RS232 interface
- Time and date memory with internal battery backup
- 4 LEDs to indicate the operating state of the drive:
 - RUN green
 - ALARM yellow
 - FAULT red
 - Local/Remote green

Selection and ordering data

For the SINAMICS S120 Cabinet Modules, the AOP30 can be ordered as an option by specifying order code **K08**.

For the SINAMICS S150, the AOP30 Advanced Operator Panel is installed in the cabinet door as standard.

Description	Article No.
AOP30 Advanced Operator Panel	6SL3055-0AA00-4CA5
<i>Accessories</i>	
RS232 plug-in cable for connecting the AOP30 to the CU320-2	
1 m long	6FX8002-1AA01-1AB0
2 m long	6FX8002-1AA01-1AC0
3 m long	6FX8002-1AA01-1AD0
4 m long	6FX8002-1AA01-1AE0
5 m long	6FX8002-1AA01-1AF0
6 m long	6FX8002-1AA01-1AG0
7 m long	6FX8002-1AA01-1AH0
8 m long	6FX8002-1AA01-1AJ0
9 m long	6FX8002-1AA01-1AK0
10 m long	6FX8002-1AA01-1BA0

SINAMICS S120 Chassis Format Converter Units

System components

Supplementary system components > AOP30 Advanced Operator Panel

Function

The current operating states, setpoints and actual values, parameters, indices, faults and alarms are displayed on the display panel.

German, English, French, Italian, Spanish and Chinese are stored on the CU320-2 Control Unit CompactFlash card as operator panel languages. The desired language must be downloaded to the AOP30 prior to commissioning.

In addition to these preinstalled languages, **Russian** and **Portuguese** (Brazil) are also available for subsequent installation. Further languages are available on request.

Technical specifications

AOP30 Advanced Operator Panel 6SL3055-0AA00-4CA5	
Power supply	24 V DC (20.4 ... 28.8 V)
Current requirement	<ul style="list-style-type: none"> • Without backlighting <100 mA • For max. backlighting <200 mA
Data interface	RS232 interface, PPI protocol
Backup battery	3 V lithium CR2032
Operating temperature	0 ... 55 °C
Storage and transport temperature	-25 ... +70 °C
Degree of protection	IP20 for the inside of the cabinet IP55 for the outside of the cabinet
Dimensions	
• Width	212 mm
• Height	156 mm
• Depth	31 mm
Weight, approx.	0.55 kg

SINAMICS S120 Chassis Format Converter Units

System components

Supplementary system components > CBC10 Communication Board

Overview

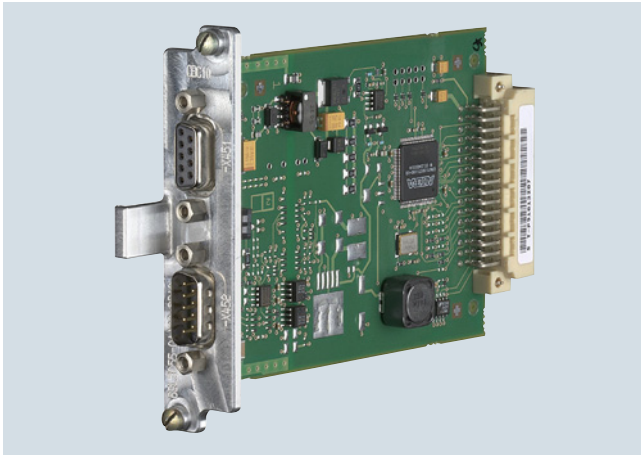

The CBC10 Communication Board is used to interface the CU320-2 Control Unit (and therefore the drive system) to the CAN (Controller Area Network) protocol. The board's driver software fulfils the standards of the following CANopen specification of the CiA organization (CAN in Automation):

- Communication profiles in accordance with DS 301
- Drive profile in accordance with DSP 402 (in this case Profile Velocity Mode)
- EDS (Electronic Data Sheet) in accordance with DSP 306
- Operational status signaling in accordance with DSP 305

Note:

The CAN address is set on the CU320-2 DP Control Unit by means of the two address switches. These address switches are not available on the CU320-2 PN Control Unit. In this case, the address can be set by means of parameters.

Design

The CBC10 Communication Board plugs into the option slot on the CU320-2 Control Unit. Two SUB-D connections for input and output are provided for the CAN interface on the CBC10 Communication Board.

Selection and ordering data

Description	Article No.
CBC10 Communication Board	6SL3055-0AA00-2CA0

Accessories

SUB-D connector 9-pin, female (3 units)	6FC9341-2AE
SUB-D connector 9-pin, male (3 units)	6FC9341-2AF

For the SINAMICS S150 and SINAMICS S120 Cabinet Modules, the CBC10 Communication Board can be ordered as an option by specifying order code **G20**.

Technical specifications

CBC10 Communication Board 6SL3055-0AA00-2CA0	
Power requirement, max. at 24 V DC via CU320-2 Control Unit	0.05 A
Power loss, max.	3 W
Weight, approx.	0.1 kg

SINAMICS S120 Chassis Format Converter Units

System components

Supplementary system components > CBE20 Communication Board

Overview

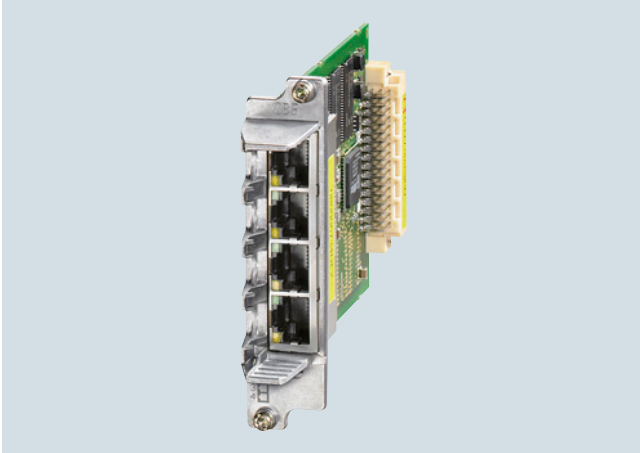

The CBE20 Communication Board is required

- if a SINAMICS S120 or SINAMICS S150 converter with a CU320-2 DP Control Unit (PROFIBUS) is to be connected to a PROFINET IO network
- SINAMICS Link is to be used to directly exchange data between several CU320-2 DP (PROFIBUS) or CU320-2 PN (PROFINET) Control Units without using a higher-level control system
- if EtherNet/IP support is required.

With the Communication Board CBE20, SINAMICS S120 and/or SINAMICS S150 is a PROFINET IO device in the sense of PROFINET and can perform the following functions:

- PROFINET IO device
- 100 Mbit/s full duplex
- Supports real-time classes of PROFINET IO:
 - RT (Real-Time)
 - IRT (Isochronous Real-Time), minimum send cycle 500 μ s
- Connection to control systems as PROFINET IO devices in accordance with PROFIdrive
- Standard TCP/IP communication for engineering processes using the STARTER commissioning tool
- Integrated 4-port switch with four RJ45 sockets based on the PROFINET ASIC ERTEC400. The optimum topology (line, star, tree) can therefore be configured without additional external switches

SINAMICS Link

SINAMICS Link can be used to directly exchange data between several CU320-2 DP (PROFIBUS) or CU320-2 PN (PROFINET) Control Units without using a higher-level control system. In this case, the CBE20 Communication Board is required. Possible applications for the SINAMICS Link include:

- Torque distribution for several drives
- Setpoint cascading for several drives
- Load distribution for drives coupled through a material web
- Couplings between SINAMICS G or SINAMICS S with the CU320-2 Control Unit and SINAMICS DC Master with CUD Control Units.

Participants other than the CU320-2 Control Units or the CUD Control Units of the SINAMICS DC Master cannot be integrated into this communication network.

SINAMICS Link is activated by appropriately parameterizing the Control Units of the nodes.

Selection and ordering data

Description	Article No.
CBE20 Communication Board	6SL3055-0AA00-2EB0

Accessories

Industrial Ethernet FC

• RJ45 Plug 180 (1 unit)	6GK1901-1BB10-2AA0
• RJ45 Plug 180 (10 units)	6GK1901-1BB10-2AB0
• Stripping tool	6GK1901-1GA00
• Standard cable GP 2x2	6XV1840-2AH10
• Flexible cable GP 2x2	6XV1870-2B
• Trailing cable GP 2x2	6XV1870-2D
• Trailing cable 2x2	6XV1840-3AH10
• Marine cable 2x2	6XV1840-4AH10

For further information about connectors and cables, refer to the Siemens Industry Mall:

www.siemens.com/industrymall

For the SINAMICS S150 and SINAMICS S120 Cabinet Modules, the CBE20 Communication Board can be ordered as an option by specifying order code **G33**.

Integration

The CBE20 Communication Board plugs into the option slot on the CU320-2 Control Unit.

Technical specifications

CBE20 Communication Board 6SL3055-0AA00-2EB0	
Current requirement at 24 V DC	0.16 A
Power loss	2.4 kW
Weight, approx.	0.1 kg
Approvals, according to	cULus

SINAMICS S120 Chassis Format Converter Units

System components

Supplementary system components > DMC20 DRIVE-CLiQ Hub Module

Overview



The DMC20 DRIVE-CLiQ Hub Module is used to implement a star-shaped topology of a DRIVE-CLiQ line. Two DMC20 DRIVE-CLiQ Hub Modules can be connected in series (cascaded).

Design

The DMC20 DRIVE-CLiQ Hub Module in degree of protection IP20 is designed for mounting in control cabinets.

The following are located on the DMC20 DRIVE-CLiQ Hub Module:

- 6 DRIVE-CLiQ sockets for connecting 5 DRIVE-CLiQ devices
- 1 connection for the electronics power supply via the 24 V DC supply connector

The status of the DMC20 DRIVE-CLiQ Hub Module is indicated via a multi-color LED.

Selection and ordering data

Description	Article No.
DMC20 DRIVE-CLiQ Hub Module Without DRIVE-CLiQ cable	6SL3055-0AA00-6AA1
<i>Accessories for re-ordering</i>	
Dust-proof blanking plugs (50 units) For DRIVE-CLiQ port	6SL3066-4CA00-0AA0

Technical specifications

DMC20 DRIVE-CLiQ Hub Module 6SL3055-0AA00-6AA1	
Power requirement, max. at 24 V DC without DRIVE-CLiQ supply	0.15 A
• Conductor cross-section, max.	2.5 mm ²
Degree of protection	IP20
Dimensions	
• Width	30 mm
• Height	151 mm
• Depth	110 mm
Weight, approx.	0.36 kg
Approvals, according to	cULus

SINAMICS S120 Chassis Format Converter Units

System components

Supplementary system components > DMC20 DRIVE-CLiQ Hub Module

Integration

Signals from more than one encoder can be collected with one DRIVE-CLiQ Hub Module and forwarded to the Control Unit through a single DRIVE-CLiQ cable.

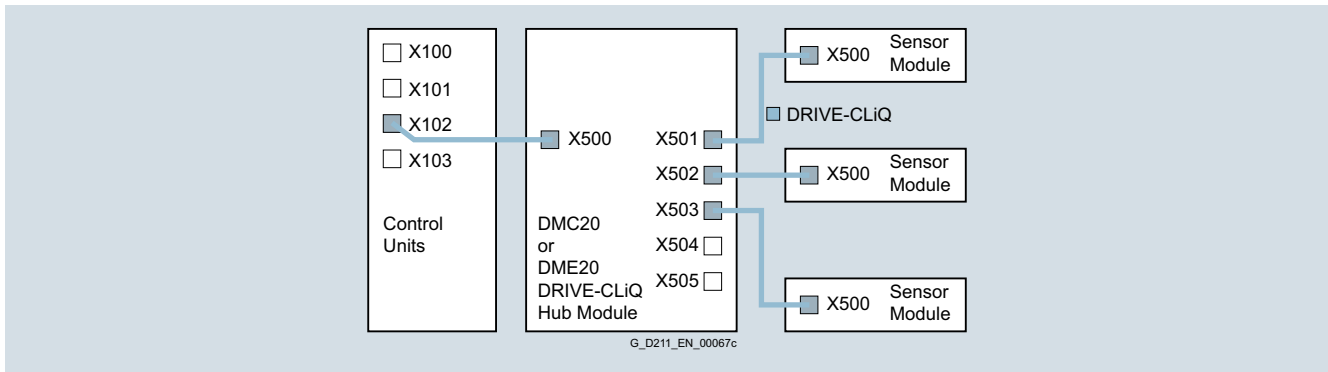

With a DRIVE-CLiQ Hub Module, individual DRIVE-CLiQ devices can be removed without interrupting the data exchange with the remaining devices in the DRIVE-CLiQ line.

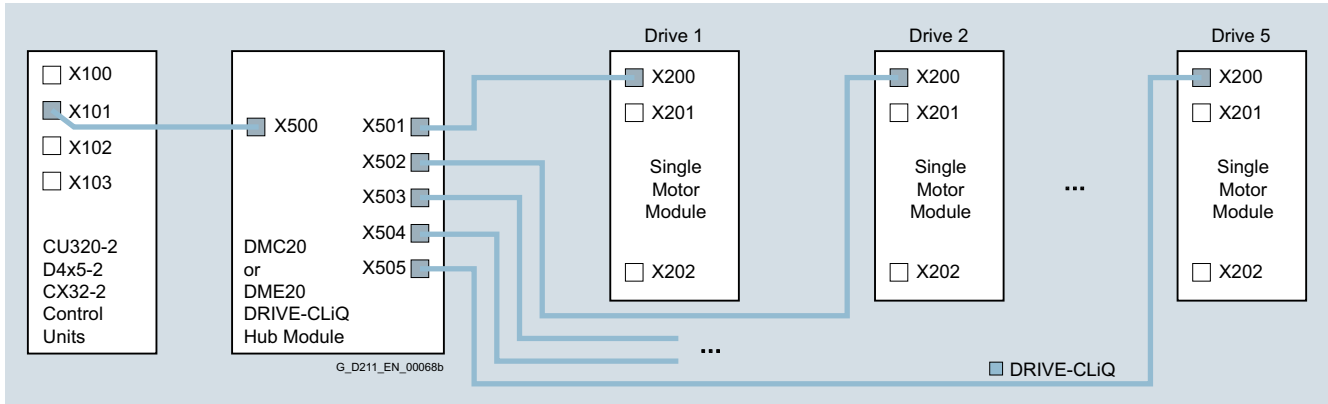

SINAMICS S120 Chassis Format Converter Units

System components

Supplementary system components > DME20 DRIVE-CLiQ Hub Module

Overview



The DME20 DRIVE-CLiQ Hub Module is used to implement a star-shaped topology of a DRIVE-CLiQ line. Two DME20 DRIVE-CLiQ Hub Modules can be connected in series (cascaded).

Design

The following are located on the DME20 DRIVE-CLiQ Hub Module:

- 6 DRIVE-CLiQ sockets for connecting 5 DRIVE-CLiQ devices
- 1 connection for the electronics power supply via the 24 V DC circular supply connector with conductor cross-section $4 \times 0.75 \text{ mm}^2$ (pins 1+2 internally bridged; pins 3+4 internally bridged)

The scope of supply of the DME20 DRIVE-CLiQ Hub Modules includes:

- 6 blanking plugs for sealing unused DRIVE-CLiQ sockets

Selection and ordering data

Description	Article No.
DME20 DRIVE-CLiQ Hub Module Without DRIVE-CLiQ cable; without electronics power supply cable and circular connector for 24 V DC	6SL3055-0AA00-6AB0
Accessories	
24 V DC power supply cable	
Ordering and delivery Phoenix Contact www.phoenixcontact.com	
<ul style="list-style-type: none"> • Shielded connector, 5-pole, can be assembled by the user 	Art. No. 1508365
<ul style="list-style-type: none"> • Unshielded connector, 4-pole, can be assembled by the user, Speedcon rapid interlock 	Art. No. 1521601
Accessories for re-ordering	
Dust-proof blanking plugs IP67 (6 units) For DRIVE-CLiQ port	6SL3066-4CA01-0AA0

Technical specifications

DME20 DRIVE-CLiQ Hub Module 6SL3055-0AA00-6AB0	
Power requirement, max. at 24 V DC without DRIVE-CLiQ supply	0.15 A
• Conductor cross-section, max.	$4 \times 0.75 \text{ mm}^2$
Degree of protection	IP67
Dimensions	
• Width	99 mm
• Height	149 mm
• Depth	55.7 mm (without connector)
Weight, approx.	0.8 kg
Approvals, according to	cULus

SINAMICS S120 Chassis Format Converter Units

System components

Supplementary system components > DME20 DRIVE-CLiQ Hub Module

Integration

Signals from more than one encoder can be collected with one DRIVE-CLiQ Hub Module and forwarded to the Control Unit through a single DRIVE-CLiQ cable.

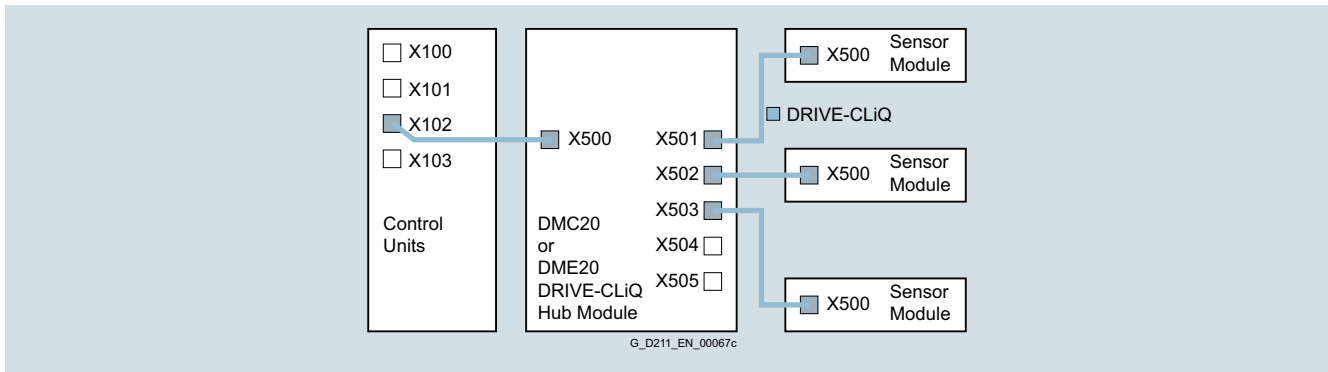

With a DRIVE-CLiQ Hub Module, individual DRIVE-CLiQ devices can be removed without interrupting the data exchange with the remaining devices in the DRIVE-CLiQ line.

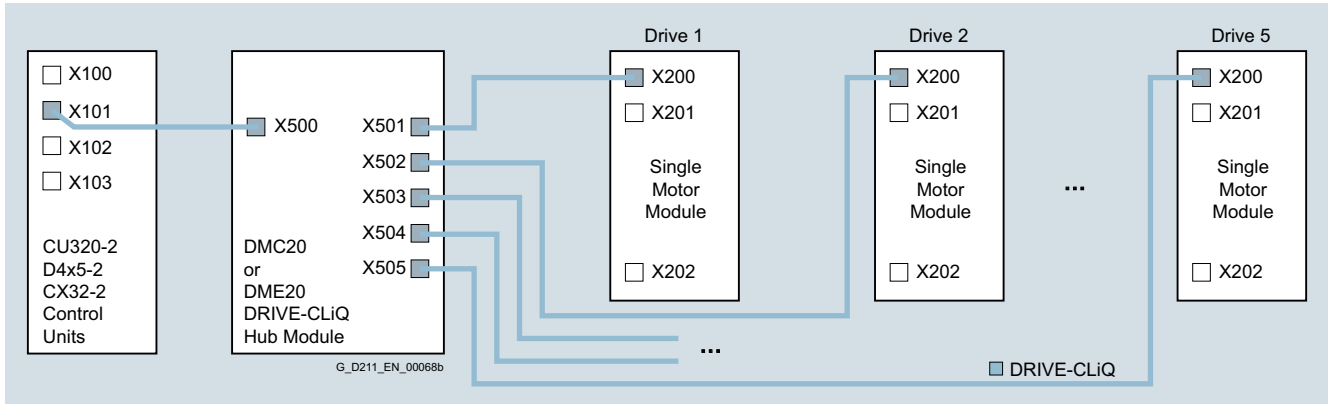

The DME20 DRIVE-CLiQ Hub Module in degree of protection IP67 is suitable for installation outside control cabinets.

SINAMICS S120 Chassis Format Converter Units

System components

Supplementary system components > TB30 Terminal Board

Overview

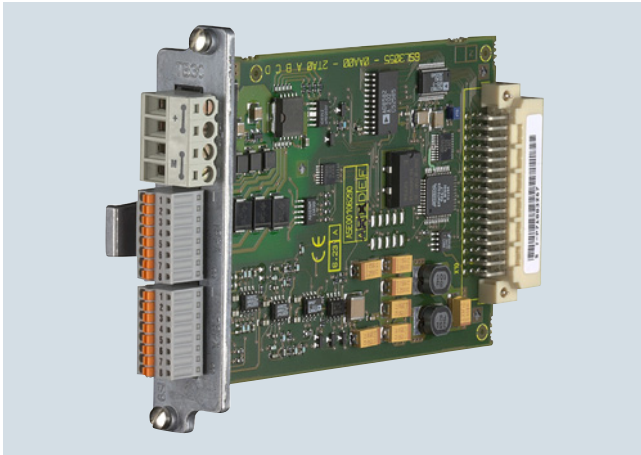

The TB30 Terminal Board supports the addition of digital inputs/digital outputs and analog inputs/analog outputs to a Control Unit.

Design

The following are located on the TB30 Terminal Board:

- Power supply for digital inputs/digital outputs
- 4 digital inputs
- 4 digital outputs
- 2 analog inputs
- 2 analog outputs

A shield connection for the signal cable shield is located on the Control Unit.

Selection and ordering data

Description	Article No.
TB30 Terminal Board	6SL3055-0AA00-2TA0

For SINAMICS S150, the TB30 Terminal Board can be ordered as an option by specifying order code **G62**.

Technical specifications

TB30 Terminal Board 6SL3055-0AA00-2TA0	
Power requirement, max. at 24 V DC via Control Unit CU320-2 without taking account of digital outputs	0.05 A
<ul style="list-style-type: none"> • Conductor cross-section, max. • Fuse protection, max. 	2.5 mm ² 20 A
Digital inputs In accordance with IEC 61131-2 Type 1	
<ul style="list-style-type: none"> • Voltage • Low level (an open digital input is interpreted as "low") • High level • Current consumption at 24 V DC, typ. • Delay time of digital inputs ¹⁾, approx. - L → H - H → L • Conductor cross-section, max. 	-3 ... +30 V -3 ... +5 V 15 ... 30 V 10 mA 50 μs 100 μs 0.5 mm ²
Digital outputs continuously short-circuit proof	
<ul style="list-style-type: none"> • Voltage • Load current per digital output, max. • Delay time of digital outputs ¹⁾, approx. • Conductor cross-section, max. 	24 V DC 500 mA 150 μs 0.5 mm ²
Analog inputs difference	
<ul style="list-style-type: none"> • Voltage range (an open analog input is interpreted as 0 V) • Internal resistance R_i • Resolution ²⁾ • Conductor cross-section, max. 	-10 ... +10 V 65 kΩ 13 bits + sign 0.5 mm ²
Analog outputs continuously short-circuit proof	
<ul style="list-style-type: none"> • Voltage range • Max. load current • Resolution • Settling time, approx. • Conductor cross-section, max. 	-10 ... +10 V -3 ... +3 mA 11 bits + sign 200 μs 0.5 mm ²
Power loss, max.	3 W
Weight, approx.	0.1 kg

¹⁾ The specified delay times refer to the hardware. The actual reaction time depends on the time slot in which the digital input/output is processed.

²⁾ If the analog input is to be operated in the signal processing sense with continuously variable input voltage, the sampling frequency $f_a = 1/t_{\text{time slice}}$ must be at least twice the value of the highest signal frequency f_{max} .

SINAMICS S120 Chassis Format Converter Units

System components

Supplementary system components > TB30 Terminal Board

Integration

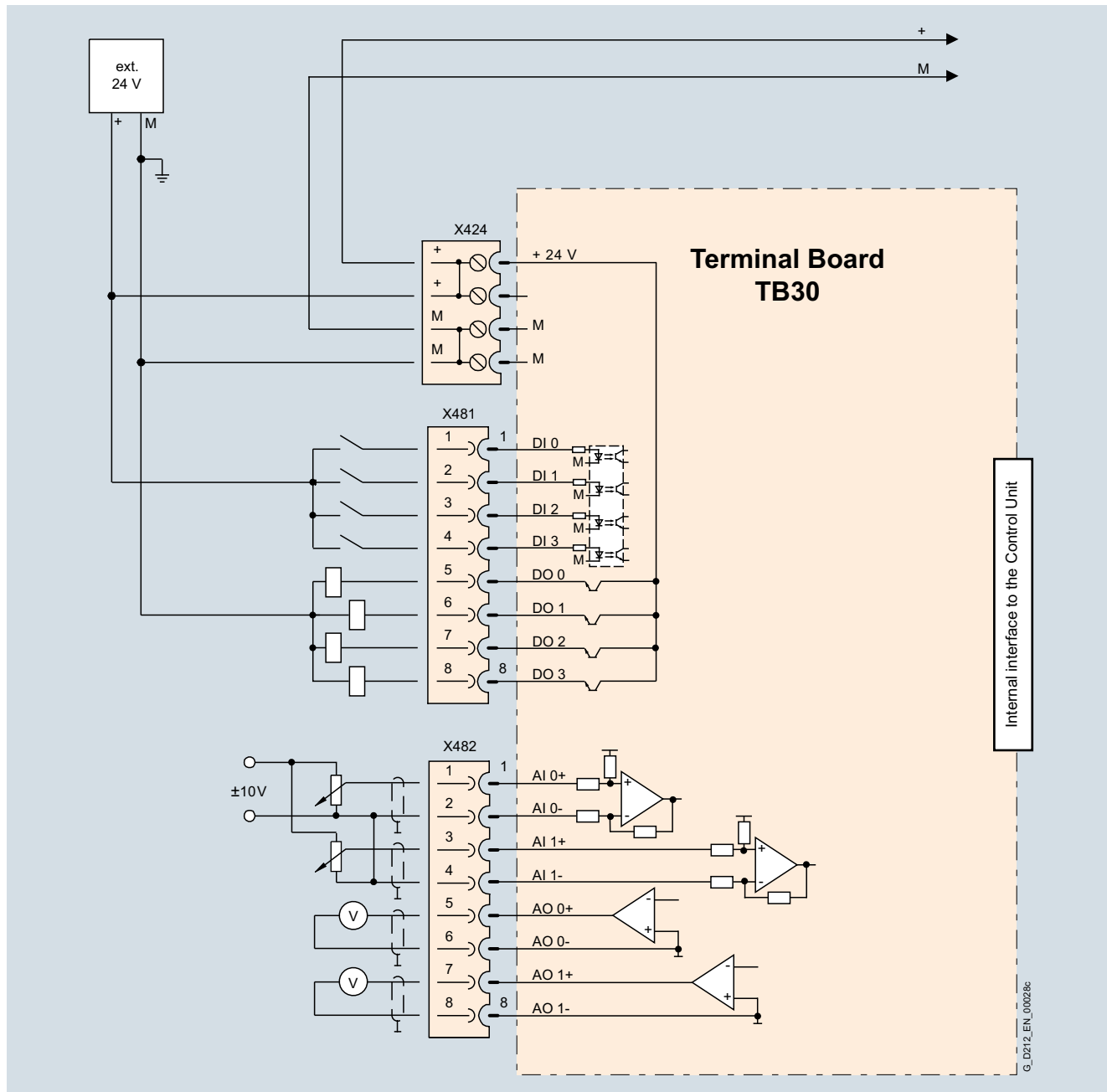

Connection example of a TB30 Terminal Board

SINAMICS S120 Chassis Format Converter Units

System components

Supplementary system components > TM15 Terminal Module

Overview



The number of available digital inputs and outputs within a drive system can be expanded with the TM15 Terminal Module.

Design

The TM15 Terminal Module is equipped with the following:

- 24 bidirectional digital inputs/outputs (electrical isolation in 3 groups with 8 channels per group)
- 24 green status LEDs for indicating the logical signal state of the corresponding terminal
- 2 DRIVE-CLiQ sockets
- 1 connection for the electronics power supply via the 24 V DC power supply connector
- 1 PE (protective earth) connection

The status of the TM15 Terminal Module is indicated via a multi-color LED.

The TM15 Terminal Module can be snapped onto a TH 35 standard mounting rail in accordance with EN 60715 (IEC 60715).

The signal cable shield can be connected to the TM15 Terminal Module by means of a shield connection terminal, e.g. Phoenix Contact type SK8 or Weidmüller type KLBÜ CO 1. The shield connection terminal must not be used as a strain relief mechanism.

Selection and ordering data

Description	Article No.
TM15 Terminal Module Without DRIVE-CLiQ cable	6SL3055-0AA00-3FA0
<i>Accessories</i>	
Dust-proof blanking plugs (50 units) For DRIVE-CLiQ port	6SL3066-4CA00-0AA0

Technical specifications

TM15 Terminal Module 6SL3055-0AA00-3FA0	
Power requirement, max. at 24 V DC without load	0.15 A
• Conductor cross-section, max.	2.5 mm ²
• Fuse protection, max.	20 A
Number of DRIVE-CLiQ sockets	2
I/O	
• Digital inputs/outputs	Parameterizable channel-by-channel as DI or DO
• Number of digital inputs/outputs	24
• Isolation	Yes, in groups of 8
• Cables and connections	Plug-in screw-type terminals
• Conductor cross-section, max.	1.5 mm ²
Digital inputs	
• Voltage	-30 ... +30 V
• Low level (an open digital input is interpreted as "low")	-30 ... +5 V
• High level	15 ... 30 V
• Current consumption at 24 V DC	5 ... 11 mA
• Delay times of digital inputs, typ. ¹⁾	
- L → H	50 μs
- H → L	100 μs
Digital outputs continuously short-circuit proof	
• Voltage	24 V DC
• Load current per digital output, max.	0.5 A
• Delay times (ohmic load) ¹⁾	
- L → H, typ.	50 μs
- L → H, max.	100 μs
- H → L, typ.	150 μs
- H → L, max.	225 μs
• Total current of outputs (per group), max.	
- To 60 °C	2 A
- To 50 °C	3 A
- To 40 °C	4 A
Power loss, max.	3 W
PE connection	M4 screw
Dimensions	
• Width	50 mm
• Height	150 mm
• Depth	111 mm
Weight, approx.	0.86 kg

¹⁾ The specified delay times refer to the hardware. The actual reaction time depends on the time slot in which the digital input/output is processed.

SINAMICS S120 Chassis Format Converter Units

System components

Supplementary system components > TM15 Terminal Module

Integration

The TM15 Terminal Module communicates with the CU310-2 or CU320-2 Control Unit via DRIVE-CLiQ.

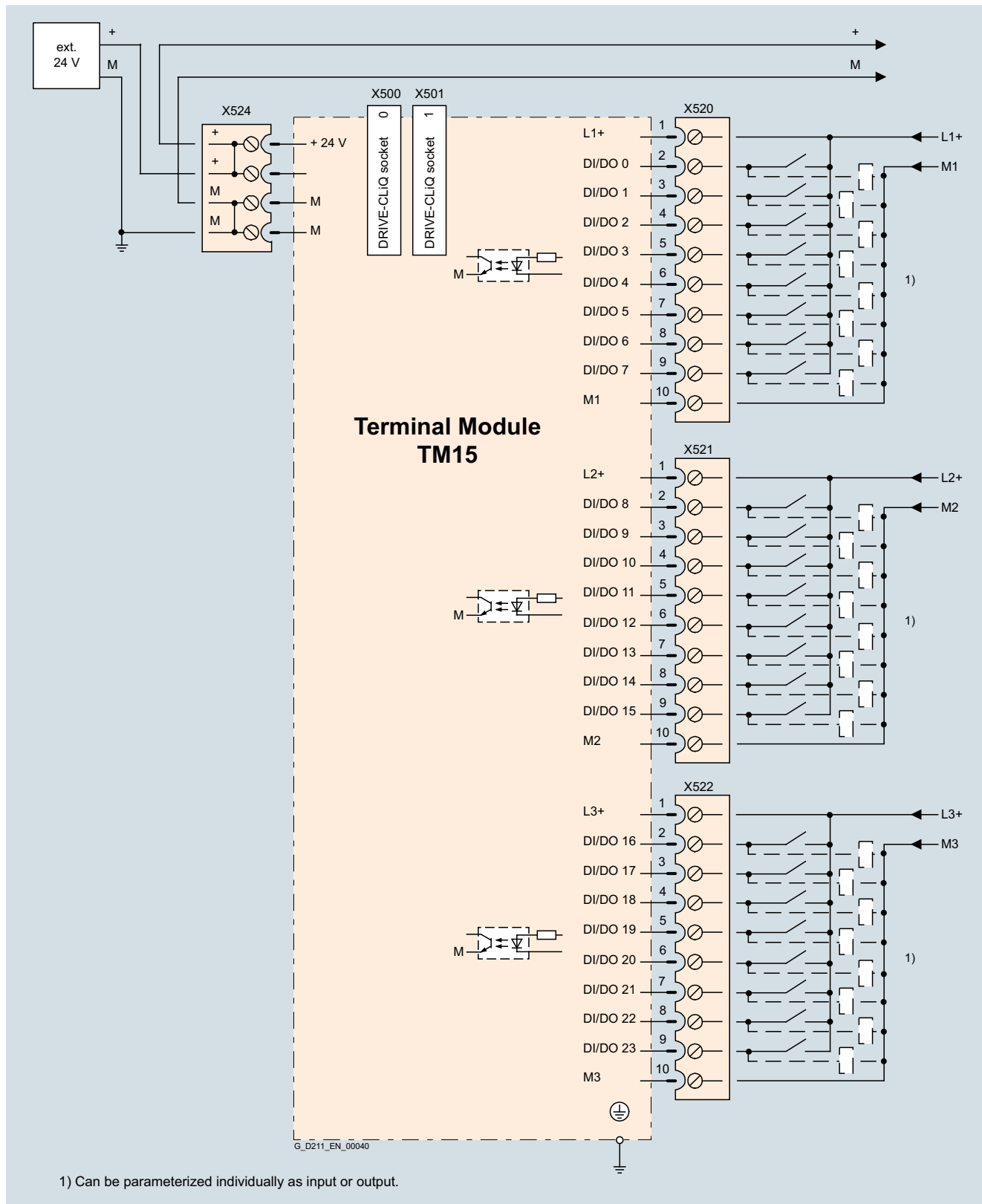

Connection example of TM15 Terminal Module

SINAMICS S120 Chassis Format Converter Units

System components

Supplementary system components > TM31 Terminal Module

Overview



With the TM31 Terminal Module, the number of available digital inputs and outputs and the number of analog input and outputs within a drive can be expanded.

The TM31 Terminal Module also features relay outputs with changeover contact and a temperature sensor input.

Design

The following are located on the TM31 Terminal Module:

- 8 digital inputs
- 4 bidirectional digital inputs/outputs
- 2 relay outputs with changeover contact
- 2 analog inputs
- 2 analog outputs
- 1 temperature sensor input (KTY84-130 or PTC)
- 2 DRIVE-CLiQ sockets
- 1 connection for the electronics power supply via the 24 V DC supply connector
- 1 PE/protective conductor connection

The TM31 Terminal Module can be snapped onto a TH 35 standard mounting rail in accordance with EN 60715 (IEC 60715).

The signal cable shield can be attached to the TM31 Terminal Module via a shield connection terminal, e.g. type SK8 supplied by Phoenix Contact or type KLBÜ CO 1 supplied by Weidmüller. The shield connection terminal must not be used as a strain relief mechanism.

The status of the TM31 Terminal Module is indicated via a multi-color LED.

Selection and ordering data

Description	Article No.
TM31 Terminal Module Without DRIVE-CLiQ cable	6SL3055-0AA00-3AA1
<i>Accessories</i>	
Dust-proof blanking plugs (50 units) For DRIVE-CLiQ port	6SL3066-4CA00-0AA0

For the SINAMICS S150 and SINAMICS S120 Cabinet Modules, the TM31 Terminal Module can be ordered as an option by specifying order code **G60** or **G61**.

Technical specifications

TM31 Terminal Module

6SL3055-0AA00-3AA1

Power requirement, max. At 24 V DC without taking account of the digital outputs and DRIVE-CLiQ supply	0.5 A
• Conductor cross-section, max.	2.5 mm ²
• Fuse protection, max.	20 A
Digital inputs In accordance with IEC 61131-2 Type 1	
• Voltage	-3 ... +30 V
• Low level (an open digital input is interpreted as "low")	-3 ... +5 V
• High level	15 ... 30 V
• Current consumption at 24 V DC, typ.	10 mA
• Delay times of digital inputs ¹⁾ , approx.	
- L → H	50 μs
- H → L	100 μs
• Conductor cross-section, max.	1.5 mm ²
Digital outputs continuously short-circuit proof	
• Voltage	24 V DC
• Load current per digital output, max.	100 mA
• Total current of digital outputs, max.	400 mA
• Delay times of digital outputs ¹⁾	
- Typ.	150 μs with 0.5 A resistive load
- Max.	500 μs
• Conductor cross-section, max.	1.5 mm ²
Analog inputs a switch is used to toggle between voltage and current input	
• As voltage input	
- Voltage range	-10 ... +10 V
- Internal resistance R_i	100 kΩ
- Resolution ²⁾	11 bits + sign
• As current input	
- Current ranges	4 ... 20 mA, -20 ... +20 mA, 0 ... 20 mA
- Internal resistance R_i	250 Ω
- Resolution ²⁾	10 bits + sign
• Conductor cross-section, max.	1.5 mm ²

TM31 Terminal Module

6SL3055-0AA00-3AA1

Analog outputs continuously short-circuit proof	
• Voltage range	-10 ... +10 V
• Max. load current	-3 ... +3 mA
• Current ranges	4 ... 20 mA, -20 ... +20 mA, 0 ... 20 mA
• Load resistance, max.	500 Ω for outputs in the range -20 ... +20 mA
• Resolution	11 bits + sign
• Conductor cross-section, max.	1.5 mm ²
Relay outputs CO contacts	
• Max. load current	8 A
• Operational voltage, max.	250 V AC, 30 V DC
• Switching capacity, max.	
- At 250 V AC	2000 VA (cos φ = 1) 750 VA (cos φ = 0.4)
- At 30 V DC	240 W (resistive load)
• Required minimum current	100 mA
• Conductor cross-section, max.	2.5 mm ²
Power loss, max.	10 W
PE connection	M4 screw
Dimensions	
• Width	50 mm
• Height	150 mm
• Depth	111 mm
Weight, approx.	0.87 kg

¹⁾ The specified delay times refer to the hardware. The actual reaction time depends on the time slot in which the digital input/output is processed.

²⁾ If the analog input is to be operated in the signal processing sense with continuously variable input voltage, the sampling frequency $f_a = 1/t_{\text{time slice}}$ must be at least twice the value of the highest signal frequency f_{max} .

SINAMICS S120 Chassis Format Converter Units

System components

Supplementary system components > TM31 Terminal Module

Integration

The TM31 Terminal Module communicates with the CU310-2 or CU320-2 Control Unit via DRIVE-CLiQ.

3

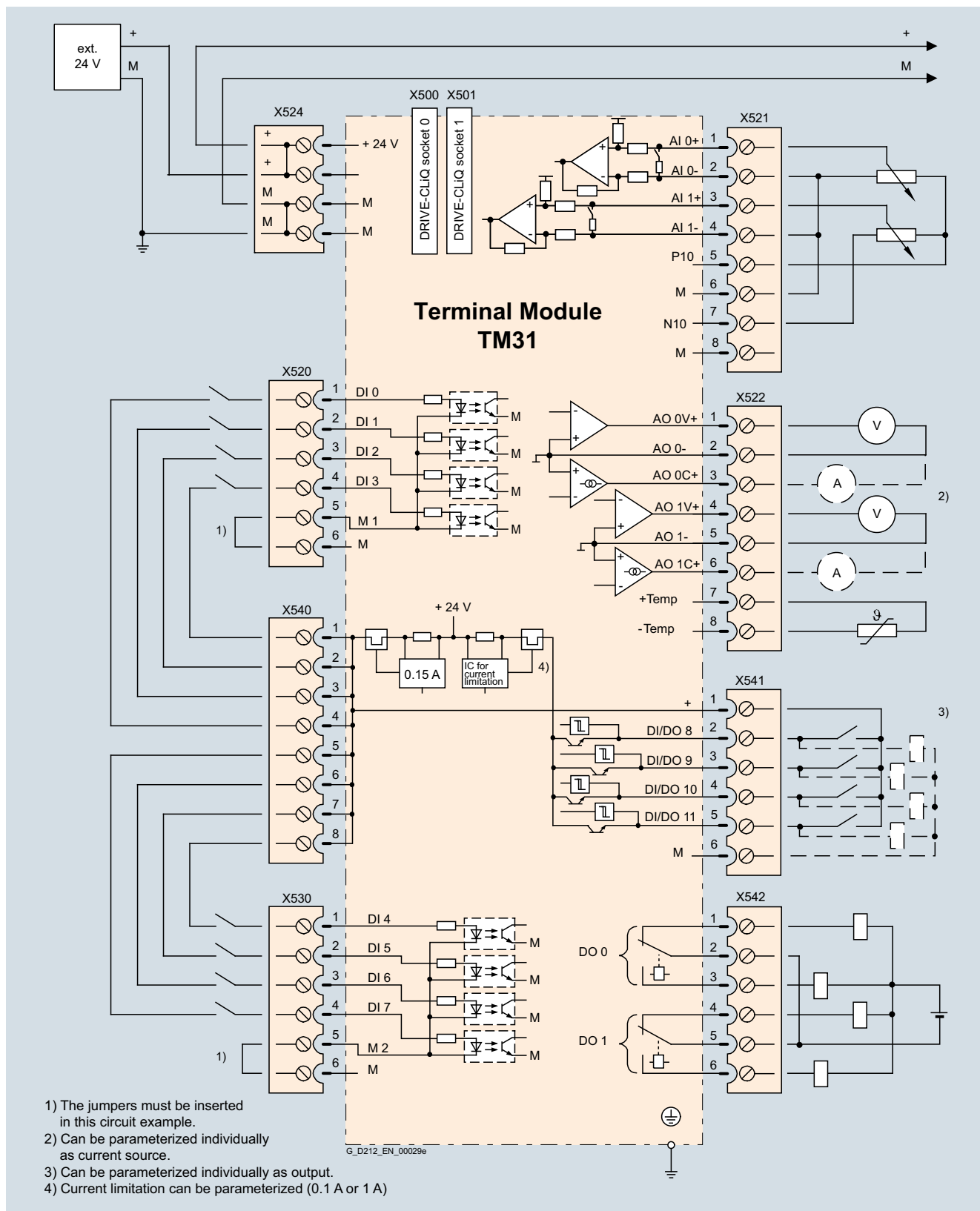

Connection example of TM31 Terminal Module

SINAMICS S120 Chassis Format Converter Units

System components

Supplementary system components > TM41 Terminal Module

Overview

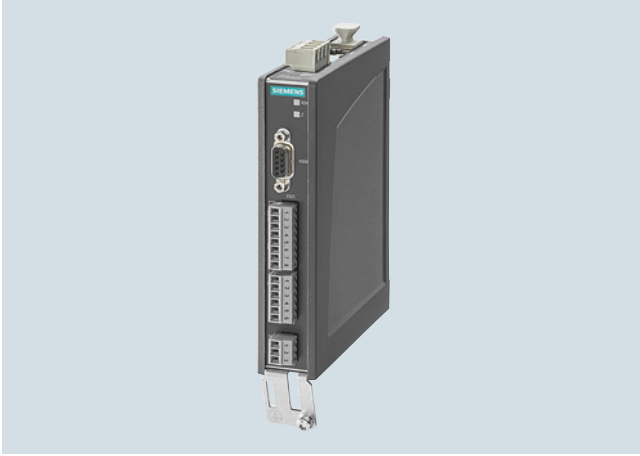

The TM41 Terminal Module supplies TTL signals which emulate an incremental encoder, e.g. to a higher-level control. The encoder interface (incremental encoder emulation) can be linked to an encoder signal from the Control Unit, e.g. incremental encoder sin/cos, by parameter assignment.

The TM41 Terminal Module increases the number of digital inputs/outputs and analog inputs that are available in the drive system.

Design

The following are located on the TM41 Terminal Module:

- 4 bidirectional digital inputs/outputs
- 4 digital inputs (with electrical isolation)
- 1 analog input
- 1 interface for emulation of TTL incremental encoder (RS422)
- 1 LED for signaling zero mark detection for encoder interface
- 2 DRIVE-CLiQ sockets
- 1 connection for the 24 V DC supply of the digital outputs
- 1 connection for the electronics power supply via the 24 V DC supply connector
- 1 PE/protective conductor connection

The TM41 Terminal Module can be snapped onto a TH 35 standard mounting rail in accordance with EN 60715 (IEC 60715).

The signal cable shield can be connected to the TM41 Terminal Module via a shield connection terminal, e.g. type SK8 supplied by Phoenix Contact or type KLBÜ CO 1 supplied by Weidmüller. The shield connection terminal must not be used for strain relief.

The status of the TM41 Terminal Module is indicated via a multi-color LED.

An LED next to the interface for TTL pulse encoder emulation is illuminated as soon as a zero mark is detected.

Selection and ordering data

Description	Article No.
TM41 Terminal Module Without DRIVE-CLiQ cable	6SL3055-0AA00-3PA1
<i>Accessories</i>	
Dust-proof blanking plugs (50 units) For DRIVE-CLiQ port	6SL3066-4CA00-0AA0

SINAMICS S120 Chassis Format Converter Units

System components

Supplementary system components > TM41 Terminal Module

Technical specifications

TM41 Terminal Module 6SL3055-0AA00-3PA1	
Current requirement (X524 at 24 V DC) without DRIVE-CLiQ supply or digital outputs (X514)	0.5 A
• Conductor cross-section, max.	2.5 mm ²
• Fuse protection, max.	20 A
I/O	
• Digital inputs/outputs	Individually parameterizable as DI or DO
• Number of digital inputs/outputs	4
• Number of digital input/outputs (with isolation)	4
• Cables and connections	Plug-in screw-type terminals
• Conductor cross-section, max.	1.5 mm ²
Digital inputs	
• Voltage	
- Without electrical isolation	-3 ... +30 V
- With electrical isolation	-30 ... +30 V
• Low level (an open digital input is interpreted as "low")	
- Without electrical isolation	-3 ... +5 V
- With electrical isolation	-30 ... +5 V
• High level	15 ... 30 V
• Current consumption at 24 V DC, typ.	<9 mA
• Delay times of digital inputs, max. ¹⁾	
- L → H	3 ms
- H → L	3 ms
Digital outputs continuously short-circuit proof	
• Voltage	24 V DC
• Load current per digital output, max.	0.5 A
• Delay times (resistive load) ¹⁾	
- L → H, typ.	50 μs
- L → H, max.	100 μs
- H → L, typ.	75 μs
- H → L, max.	150 μs
Analog input difference	
• Voltage range	-10 ... +10 V
• Internal resistance	≥100 kΩ
• Resolution ²⁾	12 bits + sign

TM41 Terminal Module 6SL3055-0AA00-3PA1	
Pulse encoder emulation	
• Level	TTL (RS422), A+, A-, B+, B-, zero track N+, N-
• Limit frequency f_{max} .	512 kHz
• Ratio Encoder pulses : Encoder emulation	Any number of ratio/ reduction ratio of pulses
Power loss, max.	12 W
PE connection	M4 screw
Dimensions	
• Width	30 mm
• Height	151 mm
• Depth	110 mm
Weight, approx.	0.32 kg

¹⁾ The specified delay times refer to the hardware. The actual reaction time depends on the time slot in which the digital input/output is processed.

²⁾ If the analog input is to be operated in the signal processing sense with continuously variable input voltage, the sampling frequency $f_a = 1/t_{\text{time slice}}$ must be at least twice the value of the highest signal frequency f_{max} .

SINAMICS S120 Chassis Format Converter Units

System components

Supplementary system components > TM41 Terminal Module

Integration

The TM41 Terminal Module communicates with the CU310-2 or CU320-2 Control Unit via DRIVE-CLiQ.

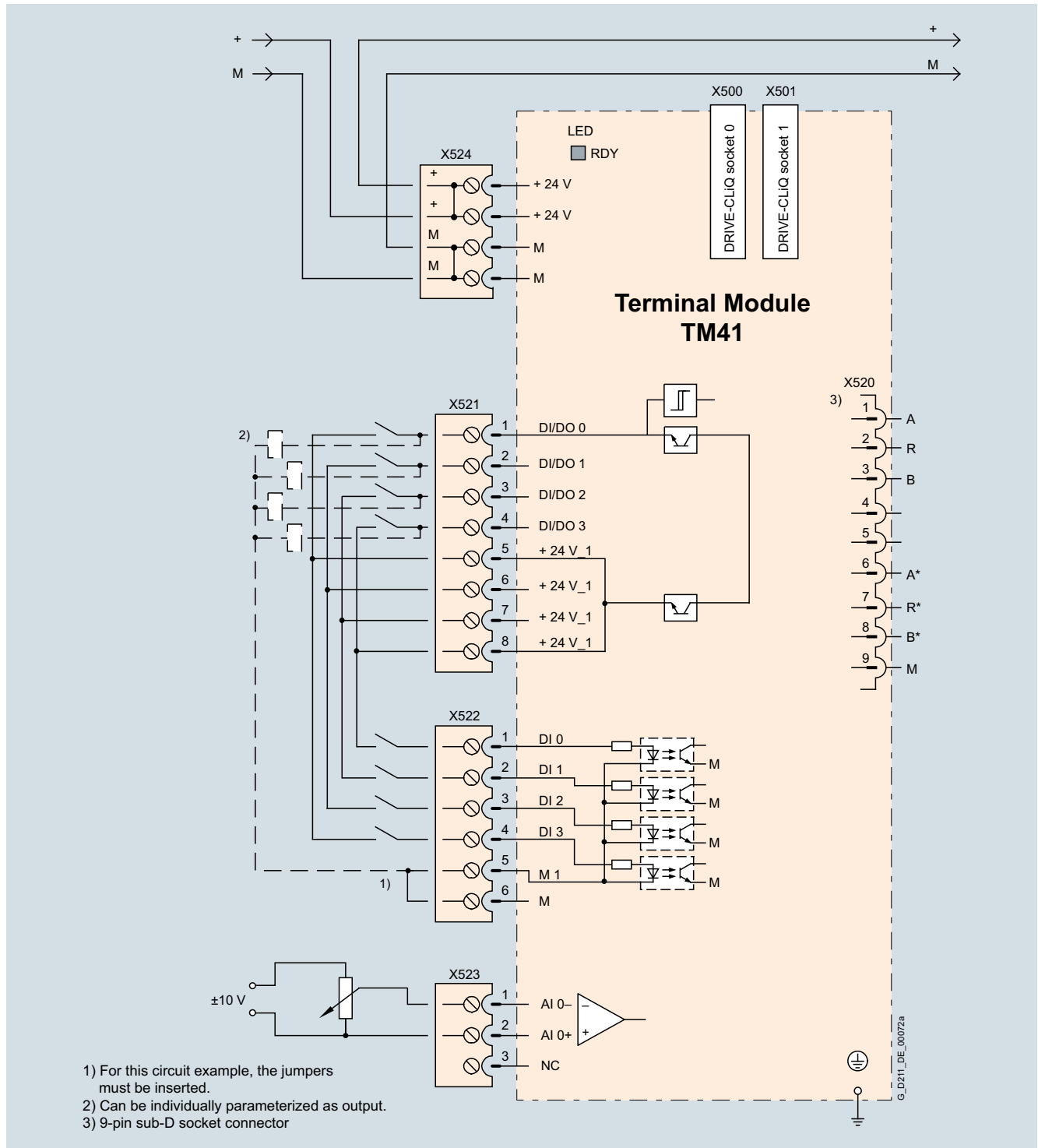

Connection example of TM41 Terminal Module

3

SINAMICS S120 Chassis Format Converter Units

System components

Supplementary system components > TM54F Terminal Module

Overview



The TM54F Terminal Module is a dual-processor I/O interface with four fail-safe digital outputs and ten fail-safe digital inputs for utilization of the Safety Integrated functions of the SINAMICS S120 drive system via external actuators and sensors.

Every available safety function integrated in the drive can be controlled via the fail-safe digital inputs on the TM54F Terminal Module. In the event that the parameterized safety functions of several drives operated together on a Control Unit are to be executed together, then these drives can be grouped in the TM54F Terminal Module. The advantage of this approach is that only one fail-safe digital input needs to be connected for these drives.

The fail-safe digital inputs and outputs have two channels and are redundantly configured with an internal data cross-check using the two processors. A fail-safe digital output consists of one P-switching and one M-switching output as well as one digital input to read back the switching state. A fail-safe digital input consists of two digital inputs.

Safety sensors can be connected over two switchable 24 V sensor supplies and can be evaluated over the fail-safe digital inputs. The switchable 24 V sensor supply ensures that the fail-safe digital inputs can be dynamized to detect dormant errors (this dynamization is used to check the shutdown paths). An unswitchable 24 V sensor supply is additionally provided by the TM54F Terminal Module for connecting undynamizable safety sensors.

The TM54F Terminal Module must be directly connected to a Control Unit via a DRIVE-CLiQ cable. Only one TM54F Terminal Module can be assigned to each Control Unit. It is not permissible to make the TM54F connection via another DRIVE-CLiQ device, e.g. a Motor Module or a Line Module.

Design

The following are located on the TM54F Terminal Module:

- 4 fail-safe digital outputs
- 10 fail-safe digital inputs
- 4 LEDs, single color for indicating the status of the read back channel of the fail-safe digital outputs
- 4 LEDs, dual-color for indicating the status of the fail-safe digital outputs
- 20 LEDs, dual-color for indicating the status of the fail-safe digital inputs
- 3 LEDs, single color for indicating the status of the 24 V sensor supplies
- 2 DRIVE-CLiQ sockets
- 2 connections for 24 V sensor supply, switchable
- 1 connection for 24 V sensor supply, not switchable
- 1 connection for the electronics power supply via the 24 V DC power supply connector
- 1 connection for the 24 V power supply to digital outputs and sensors
- 1 PE (protective earth) connection

The TM54F Terminal Module can be snapped onto a TH 35 standard mounting rail in accordance with EN 60715 (IEC 60715).

The signal cable shield can be attached to the TM54F Terminal Module via a shield connection terminal, e.g. type SK8 supplied by Phoenix Contact or type KLBÜ CO 1 supplied by Weidmüller. The shield connection terminal must not be used as a strain relief mechanism.

The status of the TM54F Terminal Module is indicated via a multi-color LED.

Pins for connector coding are included in the TM54F Terminal Module scope of supply.

Selection and ordering data

Description	Article No.
TM54F Terminal Module Without DRIVE-CLiQ cable	6SL3055-0AA00-3BA0
<i>Accessories</i>	
Dust-proof blanking plugs (50 units) For DRIVE-CLiQ port	6SL3066-4CA00-0AA0

For the SINAMICS S150 and SINAMICS S120 Cabinet Modules, the TM54F Terminal Module can be ordered as an option by specifying order code **K87**.

Technical specifications

TM54F Terminal Module 6SL3055-0AA00-3BA0	
Current requirement (X524 at 24 V DC) without DRIVE-CLiQ supply	0.2 A
• Conductor cross-section, max.	2.5 mm ²
• Fuse protection, max.	20 A
Max. current requirement ext. 24 V for supplying the digital outputs and 24 V sensor supply (X514 at 24 V DC)	4 A
• Conductor cross-section, max.	2.5 mm ²
• Fuse protection, max.	20 A
I/O	
• Number of fail-safe digital inputs	10
• Number of fail-safe digital outputs	4
• 24 V sensor supply	3, of which 2 can be temporarily shut down using an internal test routine for dynamizing fail-safe digital inputs, current carrying capacity 0.5 A each
• Cables and connections	Plug-in screw-type terminals
• Conductor cross-section, max.	1.5 mm ²
Digital inputs in accordance with IEC 61131-2 Type 1, with galvanic isolation	
• Voltage	-3 ... +30 V
• Low level (an open digital input is interpreted as "low")	-3 ... +5 V
• High level	15 ... 30 V
• Current consumption at 24 V DC, typ.	> 2 mA
• Delay time of digital inputs, approx. ¹⁾	
- L → H, typ.	30 μs
- H → L, typ.	60 μs
• Safe state	Low level (for inputs that can be inverted: without inversion)
Digital outputs continuously short-circuit proof	
• Voltage	24 V DC
• Load current per fail-safe digital output, max. ²⁾	0.5 A
• Delay times (resistive load) ¹⁾	
- L → H, typ.	300 μs
- H → L, typ.	350 μs
• Safe state	Output switched off

TM54F Terminal Module 6SL3055-0AA00-3BA0	
Scanning cycle t_{SI} for fail-safe digital inputs or fail-safe digital outputs	4 ... 25 ms (adjustable)
Power loss, max. At 24 V	4.5 W
PE connection	M4 screw
Dimensions	
• Width	50 mm
• Height	150 mm
• Depth	111 mm
Weight, approx.	0.9 kg
Safety Integrated	Acc. to IEC 61508 SIL 2 and EN ISO 13849-1 PLd and Category 3

¹⁾ The specified delay times refer to the hardware. The actual reaction time depends on the time slot in which the digital input/output is processed.

²⁾ The total current of all fail-safe digital outputs must not exceed 5.33 A.

SINAMICS S120 Chassis Format Converter Units

System components

Supplementary system components > TM54F Terminal Module

Integration

The TM54F Terminal Module communicates with the CU310-2 or CU320-2 Control Unit via DRIVE-CLIQ.

3

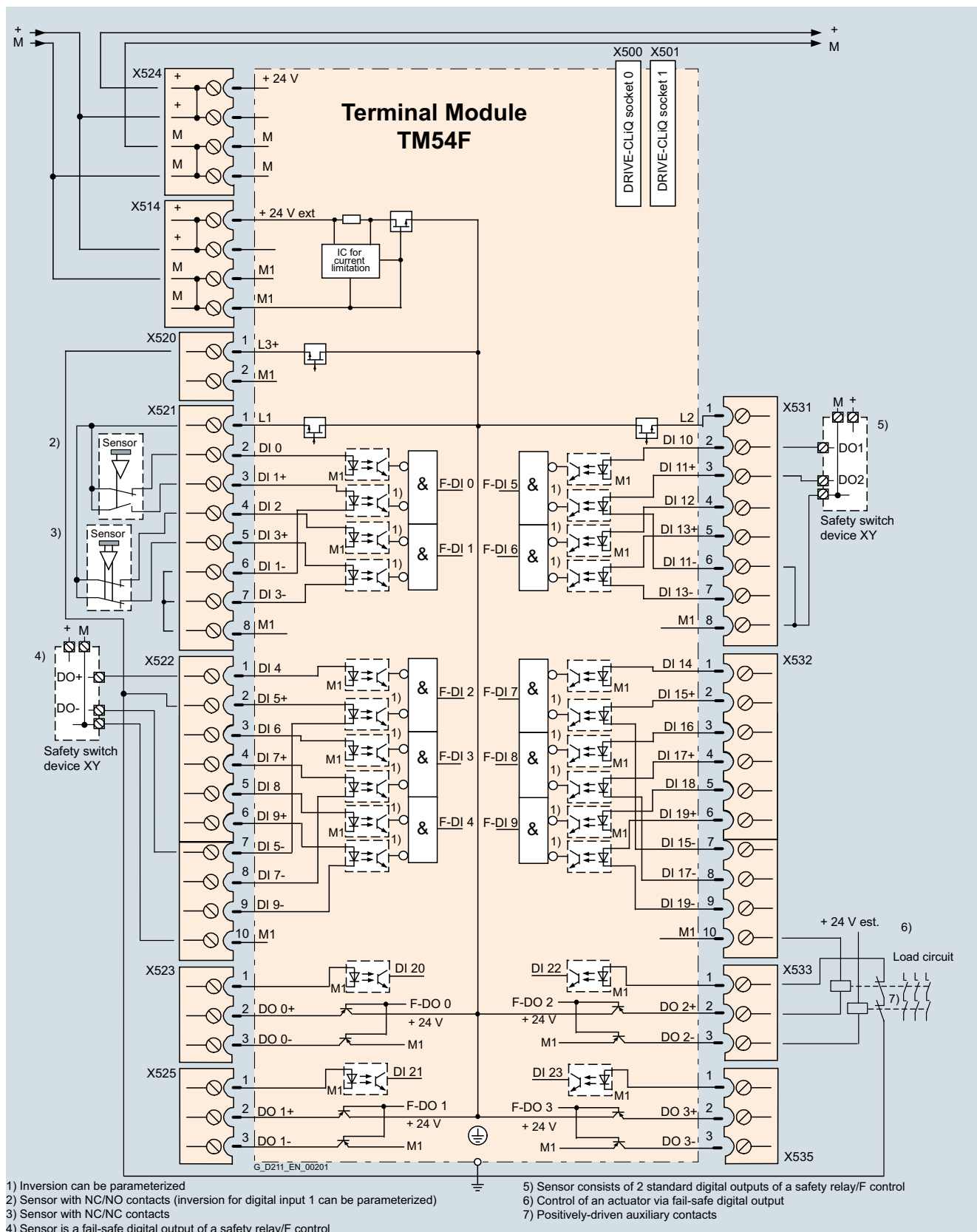

Connection example of TM54F Terminal Module

SINAMICS S120 Chassis Format Converter Units

System components

Supplementary system components > TM120 Terminal Module

Overview



Four temperature sensors (KTY84-130 or PTC) can be evaluated via the TM120 Terminal Module. The temperature sensor inputs are safely electrically separated from the evaluation electronics in the TM120 Terminal Module and are suitable for evaluating the temperature of special motors, e.g. 1FN linear motors and 1FW6 built-in torque motors.

Design

The following are located on the TM120 Terminal Module:

- 4 temperature sensor inputs (KTY84-130 or PTC)
- 2 DRIVE-CLiQ sockets
- 1 connection for the electronics power supply via the 24 V DC supply connector
- 1 PE/protective conductor connection

The status of the TM120 Terminal Module is indicated via a multi-color LED.

The TM120 Terminal Module can be snapped onto a TH 35 standard mounting rail in accordance with EN 60715 (IEC 60715).

Selection and ordering data

Description	Article No.
TM120 Terminal Module Without DRIVE-CLiQ cable	6SL3055-0AA00-3KA0
Accessories	
Dust-proof blanking plugs (50 units) For DRIVE-CLiQ port	6SL3066-4CA00-0AA0

Technical specifications

TM120 Terminal Module 6SL3055-0AA00-3KA0	
Power requirement, max. at 24 V DC	0.5 A
• Conductor cross-section, max.	2.5 mm ²
• Fuse protection, max.	20 A
Temperature sensor inputs The inputs can be individually parameterized to evaluate sensors of type KTY84-130 or PTC, or temperature switches	
• Conductor cross-section	0.2 ... 6 mm ²
• Constant current per sensor, approx.	2 mA
• Safe electrical separation up to line voltage, max.	480 V AC
Power loss, typically	2.4 W
PE connection	M4 screw
Dimensions	
• Width	30 mm
• Height	150 mm
• Depth	111 mm
Weight, approx.	0.41 kg

SINAMICS S120 Chassis Format Converter Units

System components

Supplementary system components > TM120 Terminal Module

Integration

The TM120 Terminal Module communicates with the CU310-2 or CU320-2 Control Unit via DRIVE-CLiQ.

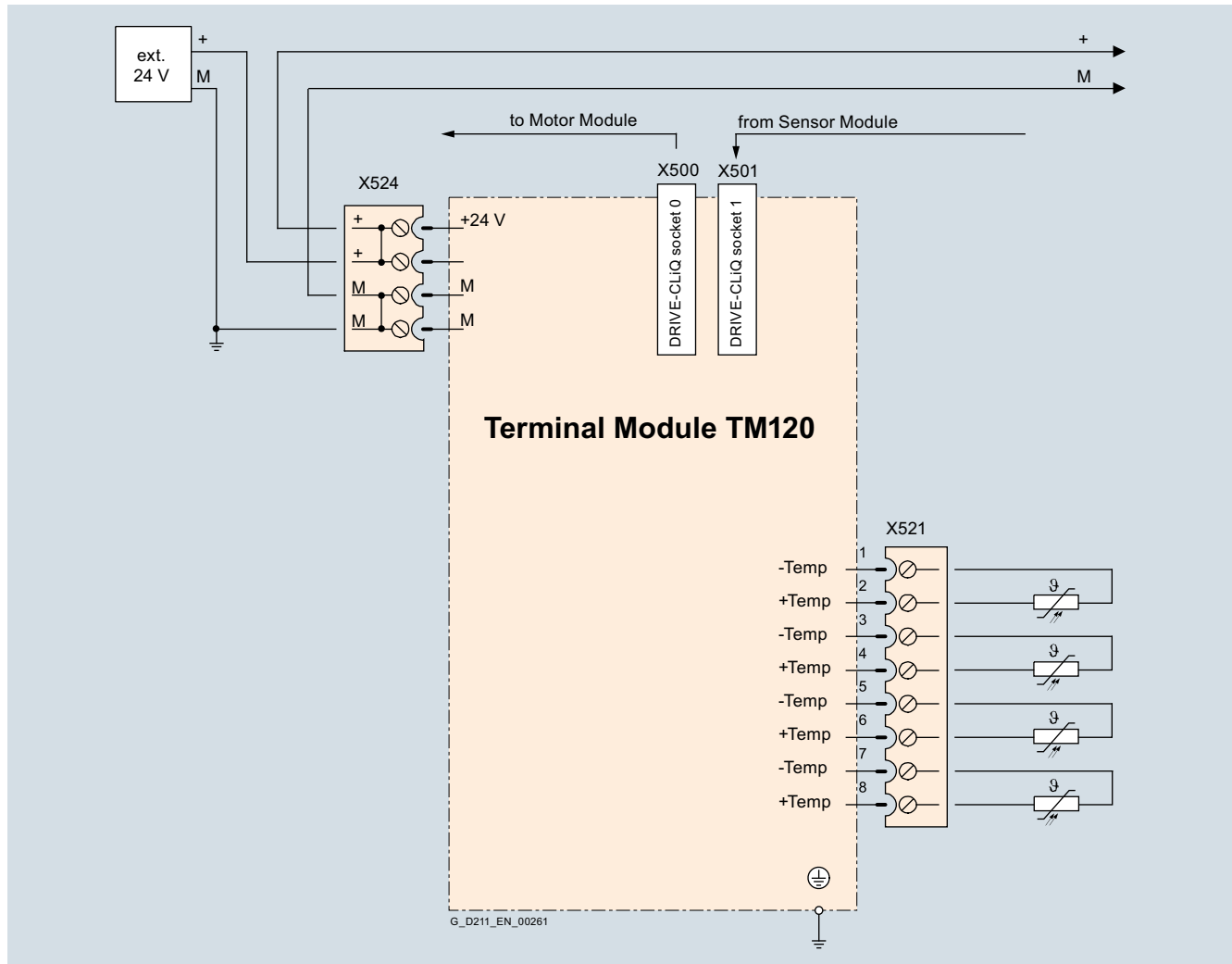

Connection example of TM120 Terminal Module

SINAMICS S120 Chassis Format Converter Units

System components

Supplementary system components > TM150 Terminal Module

Overview



The TM150 Terminal Module is a DRIVE-CLiQ component for temperature evaluation. The temperature is measured in a temperature range from -99 °C to +250 °C for the following temperature sensors:

- Pt100 (with monitoring for open-circuit and short-circuit)
- Pt1000 (with monitoring for open-circuit and short-circuit)
- KTY84 (with monitoring for open-circuit and short-circuit)
- PTC (with short-circuit monitoring)
- Bimetallic NC contact (without monitoring)

For the temperature sensor inputs, for each terminal block the evaluation can be parameterized for 1×2-wire, 2×2-wire, 3-wire or 4-wire. There is no galvanic isolation in the TM150 Terminal Module.

The temperature channels of a TM150 can be subdivided into 3 groups and evaluated together.

Design

The following are located on the TM150 Terminal Module:

- 6 ... 12 temperature sensor inputs
- 2 DRIVE-CLiQ sockets

The status of the TM150 Terminal Module is indicated via a multi-color LED.

The TM150 Terminal Module can be snapped onto a TH 35 standard mounting rail in accordance with EN 60715 (IEC 60715).

Selection and ordering data

Description	Article No.
TM150 Terminal Module Without DRIVE-CLiQ cable	6SL3055-0AA00-3LA0
Accessories	
Dust-proof blanking plugs (50 units) For DRIVE-CLiQ port	6SL3066-4CA00-0AA0

For the SINAMICS S150 and SINAMICS S120 Cabinet Modules, the TM150 Terminal Module can be ordered as an option by specifying order code **G51** or **G51** to **G54**.

Technical specifications

TM150 Terminal Module 6SL3055-0AA00-3LA0	
Power requirement, max. at 24 V DC	0.5 A
• Conductor cross section, max.	2.5 mm ²
• Fuse protection, max.	20 A
Temperature sensor inputs	
The inputs can be parameterized individually for the evaluation of sensors	
• Conductor cross section, max.	1.5 mm ²
• Measuring current per sensor, approx.	0.8 mA
Power loss	1.6 W
PE connection	M4 screw
Dimensions	
• Width	30 mm
• Height	150 mm
• Depth	119 mm
Weight, approx.	0.41 kg

SINAMICS S120 Chassis Format Converter Units

System components

Supplementary system components > TM150 Terminal Module

Integration

The TM150 Terminal Module communicates with the CU310-2 or CU320-2 Control Unit via DRIVE-CLiQ.

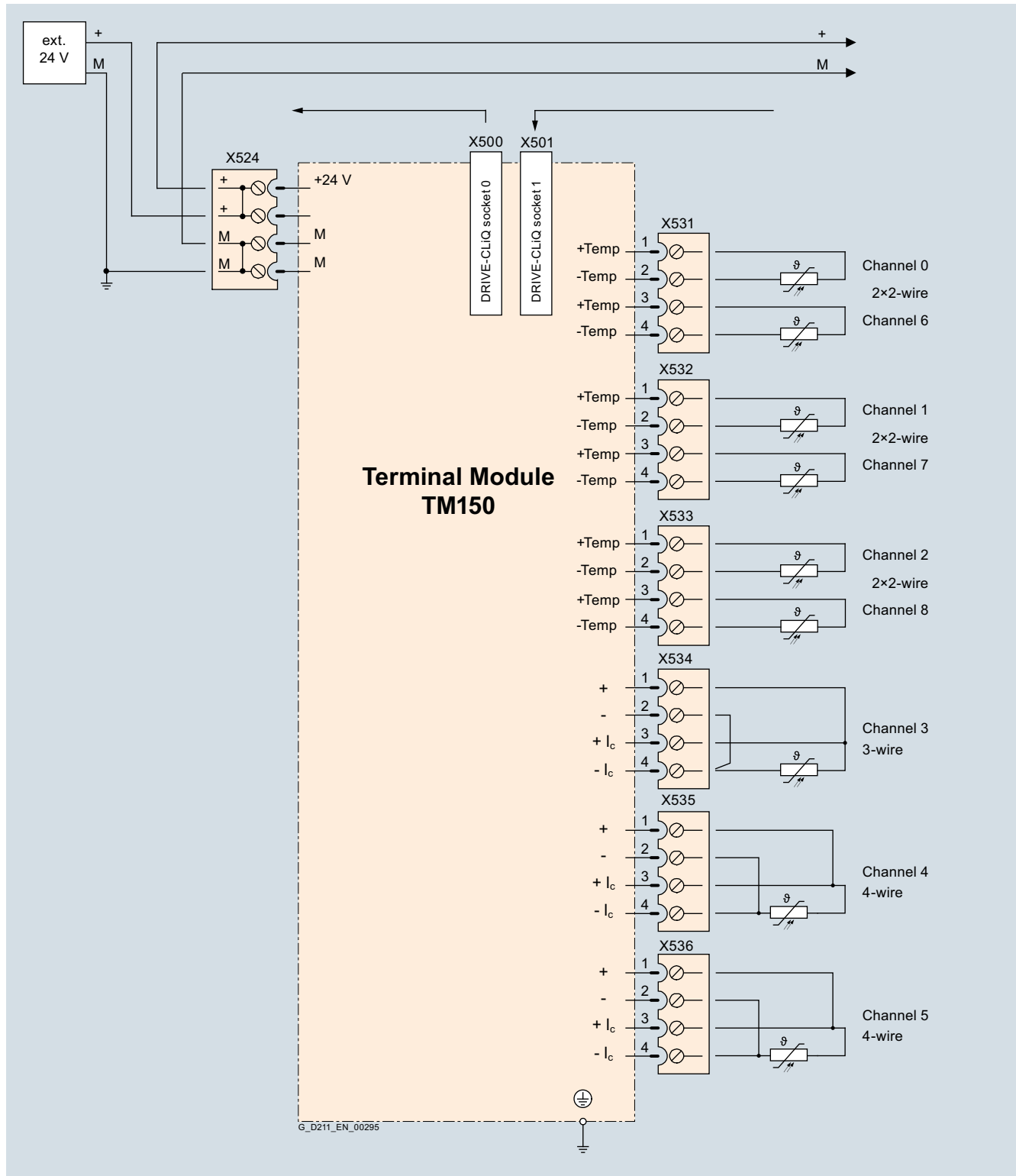

Connection example of a TM150 Terminal Module

SINAMICS S120 Chassis Format Converter Units

System components

Supplementary system components > VSM10 Voltage Sensing Module

Overview



The VSM10 Voltage Sensing Module enables the line or motor voltage characteristic to be measured precisely. The phase differential voltage can be measured, either grounded (in the delivery state with jumper plugged in) or isolated. The VSM10 Voltage Sensing Module is integrated in Active Interface Modules in chassis format and Smart Line Modules in chassis format.

In addition, the VSM10 is used to connect to rotating synchronous motors – or for a "quick flying restart" of rotating induction motors.

Design

The VSM10 Voltage Sensing Module has the following connections and interfaces:

- 1 connection for direct voltage sensing up to 690 V
- 1 connection for voltage sensing using voltage transformers, max. 100 V
- 2 analog inputs (reserved for monitoring of resonance in the Active Interface Module in chassis format)
- 1 temperature sensor input (KTY84-130 or PTC)
- 1 DRIVE-CLiQ socket
- 1 connection for the electronics power supply via the 24 V DC supply connector
- 1 plug-in jumper for either grounded (delivery state) or isolated measurement
- 1 PE/protective conductor connection

The VSM10 Voltage Sensing Module can be snapped onto a TH 35 standard mounting rail in accordance with EN 60715 (IEC 60715).

The status of the VSM10 Voltage Sensing Modules is indicated via a dual-color LED.

Selection and ordering data

Description	Article No.
VSM10 Voltage Sensing Module Without DRIVE-CLiQ cable	6SL3053-0AA00-3AA1

For SINAMICS S150 and SINAMICS S120 Cabinet Modules, to implement the flying restart function, VSM10 can be ordered as an option with order code **K51**.

Technical specifications

VSM10 Voltage Sensing Module 6SL3053-0AA00-3AA1	
Power requirement, max. at 24 V DC	0.2 A
• Conductor cross-section, max.	2.5 mm ²
Power loss, max.	10 W
Line voltage detection	
• Insulation resistance neutral point – ground when jumper is not inserted	>10 MΩ
• Input resistance	
- Terminal X521	>362 kΩ/phase
- Terminal X522	>2.5 MΩ/phase
Analog inputs (reserved for monitoring an Active Interface Module in chassis format)	
• Internal resistance, approx. (between differential inputs)	100 kΩ
• Resolution	12 bits
PE connection	M4 screw
Dimensions	
• Width	50 mm
• Height	150 mm
• Depth	111 mm
Weight, approx.	0.9 kg

SINAMICS S120 Chassis Format Converter Units

System components

Supplementary system components > VSM10 Voltage Sensing Module

Integration

The VSM10 Voltage Sensing Module communicates with the CU310-2 or CU320-2 Control Unit via DRIVE-CLiQ.

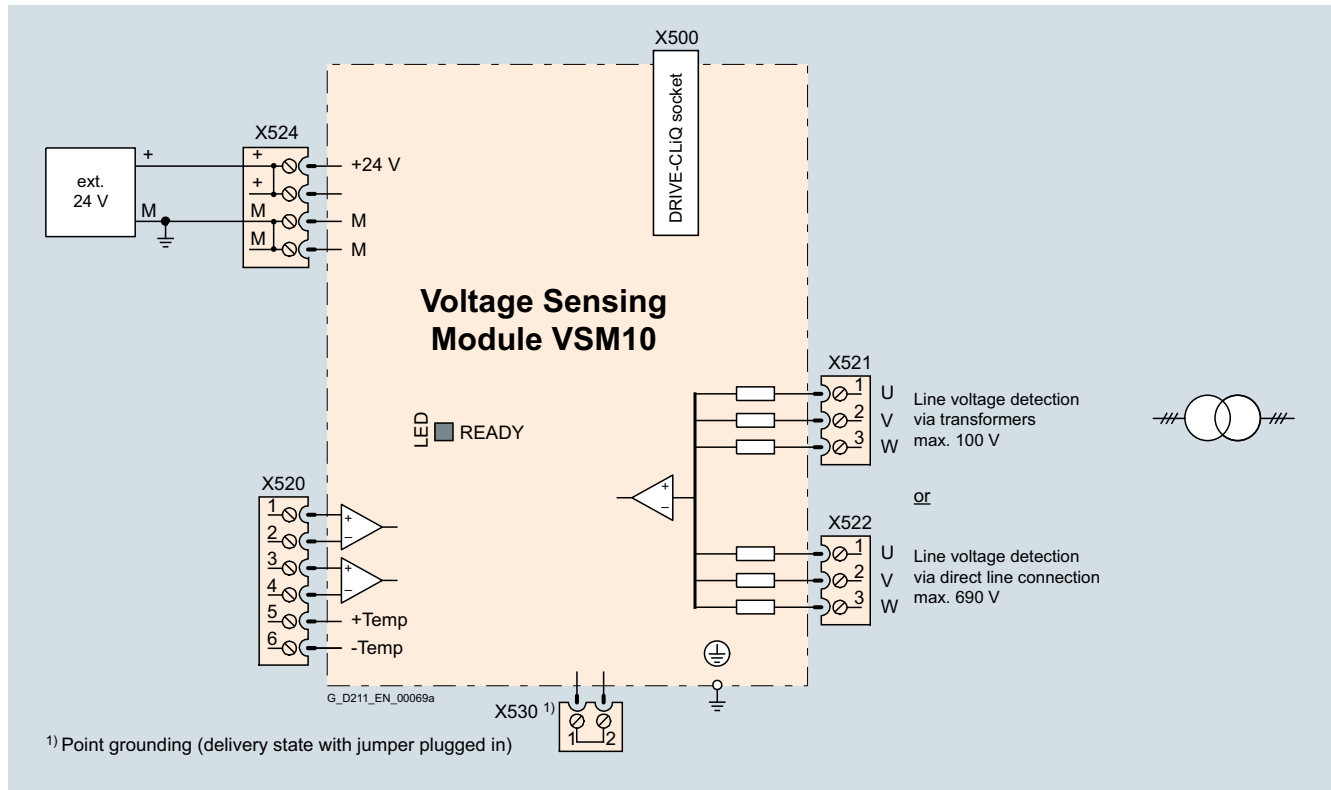

Connection example of a VSM10 Voltage Sensing Module

SINAMICS S120 Chassis Format Converter Units

System components

Supplementary system components > Safe Brake Adapter SBA

Overview



For SINAMICS S120, S150, G130 and G150 units, a Safe Brake Adapter SBA is required to safely control a motor holding brake via the Safe Brake Control (SBC) safety function according to IEC 61800-5-2.

The Safe Brake Adapter is available for a 230 V AC brake control voltage.

It can be ordered as supplementary component for SINAMICS S120 chassis format units as well as for SINAMICS G130 chassis units.

It is available as option (**K88**) for SINAMICS S120 Cabinet Modules and SINAMICS S150 or G150 cabinet units.

Note:

The SBA is approved for the IEC area. Safe Brake Adapter with UL approval are available on request. The UL approval is valid for a maximum permissible current consumption of 1.5 A (inductive).

Design

The Safe Brake Adapter SBA has the following connections and interfaces:

- 1 connection for the connecting cable to the Power Module/ Motor Module
- 1 connection for the external 230 V AC supply
- 1 connection for motor holding brake
- 1 connection for fast de-excitation

Selection and ordering data

Description	Article No.
Safe Brake Adapter • 230 V AC/2 A	6SL3355-2DX00-1AA0
Accessories	
Pre-assembled interface cable to connect the SBA to the electronics module (4 m)	6SL3060-4DX04-0AA0

Technical specifications

Safe Brake Adapter 6SL3355-2DX00-1AA0	
Electronics power supply	
Supply voltage (via the Control Interface Module)	24 V DC (20.4 ... 28.8 V DC)
Supply voltage of the motor holding brake	230 V AC
Current consumption, max perm. ¹⁾	
• Motor holding brake	2 A
• Fast de-energization	2 A
Cable length, max.	
• To the Control Interface Module	10 m
• To the brake	300 m
Conductor cross-section	2.5 mm ²
Dimensions	
• Width	75 mm
• Height	111 mm
• Depth	89 mm
Weight, approx.	0.25 kg
Safety Integrated	Safety Integrity Level 2 (SIL2) acc. to IEC 61508, Performance Level d (PLd) acc. to ISO 13849-1 and Control Category 3 acc. to EN ISO 13849-1

¹⁾ The UL approval is valid for a maximum permissible current consumption of 1.5 A (inductive).

SINAMICS S120 Chassis Format Converter Units

System components

Supplementary system components > Safe Brake Adapter SBA

Integration

The SBC function is controlled and monitored by the SINAMICS Drives firmware. The control and feedback signal regarding the switching state of the SBA relay is implemented via terminals of the Control Interface Module (CIM). The excitation coil of the holding brake is connected directly at the SBA.

For the SINAMICS S120 units, chassis format, the brake supply voltage must be connected externally at the SBA.

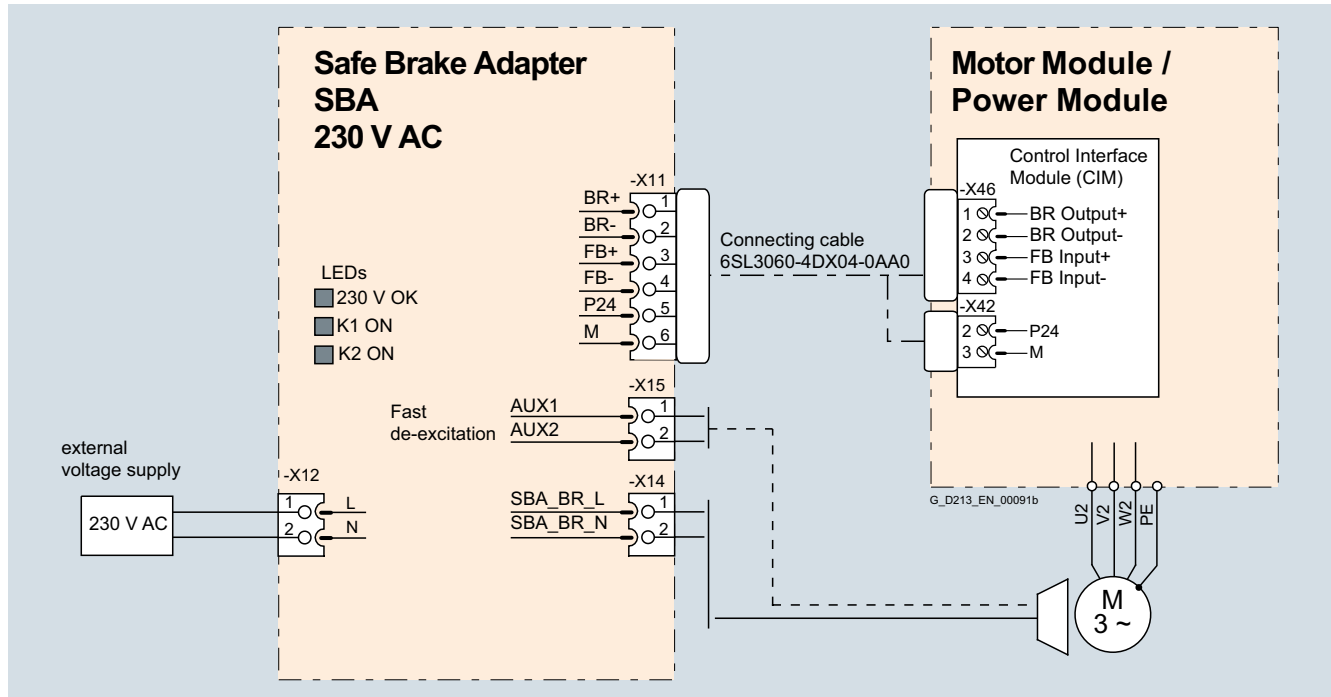

Connection example of a Safe Brake Adapter SBA

Overview***Motors without DRIVE-CLiQ interface***

The encoder and temperature signals of motors without DRIVE-CLiQ interfaces, as well as those of external encoders, must be connected via Sensor Modules. Sensor Modules Cabinet-Mounted are available in degree of protection IP20 for control cabinet installation, as well as Sensor Modules External-Mounted in degree of protection IP67.

Only one encoder system can be connected to each Sensor Module.

More information

Motor encoder and temperature signals must be connected to the corresponding Motor Module or Power Module and external encoders to the Control Unit. However, the DRIVE-CLiQ connections can also be bundled via DRIVE-CLiQ Hub Modules.

Safety Integrated

Suitable encoders are required in order to allow unrestricted use of Safety Integrated Extended Functions.

Belt-driven motor

Unfavorable material combinations generate static electricity between the belt pulley and the belt. Electrostatic charging must be prevented, since this can discharge via the motor shaft and the encoder, thereby causing disturbances in the encoder signals. One remedy is to use an anti-static belt.

SINAMICS S120 Chassis Format Converter Units

Encoder system connection

SMC10 Sensor Module Cabinet-Mounted

Overview



The SMC10 Sensor Module Cabinet-Mounted is required to evaluate the encoder signals of motors without a DRIVE-CLiQ interface. External encoders can also be connected via the SMC10.

The following encoder signals can be evaluated:

- 2-pole resolver
- Multi-pole resolver

Design

The SMC10 Sensor Module Cabinet-Mounted features the following connections and interfaces as standard:

- 1 encoder connection including motor temperature detection (KTY84-130 or PTC) via SUB-D connector
- 1 DRIVE-CLiQ interface
- 1 connection for the electronics power supply via the 24 V DC power supply connector
- 1 PE (protective earth) connection

The status of the SMC10 Sensor Module Cabinet-Mounted is indicated via a multi-color LED.

The SMC10 Sensor Module Cabinet-Mounted can be snapped onto a TH 35 standard mounting rail in accordance with EN 60715 (IEC 60715).

The signal cable shield is connected via the encoder system connector and can also be connected to the SMC10 Sensor Module Cabinet-Mounted via a shield connection terminal, e.g. Phoenix Contact type SK8 or Weidmüller type KLBÜ CO 1. The shield connection terminal must not be used for strain relief.

Selection and ordering data

Description	Article No.
SMC10 Sensor Module Cabinet-Mounted Without DRIVE-CLiQ cable	6SL3055-0AA00-5AA3

For the SINAMICS S150 and SINAMICS S120 Cabinet Modules, the SMC10 Sensor Module Cabinet-Mounted can be ordered as an option by specifying order code **K46**.

Integration

SMC10 Sensor Modules Cabinet-Mounted communicate with a Control Unit via DRIVE-CLiQ.

Technical specifications

SMC10 Sensor Module Cabinet-Mounted 6SL3055-0AA00-5AA3	
Power requirement, max. at 24 V DC, not taking encoder into account	0.2 A
<ul style="list-style-type: none"> • Conductor cross-section, max. • Fuse protection, max. 	2.5 mm ² 20 A
Power loss, max.	10 W
Encoders which can be evaluated	<ul style="list-style-type: none"> • 2-pole resolvers • Multi-pole resolver
<ul style="list-style-type: none"> • Excitation voltage, rms • Excitation frequency 	4.1 V 5 ... 10 kHz depending on the current controller clock cycle of the Motor Module or Power Module
<ul style="list-style-type: none"> • Transformation ratio • Encoder frequency, max. 	0.5 2 kHz (120000 rpm) depending on the number of resolver pole pairs and current controller clock cycle of the Motor Module or Power Module
<ul style="list-style-type: none"> • Signal subdivision (interpolation), max. • Cable length to encoder, max. 	16384 times (14 bits) 130 m
PE connection	M4 screw
Dimensions	
<ul style="list-style-type: none"> • Width • Height • Depth 	30 mm 150 mm 111 mm
Weight, approx.	0.4 kg

SINAMICS S120 Chassis Format Converter Units

Encoder system connection

SMC20 Sensor Module Cabinet-Mounted

Overview



The SMC20 Sensor Module Cabinet-Mounted is required to evaluate the encoder signals of motors without a DRIVE-CLiQ interface. External encoders can also be connected via the SMC20.

The following encoder signals can be evaluated:

- Incremental encoder sin/cos $1 V_{pp}$
- Absolute encoder EnDat 2.1
- SSI encoder with incremental signals sin/cos $1 V_{pp}$ (firmware version 2.4 and later)

The motor temperature can also be detected using KTY84-130 or PTC thermistors.

Design

The SMC20 Sensor Module Cabinet-Mounted features the following connections and interfaces as standard:

- 1 encoder connection including motor temperature detection (KTY84-130 or PTC) via SUB-D connector
- 1 DRIVE-CLiQ interface
- 1 connection for the electronics power supply via the 24 V DC power supply connector
- 1 PE (protective earth) connection

The status of the SMC20 Sensor Module Cabinet-Mounted is indicated via a multi-color LED.

The SMC20 Sensor Module Cabinet-Mounted can be snapped onto a TH 35 standard mounting rail in accordance with EN 60715 (IEC 60715).

The signal cable shield is connected via the encoder system connector and can also be connected to the SMC20 Sensor Module Cabinet-Mounted via a shield connection terminal, e.g. Phoenix Contact type SK8 or Weidmüller type KLBÜ CO 1. The shield connection terminal must not be used for strain relief.

Selection and ordering data

Description	Article No.
SMC20 Sensor Module Cabinet-Mounted	6SL3055-0AA00-5BA3
Without DRIVE-CLiQ cable	

For the SINAMICS S150 and SINAMICS S120 Cabinet Modules, the SMC20 Sensor Module Cabinet-Mounted can be ordered as an option by specifying order code **K48**.

Integration

SMC20 Sensor Modules Cabinet-Mounted communicate with a Control Unit via DRIVE-CLiQ.

Technical specifications

SMC20 Sensor Module Cabinet-Mounted 6SL3055-0AA00-5BA3	
Power requirement, max. at 24 V DC, without taking encoder into account	0.2 A
• Conductor cross-section, max.	2.5 mm ²
• Fuse protection, max.	20 A
Power loss, max.	10 W
Encoders which can be evaluated	<ul style="list-style-type: none"> • Incremental encoder sin/cos $1 V_{pp}$ • Absolute encoder EnDat 2.1 • SSI encoder with incremental signals sin/cos $1 V_{pp}$ (firmware version 2.4 and later)
• Encoder supply	5 V DC/0.35 A
• Encoder frequency incremental signals, max.	500 kHz
• Signal subdivision (interpolation), max.	16384 times (14 bits)
• SSI baud rate	100 kBaud
• Cable length to encoder, max.	100 m
PE connection	M4 screw
Dimensions	
• Width	30 mm
• Height	150 mm
• Depth	111 mm
Weight, approx.	0.45 kg

SINAMICS S120 Chassis Format Converter Units

Encoder system connection

SMC30 Sensor Module Cabinet-Mounted

Overview



The SMC30 Sensor Module Cabinet-Mounted is required to evaluate the encoder signals of motors without a DRIVE-CLiQ interface. External encoders can also be connected via the SMC30.

The following encoder signals can be evaluated:

- Incremental encoders TTL/HTL with/without open-circuit detection (open-circuit detection is only available with bipolar signals)
- SSI encoder with TTL/HTL incremental signals
- SSI encoder without incremental signals

The motor temperature can also be detected using KTY84-130 or PTC thermistors.

Design

The SMC30 Sensor Module Cabinet-Mounted features the following connections and interfaces as standard:

- 1 encoder connection including motor temperature sensing (KTY84-130 or PTC) either via SUB-D connector or via terminals
- 1 DRIVE-CLiQ interface
- 1 connection for the electronics power supply via the 24 V DC supply connector
- 1 PE connection

The status of the SMC30 Sensor Module Cabinet-Mounted is indicated using a multi-color LED.

The SMC30 Sensor Module Cabinet-Mounted can be snapped onto a TH 35 standard mounting rail in accordance with EN 60715 (IEC 60715).

The maximum encoder cable length between SMC30 modules and encoders is 100 m. For HTL encoders, this length can be increased to 300 m if the A+/A- and B+/B- signals are evaluated and the power supply cable has a minimum cross-section of 0.5 mm².

The signal cable shield can be connected to the SMC30 Sensor Module Cabinet-Mounted via a shield connection terminal, e.g., Phoenix Contact type SK8 or Weidmüller type KLBÜ CO 1. The shield connection terminal must not be used as a strain relief mechanism.

Selection and ordering data

Description	Article No.
SMC30 Sensor Module Cabinet-Mounted Without DRIVE-CLiQ cable	6SL3055-0AA00-5CA2

For the SINAMICS S150 and SINAMICS S120 Cabinet Modules, the SMC30 Sensor Module Cabinet-Mounted can be ordered as an option by specifying order code **K50**.

Integration

SMC30 Sensor Modules Cabinet-Mounted communicate with a Control Unit via DRIVE-CLiQ.

Technical specifications

SMC30 Sensor Module Cabinet-Mounted 6SL3055-0AA00-5CA2	
Power requirement, max. at 24 V DC, without taking encoder into account	0.2 A
• Conductor cross-section, max.	2.5 mm ²
• Fuse protection, max.	20 A
Power loss, max.	10 W
Encoders which can be evaluated	<ul style="list-style-type: none"> • Incremental encoder TTL/HTL • SSI encoder with TTL/HTL incremental signals • SSI encoder without incremental signals
• Input impedance	
- TTL	570 Ω
- HTL, max.	16 mA
• Encoder supply	
	24 V DC/0.35 A or 5 V DC/0.35 A
• Encoder frequency, max.	300 kHz
• SSI baud rate	100 ... 250 kBaud
• Limiting frequency	300 kHz
• Resolution absolute position SSI	30 bits
• Cable length, max.	
- TTL encoder	100 m (only bipolar signals permitted) ¹⁾
- HTL encoder	100 m for unipolar signals 300 m for bipolar signals ¹⁾
- SSI encoder	100 m
PE connection	M4 screw
Dimensions	
• Width	30 mm
• Height	150 mm
• Depth	111 mm
Weight, approx.	0.45 kg

¹⁾ Signal cables twisted in pairs and shielded.

Overview

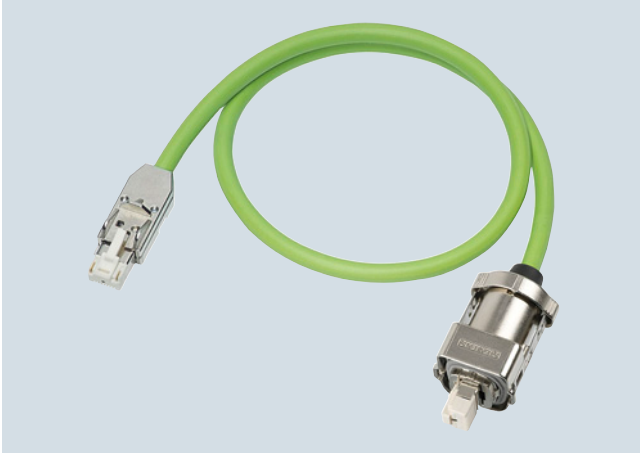

MOTION-CONNECT DRIVE-CLiQ signal cable with IP20/IP67 connector

Signal cables are required for the DRIVE-CLiQ connection between different components. Signal cables are pre-assembled and are sold by the meter. The following signal cables are available:

- DRIVE-CLiQ signal cables
- MOTION-CONNECT DRIVE-CLiQ signal cables
- MOTION-CONNECT pre-assembled signal cables

Type of delivery for pre-assembled signal cables

Pre-assembled signal cables are available in units of 10 cm.

The cables are supplied on reels up to 30 kg or 100 m. Above 30 kg or 100 m, cable drums are used instead of reels.

Application

DRIVE-CLiQ signal cables

are used to connect components with DRIVE-CLiQ connections which have a separate or external 24 V DC power supply.

MOTION-CONNECT DRIVE-CLiQ signal cables

are used whenever components with DRIVE-CLiQ connections must meet high requirements such as mechanical stress and oil resistance, e.g. when connections are made outside the cabinet between

- Motor Modules and Sensor Modules
- Motor Modules and motors with DRIVE-CLiQ interface
- Motor Modules and direct measuring systems with DRIVE-CLiQ interface (incl. non-Siemens measuring systems)

MOTION-CONNECT DRIVE-CLiQ signal cables have 24 V DC cores.

MOTION-CONNECT pre-assembled signal cables

are used whenever motor encoders on motors without DRIVE-CLiQ interface are connected to Sensor Modules.

Note:

All 6FX.002-2C... signal cables are also available with crimped contacts and connector housing supplied as a separate accessory.

- Signal cables with **motor-side** connector housing supplied as a separate accessory. In this case, the 6th position of the Article No. must be changed from 0 to 4: 6FX.042-2C...-....
- Signal cables with **module-side** connector housing supplied as a separate accessory. In this case, the 6th position of the Article No. must be changed from 0 to 1: 6FX.012-2C...-....

Once the contacts have latched into the insulator, they can no longer be removed.

SINAMICS S120 Chassis Format Converter Units

Connection system

Signal cables**Selection and ordering data**

Signal cable	Length	Degree of protection (connector)	Basic cable Article No.
Pre-assembled DRIVE-CLiQ signal cables (without 24 V DC cores)			
In specific lengths	0.11 m	IP20/IP20	6SL3060-4AB00-0AA0
	0.16 m		6SL3060-4AD00-0AA0
	0.21 m		6SL3060-4AF00-0AA0
	0.26 m		6SL3060-4AH00-0AA0
	0.31 m		6SL3060-4AK00-0AA0
	0.36 m		6SL3060-4AM00-0AA0
	0.41 m		6SL3060-4AP00-0AA0
	0.60 m		6SL3060-4AU00-0AA0
	0.95 m		6SL3060-4AA10-0AA0
	1.20 m		6SL3060-4AW00-0AA0
	1.45 m		6SL3060-4AF10-0AA0
	2.80 m		6SL3060-4AJ20-0AA0
	5.00 m		6SL3060-4AA50-0AA0
	To the meter		Max. 70 m
Max. 70 m		IP67/IP67	6FX2002-1DC20-....
DRIVE-CLiQ MOTION-CONNECT 500 signal cables (with 24 V DC cores)			
To the meter	Max. 100 m	IP20/IP20	6FX5002-2DC00-....
	Max. 100 m	IP20/IP67	6FX5002-2DC10-....
	Max. 100 m	IP67/IP67	6FX5002-2DC20-....
DRIVE-CLiQ MOTION-CONNECT 800PLUS signal cables (with 24 V DC cores)			
To the meter	Max. 50 m	IP20/IP20	6FX8002-2DC00-....
	Max. 50 m	IP20/IP67	6FX8002-2DC10-....
	Max. 50 m	IP67/IP67	6FX8002-2DC20-....

Selection and ordering data (continued)

Length codes

Description	Article No. supplement				
Length codes for pre-assembled cables					
	6FX-.....-	<input type="checkbox"/>	<input type="checkbox"/>	<input type="checkbox"/>	<input type="checkbox"/>
	6SX-.....-	<input type="checkbox"/>	<input type="checkbox"/>	<input type="checkbox"/>	0
0 m		1			
100 m		2			
200 m		3			
0 m			A		
10 m			B		
20 m			C		
30 m			D		
40 m			E		
50 m			F		
60 m			G		
70 m			H		
80 m			J		
90 m			K		
0 m			A		
1 m			B		
2 m			C		
3 m			D		
4 m			E		
5 m			F		
6 m			G		
7 m			H		
8 m			J		
9 m			K		
0 m					0
0.1 m					1
0.2 m					2
0.3 m					3
0.4 m					4
0.5 m					5
0.6 m					6
0.7 m					7
0.8 m					8
Examples:	1.0 m:	1	A	B	0
	2.2 m:	1	A	C	2
	8.0 m:	1	A	J	0
	299.0 m:	3	K	K	0

Refer to Catalog PM 21 for further information about DRIVE-CLiQ signal cables.

SINAMICS S120 Chassis Format Converter Units

Connection system

Signal cables

Integration

Connection overview for the CU320-2 Control Unit

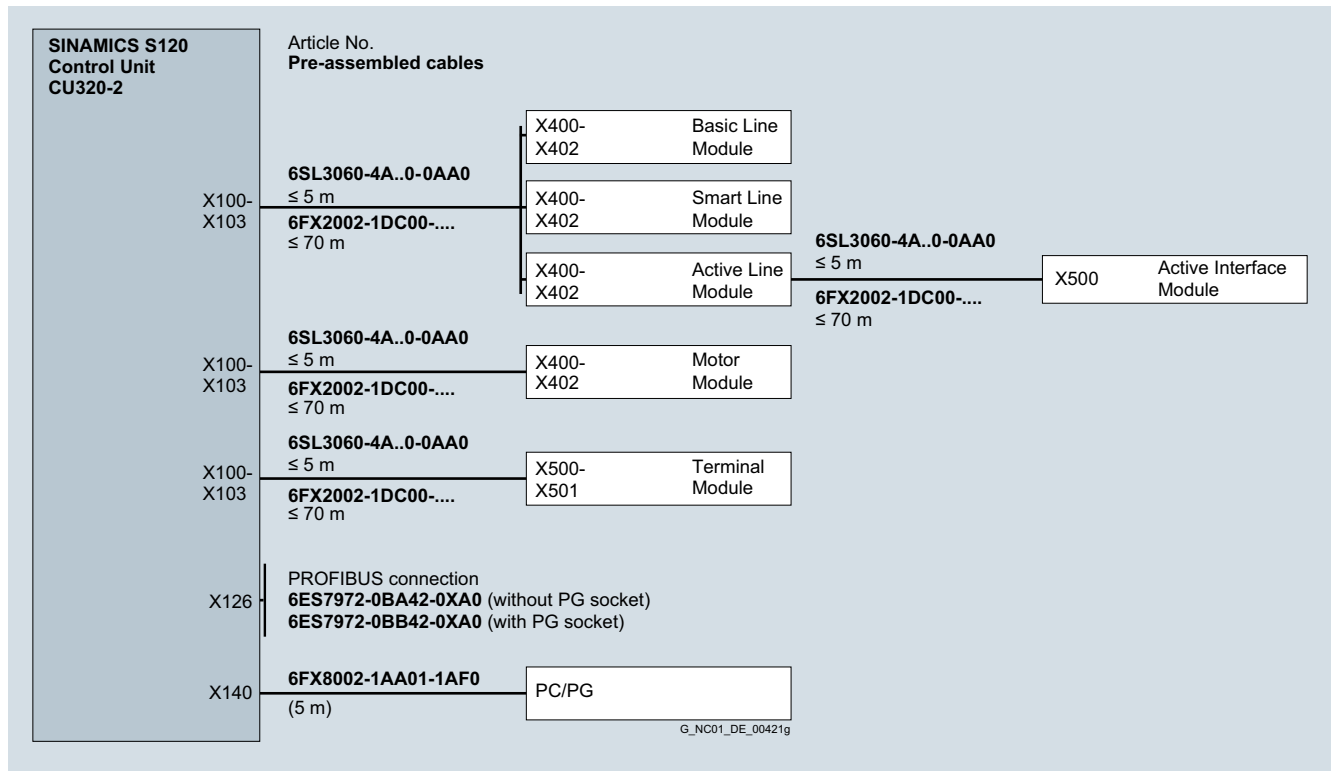

Connection overview for the SINAMICS S120 CU320-2 Control Unit

Integration (continued)

Connection overview for Line Modules and Motor Modules

The DRIVE-CLiQ type 6SL3060-4A..0-0AA0 cables for the standard configuration are part of the scope of supply of the Line Modules and Motor Modules. In this case, the modules must be mounted directly adjacent in a line.

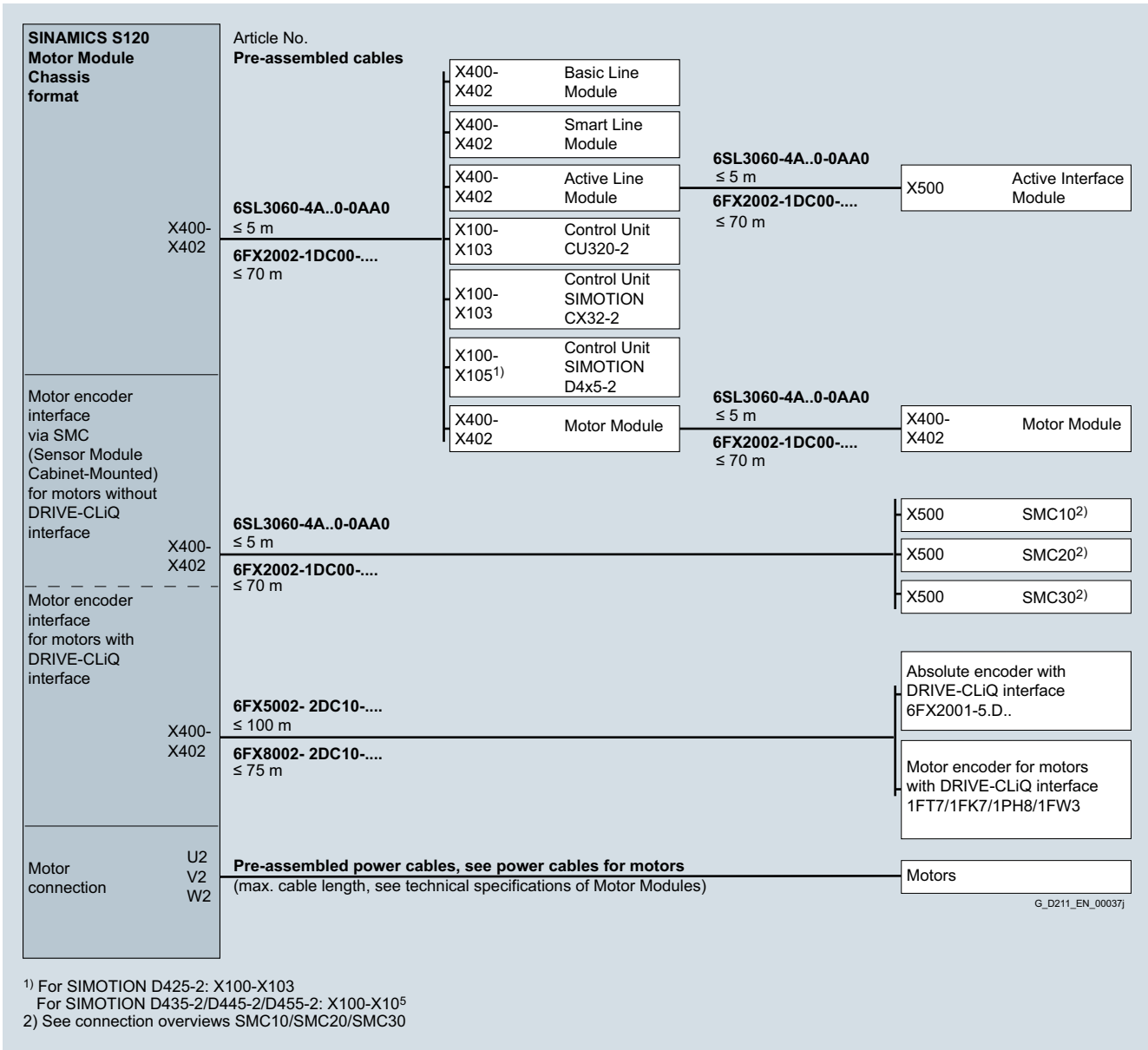

1) For SIMOTION D425-2: X100-X103
For SIMOTION D435-2/D445-2/D455-2: X100-X105
2) See connection overviews SMC10/SMC20/SMC30

Connection overview for chassis type Line Modules and Motor Modules

SINAMICS S120 Chassis Format Converter Units

Connection system

Signal cables

Integration (continued)

Connection overview for Power Modules

A DRIVE-CLiQ cable of type 6SL3060-4A..0-0AA0 for connection to the chassis-mounted CU310-2 Control Unit is already included in the scope of supply.

SINAMICS S120 Power Module		Article No.	Pre-assembled cables	
Chassis format	Line connection U1/L1 V1/L2 W1/L3	Power supply cables, see power cables for motors (by the meter)		X100 SINAMICS S120 Control Unit CU310-2
		X400- X402	6SL3060-4A..0-0AA0 ≤ 5 m	X100- X103 SINAMICS S120 Control Unit CU320-2
Motor encoder interface via SMC (Sensor Module Cabinet-Mounted) for motors without DRIVE-CLiQ interface	X402		6FX2002-1DC00-.... ≤ 70 m	X100 Control Unit SIMOTION D410-2
		6SL3060-4A..0-0AA0 ≤ 5 m	X100- X105 ¹⁾ Control Unit SIMOTION D4x5-2	
Motor encoder interface for motors with DRIVE-CLiQ interface	X402	6FX2002-1DC00-.... ≤ 70 m	X100- X103 Control Unit SIMOTION CX32-2	
		6FX5002-2DC10-.... ≤ 100 m	X500- X501 Terminal Module	
Motor encoder interface for motors with DRIVE-CLiQ interface	X402	6FX8002-2DC10-.... ≤ 75 m	X400- X402 Power Module	
		6FX5002-2DC10-.... ≤ 100 m	X500 SMC10 ²⁾	
Motor connection	U2 V2 W2	Pre-assembled power cables, see power cables for motors (max. cable length, see technical specifications of Motor Modules)		X500 SMC20 ²⁾
				X500 SMC30 ²⁾
				Motor encoder for motors with DRIVE-CLiQ interface 1FT7/1FK7/1PH8/1FW3
				Motors

G_D211_EN_00139h

¹⁾ For SIMOTION D425-2: X100-X103
For SIMOTION D435-2/D445-2/D455-2: X100-X105
²⁾ See connection overviews SMC10/SMC20/SMC30

Connection overview for Power Modules of chassis format

Integration (continued)

Connection of a machine encoder (direct measuring system)

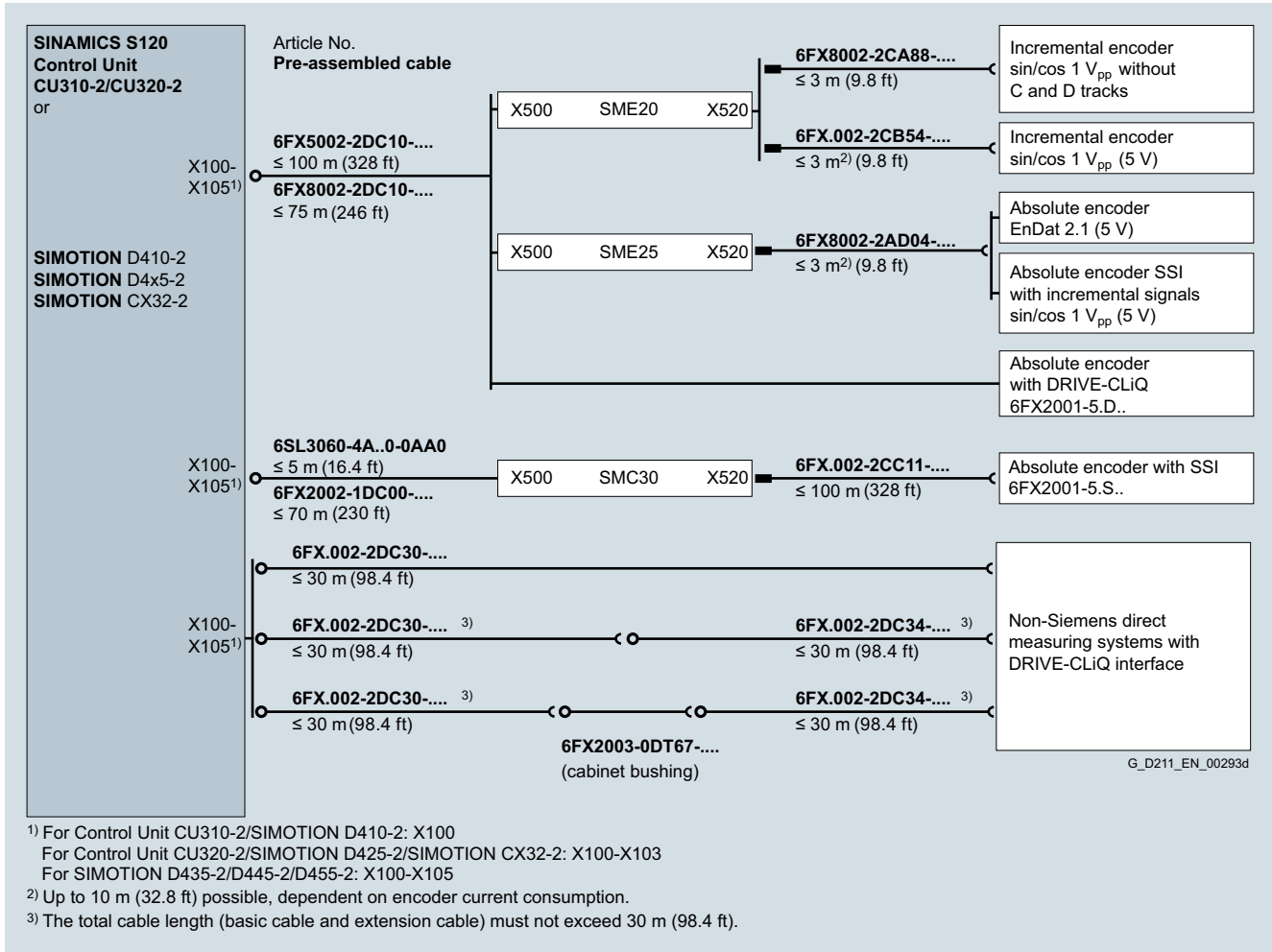

SINAMICS S120 Chassis Format Converter Units

Connection system

Signal cables

Technical specifications

Signal cables	MOTION-CONNECT 500 6FX500-.....-....	MOTION-CONNECT 800PLUS 6FX800-.....-....
Approvals, according to		
• cURus or UR/CSA	UL758-CSA-C22.2-N.210.2-M90	UL758-CSA-C22.2-N.210.2-M90
• UR-CSA File No. ¹⁾	Yes	Yes
• RoHS conformity	Yes	Yes
Rated voltage according to EN 50395	30 V	30 V
Test voltage, rms	500 V	500 V
Operating temperature on the surface		
• Permanently installed	-20 ... +80 °C	-50 ... +80 °C
• Flexible installation	0 ... 60 °C	-20 ... +60 °C
Tensile stress, max.		
• Permanently installed	50 N/mm ²	50 N/mm ²
• Flexible installation	20 N/mm ²	20 N/mm ²
Smallest bending radius		
• Permanently installed	60 mm	4 × D _{max}
• Flexible installation	100 mm	70 mm
Torsional stress	Absolute 30°/m	Absolute 30°/m
Bending operations	2 million	10 million
Traversing speed	180 m/min	Up to 300 m/min
Acceleration	5 m/s ²	Up to 50 m/s ²
Insulation material, incl. jacket	CFC/silicone-free	CFC/halogen/silicone-free IEC 60754-1/DIN VDE 0472-815
Oil resistance	EN 60811-2-1 (mineral oil only)	EN 60811-2-1
Jacket	PVC DESINA color green RAL 6018	PUR, HD22.10 S2 (VDE 0282, Part 10) DESINA color green RAL 6018
Flame-retardant	EN 60332-1-1 to 1-3	EN 60332-1-1 to 1-3

Degree of protection of the pre-assembled signal cables and their extensions when closed and inserted: IP67.

¹⁾ The File No. is printed on the cable jacket.

SINAMICS S120 Chassis Format Converter Units

Connection system

Signal cables

Technical specifications (continued)

DRIVE-CLiQ signal cables	DRIVE-CLiQ 6FX2...-1DC...-....	DRIVE-CLiQ MOTION-CONNECT 500 6FX5...-DC...-....	DRIVE-CLiQ MOTION-CONNECT 800PLUS 6FX8...-DC...-....
Approvals, according to			
• cURus or UR/CSA	UL STYLE 2502/CSA-N.210.2-M90	UL STYLE 2502/CSA-N.210.2-M90	UL STYLE 2502/CSA-N.210.2-M90
• UR-CSA File No. ¹⁾	Yes	Yes	Yes
• RoHS conformity	Yes	Yes	Yes
Rated voltage according to EN 50395	30 V	30 V	30 V
Test voltage, rms	500 V	500 V	500 V
Operating temperature on the surface			
• Permanently installed	-20 ... +80 °C	-20 ... +80 °C	-50 ... +80 °C
• Flexible installation	–	0 ... 60 °C	-20 ... +60 °C
Tensile stress, max.			
• Permanently installed	45 N/mm ²	80 N/mm ²	50 N/mm ²
• Flexible installation	–	30 N/mm ²	20 N/mm ²
Smallest bending radius			
• Permanently installed	50 mm	35 mm	35 mm
• Flexible installation	–	125 mm	75 mm
Torsional stress	–	Absolute 30°/m	Absolute 30°/m
Bending operations	–	100000	10 million
Traversing speed	–	30 m/min	30 m/min
Acceleration	–	2 m/s ²	Up to 50 m/s ²
Insulation material, incl. jacket	CFC/silicone-free	CFC/silicone-free	CFC/halogen/silicone-free IEC 60754-1/DIN VDE 0472-815
Oil resistance	EN 60811-2-1	EN 60811-2-1 (mineral oil only)	EN 60811-2-1
Jacket	PVC Gray RAL 7032	PVC DESINA color green RAL 6018	PUR, HD22.10 S2 (VDE 0282, Part 10) DESINA color green RAL 6018
Flame-retardant	EN 60332-1-1 to 1-3	EN 60332-1-1 to 1-3	EN 60332-1-1 to 1-3

Degree of protection of the pre-assembled signal cables and their extensions when closed and inserted: IP67.

More information

Further information is available:

- Interactive Catalog CA 01
- Internet
 - www.siemens.com/motion-connect
 - www.siemens.com/industrymall

¹⁾ The File No. is printed on the cable jacket.

SINAMICS S120 Chassis Format Converter Units

Notes

3

SINAMICS S120 Cabinet Modules



4/2	System overview
4/2	Overview
4/3	Benefits
4/4	Application
4/4	Design
4/5	Function
4/7	Technical specifications
4/8	Air-cooled units
4/15	Line Connection Modules
4/22	Basic Line Modules
4/27	Smart Line Modules
4/31	Active Line Modules including Active Interface Modules
4/37	Motor Modules Booksize format
4/41	Motor Modules Chassis format
4/48	Central Braking Modules
4/52	Auxiliary Power Supply Modules
4/55	Customer terminal block -X55
4/58	Liquid-cooled units
4/65	Basic Line Connection Modules
4/69	Active Line Connection Modules
4/73	Motor Modules
4/79	Heat Exchanger Modules
4/83	Options
4/83	Overview
4/89	Option selection matrix
4/91	Description of the options
4/106	Supplementary system components
4/106	Mounting device for air-cooled power blocks
4/107	Order-specific integration engineering
4/107	Option selection matrix of the order-specific integration engineering
4/108	Customized solutions

SINAMICS S120 Cabinet Modules

System overview

Overview



SINAMICS S120 Cabinet Modules, air-cooled and liquid-cooled

SINAMICS S120 Cabinet Modules are the components of a modular cabinet system for multi-motor drives with a central supply infeed and a common DC link busbar, as used, for example, in the process industry, automotive industry, metal processing industry as well as in the crane and mining domains. They are available in air-cooled or liquid-cooled versions. As standard, they are installed side by side in a row. Other installation types (e.g. back to back) are possible on request. SINAMICS S120 Cabinet Modules include the chassis units from the SINAMICS S120 series in booksize format (Motor Modules) and chassis format, thus making the range an ideal supplement to the SINAMICS G150 and SINAMICS S150 cabinet converter series for single-motor drives.

All drive components, from the supply infeed to the motor-side inverters, are configured in a clear, compact layout in the individual Cabinet Modules. They can be flexibly combined and optimally adapted to customer-specific requirements thanks to a comprehensive array of options.

The main components of the air-cooled system are as follows:

- Line Connection Modules with line-side components such as contactors, fuses and circuit breakers, as well as line reactors for Basic Line Modules
- The following types of infeed Line Modules:
 - Basic Line Modules for two-quadrant operation
 - Smart Line Modules for four-quadrant operation
 - Active Line Modules for four-quadrant operation with negligible line harmonics
- Central Braking Modules for braking operation
- The following types of Motor Modules:
 - Booksize Cabinet Kit
 - Chassis
- Control Units
- Auxiliary Power Supply Modules to supply the auxiliary power supply system

The main components of the liquid-cooled system are as follows:

- Active Line Connection Modules as a combination of Line Connection Module and Active Line Module with an Active Interface Module
- Basic Line Connection Modules as a combination of a Line Connection Module and a Basic Line Module
- Motor Modules
- Control Units
- Heat Exchanger Modules with pumps, closed-loop control and a heat exchanger between the deionized water and raw water circuits

Standardized interfaces for both the power and the control connections facilitate engineering and installation. Communication between the power modules and the central Control Unit takes place via DRIVE-CLiQ, the internal drive serial interface.

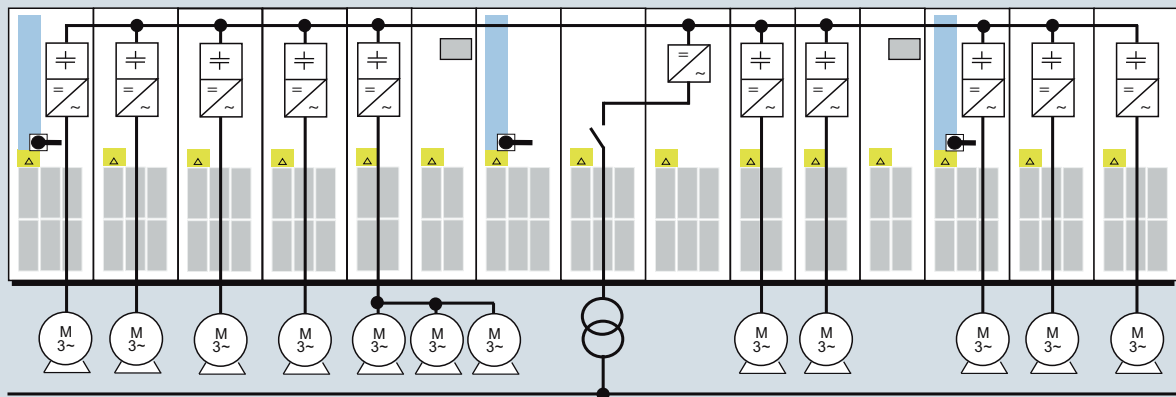

Example of a drive line-up with SINAMICS S120 Cabinet Modules for a multi-motor drive

Overview (continued)

The following tables provide an overview of the voltage ranges and power ratings of the available SINAMICS S120 Cabinet Modules.

Voltage ranges and powers for air-cooled SINAMICS S120 Cabinet Modules

	Line voltage	Input current	DC link voltage	DC link current	Output current	Power range of single modules
Line Connection Modules ¹⁾	380 ... 480 V 3 AC	250 ... 3200 A	–	–	–	–
	500 ... 690 V 3 AC	280 ... 3200 A	–	–	–	–
Basic Line Modules ¹⁾	380 ... 480 V 3 AC	365 ... 1630 A	510 ... 650 V	420 ... 1880 A	–	200 ... 900 kW
	500 ... 690 V 3 AC	260 ... 1580 A	675 ... 930 V	300 ... 1880 A	–	250 ... 1500 kW
Smart Line Modules ¹⁾	380 ... 480 V 3 AC	463 ... 1430 A	510 ... 650 V	550 ... 1700 A	–	250 ... 800 kW
	500 ... 690 V 3 AC	463 ... 1430 A	675 ... 930 V	550 ... 1700 A	–	450 ... 1400 kW
Active Line Modules ¹⁾	380 ... 480 V 3 AC	210 ... 1405 A	540 ... 720 V	235 ... 1574 A	–	132 ... 900 kW
	500 ... 690 V 3 AC	575 ... 1270 A	710 ... 1035 V	644 ... 1422 A	–	560 ... 1400 kW
Motor Modules Booksize	380 ... 480 V 3 AC	–	510 ... 720 V	–	9 ... 132 A	4.8 ... 71 kW
Motor Modules Chassis ¹⁾	380 ... 480 V 3 AC	–	510 ... 720 V	–	210 ... 1405 A	110 ... 800 kW
	500 ... 690 V 3 AC	–	675 ... 1035 V	–	85 ... 1270 A	75 ... 1200 kW
Central Braking Modules ¹⁾	380 ... 480 V 3 AC	–	510 ... 720 V	–	–	500 ... 1000 kW
	500 ... 600 V 3 AC	–	675 ... 900 V	–	–	550 ... 1100 kW
	660 ... 690 V 3 AC	–	890 ... 1035 V	–	–	630 ... 1200 kW
Auxiliary Power Supply Modules	380 ... 690 V 3 AC	125 ... 250 A	–	–	–	–

Voltage ranges and power ratings for liquid-cooled SINAMICS S120 Cabinet Modules

	Line voltage	Input current	DC link voltage	DC link current	Output current	Power range of single modules
Basic Line Connection Modules ¹⁾	380 ... 480 V 3 AC	610 ... 1420 A	510 ... 650 V	740 ... 1730 A	–	360 ... 830 kW
	500 ... 690 V 3 AC	340 ... 1350 A	675 ... 930 V	420 ... 1650 A	–	355 ... 1370 kW
Active Line Connection Modules ¹⁾	380 ... 480 V 3 AC	985 ... 1405 A	540 ... 720 V	1100 ... 1573 A	–	630 ... 900 kW
	500 ... 690 V 3 AC	1025 ... 1560 A	710 ... 1035 V	1147 ... 1740 A	–	1100 ... 1700 kW
Motor Modules ¹⁾	380 ... 480 V 3 AC	–	510 ... 720 V	–	605 ... 1405 A	315 ... 800 kW
	500 ... 690 V 3 AC	–	675 ... 1035 V	–	465 ... 1560 A	450 ... 1500 kW

Benefits

The outstanding system features of the SINAMICS S120 Cabinet Modules provide the following advantages:

- Process optimization with minimum outlay
 - A standard PROFIBUS or PROFINET interface and various analog and digital interfaces enables easy integration into automation solutions
 - Vector and servo control ensures that they fulfill the most exacting requirements regarding the accuracy and dynamic response of drives
- High level of reliability and availability
 - Individual modules and power components can be replaced quickly and easily, which ensures a higher level of plant availability
- Energy saving during operation
 - The motor-side inverters are coupled via the common DC link and allow energy to be exchanged between motors that are motoring and generating. This means that energy is saved, there is less load on the supply infeed and line harmonics are reduced
- Generally the line infeed is only dimensioned for the maximum energy required when motoring or the maximum current required when motoring – and not the sum of the energy requirements of the Motor Modules connected to the DC link. As a consequence, for example, for conveyor belts or motor test stands with Motor Modules that are simultaneously operated in motoring and generating modes, a significantly smaller line infeed unit can be selected
- Minimal operative, maintenance, and servicing costs
 - Simple commissioning thanks to the menu-driven STARTER commissioning tool
 - Optional, menu-navigated AOP30 advanced operator panel with plain text display and bar-type display
 - All modules are easily accessible, making them extremely service friendly
- Space-saving design
- Environmentally-friendly operation
 - The converters are exceptionally quiet and compact thanks to state-of-the-art IGBT power semiconductors and an innovative cooling concept

¹⁾ The power can be increased by connecting up to four identical modules in parallel.

SINAMICS S120 Cabinet Modules

System overview

Application

SINAMICS S120 Cabinet Modules have been specially developed to allow simple configuration of multi-motor systems. They are used for applications where several motors must be coordinated to realize a drive task as multi-motor drives in a drive line-up. Examples of such applications include:

- Packaging machines
- Plastics processing machines
- Textile machines
- Presses and punches
- Rolling mill drives
- Hoists and cranes
- Printing and paper machines
- Vehicle and gearbox test stands
- Test stand applications
- Machines used in the woodworking, glass and ceramics industries
- Handling and assembly systems
- Machine tools

High-power single drives (parallel connection) can also be implemented with Cabinet Modules.

Design

They have been designed according to the zone concept principle and therefore offer the highest possible level of operational reliability. EMC measures have been rigorously implemented. With the help of simulated conditions, partitions have been designed to act as air guides and heat dissipation units.

Special measures used in the construction of the cabinets ensure that they remain mechanically durable over their entire life cycle.

Attention has been paid to providing a wide range of cable routing options and special design concepts are applied consistently to broaden the scope of application and simplify service. The units have all the necessary connections and connecting elements. Thanks to their carefully considered configuration concept, cabinets are shipped in a ready-to-connect state or, in the case of multiple transport units, have been prepared for quick assembly. An extensive spectrum of options designed to adapt the units to a variety of different applications facilitates the selection process.

All components, from individual parts to the ready-to-connect cabinet, undergo rigorous testing throughout the entire production process. This guarantees a high level of functional reliability during installation and commissioning, as well as in operation.

Replaceable components have been designed so that they can be quickly and easily replaced. In addition, the "Spares On Web" Internet tool makes it easy to view the spare parts that are available for the particular order at all times ¹⁾.

System design

Line Modules are coupled with the various Motor Modules by means of prefabricated busbar sets with different current carrying capacities.

All standard busbars, as well as electronics components, are protected against environmental influences. This is achieved through the use of nickel-plated copper bars and painted modules throughout.

A special, standard auxiliary power supply system supplies the individual Cabinet Modules with the required auxiliary voltages for the power components, fans and 24 V loads.

These voltages are preferably generated using an auxiliary power supply module. Additional supply possibilities are available using the **K76** option (auxiliary power supply generation in the Line Connection Module) or using an external supply in the auxiliary power supply system.

The auxiliary power supply system comprises an auxiliary power supply module with two terminal blocks (air cooling) and one auxiliary voltage terminal (liquid cooling) and a 24 V DC fuse as well as the required connecting cables. It is supplied completely assembled and ready to operate. Only the cable connections to the adjacent Cabinet Module must be established on-site.

Communication between the Control Unit, power units and other active SINAMICS components is realized via DRIVE-CLiQ connections.

DRIVE-CLiQ is an internal serial interface of the drive that enables fast and easy configuration of the complete drive line-up with prefabricated cables in varying lengths.

The Cabinet Modules can be optionally supplied in pre-configured transport units up to a total length of 2400 mm. This option is particularly recommended in air-cooled Cabinet Modules for Line Modules together with Line Connection Modules since, in this case, the Line Connection Module must be equipped with a pre-charging DC link or line reactors (depending on the type of Line Module), in addition to the electrical interface (busbar). For liquid-cooled Cabinet Modules, delivery in transport units has the advantage that the tube system of the cooling system can be implemented completely without couplings. Transport units thus enable the various devices to be quickly and easily assembled on-site.

Coated modules

The following devices are equipped with coated modules as standard:

- Booksize format units
- Chassis format units
- Control Units
- Sensor Modules
- Terminal Modules
- Advanced Operator Panel (AOP30)

The coating on the modules protects the sensitive SMD components against corrosive gases, chemically active dust and moisture.

Nickel-plated busbars

All of the copper busbars used in the converter cabinets are nickel-plated to achieve the best possible immunity to environmental effects. Furthermore, there is no need to clean the contacts on the customer terminals as otherwise required for bare copper connections.

PE bars

The Cabinet Modules are delivered with a PE bar as standard. It is used to connect and fasten PE conductors.

¹⁾ The properties of the SINAMICS S120 Cabinet Modules described in this catalog are not transferable to cabinet units constructed to meet the requirements of specific applications.

Design (continued)Note:

With some options, parts of the copper busbars cannot be nickel-plated for technical reasons.

Degrees of protection of Cabinet Modules

The EN 60529 standard covers the protection of electrical equipment by means of housings, covers or equivalent, and includes:

- Protection of persons against accidental contact with live or moving parts within the housing and protection of the equipment against the ingress of solid foreign bodies (touch protection and protection against ingress of solid foreign bodies)
- Protection of the equipment against the ingress of water (water protection)
- Abbreviations for the internationally agreed degrees of protection

The degrees of protection are specified by abbreviations comprising the code letters IP and two digits.

Degree of protection	First code number (touch protection and protection against solid foreign bodies)	Second code number (protection of the equipment against the ingress of water)
IP20 (Standard for air-cooled version)	Protected against solid foreign bodies diameter ≥ 12.5 mm	No water protection
IP21 (Standard for liquid-cooled version, option M21 for air-cooled version)	Protected against solid foreign bodies diameter ≥ 12.5 mm	Protected against drip water Vertically falling water drops shall not have a harmful effect.
IP23 (Option M23)	Protected against solid foreign bodies diameter ≥ 12.5 mm	Protected against spray water Water sprayed on both sides of the vertical at an angle of up to 60° shall not have a harmful effect.
IP43 (Option M43)	Protected against solid foreign bodies diameter ≥ 1 mm	Protected against spray water Water sprayed on both sides of the vertical at an angle of up to 60° shall not have a harmful effect.
IP54 (Air-cooled version only) (Option M54)	Dust protected Ingress of dust is not totally prevented, but dust must not be allowed to enter in such quantities that the functioning or safety of the equipment is impaired. Complete touch protection	Protected against splash water Water splashing onto the enclosure from any direction shall not have a harmful effect.
IP55 (Liquid-cooled version only) (Option M55)	Dust protected Ingress of dust is not totally prevented, but dust must not be allowed to enter in such quantities that the functioning or safety of the equipment is impaired. Complete touch protection	Protected against water jet (nozzle) Water projected by a nozzle against the enclosure from any direction shall not have a harmful effect.

Air-cooled Cabinet Modules meet degree of protection IP20, liquid-cooled Cabinet Modules degree of protection IP21, as standard. The other degrees of protection outlined here are available as an option.

Function**Communication with higher-level controller and customer terminal block**

As the customer interface to the control system, a PROFIBUS interface is available on the CU320-2 DP Control Unit or a PROFINET interface on the CU320-2 PN Control Unit as standard.

In the case of the air-cooled Cabinet Modules, the inputs and outputs available as standard on the customer terminal block -X55 are easy to access and easy to connect up. On the liquid-cooled Cabinet Modules, they are connected directly to the components.

For further information, please refer to the [SINAMICS Low Voltage Engineering Manual](#).

Open-loop and closed-loop control functions

SINAMICS S120 can use a dynamic, high-precision closed-loop vector control (drive object type VECTOR), or a highly dynamic closed-loop servo control (drive object type SERVO).

SINAMICS S120 Cabinet Modules

System overview

Function (continued)

Software and protective functions

The software functions available as standard are described below:

Software and protective functions	Description
Setpoint input	The setpoint can be specified both internally and externally; internally as a fixed setpoint, motorized potentiometer setpoint or jog setpoint, externally via the communications interface or an analog input. The internal fixed setpoint and the motorized potentiometer setpoint can be switched or adjusted via control commands from any interface.
Motor identification	The automatic motor identification function makes commissioning faster and easier and optimizes closed-loop control of the drive.
Ramp-function generator	A user-friendly ramp-function generator with separately adjustable ramp-up and ramp-down times, together with adjustable rounding times in the lower and upper speed ranges, allows the drive to be smoothly accelerated and braked. This results in a good speed control response and plays its role in reducing the stress on the mechanical system. The down ramp can be parameterized separately for a quick stop.
V_{dc max} controller	The V _{dc max} controller automatically prevents overvoltages in the DC link, if the set down ramp is too short, for example. This may also extend the set ramp-down time. <i>Note:</i> This function only makes sense for single-axis applications.
Kinetic buffering (KIP)	For brief line supply failures, the kinetic energy of the rotating drive is used to buffer the DC link and therefore prevents fault trips. The drive converter remains operational as long as the drive can provide regenerative energy as a result of its motion and the DC link voltage does not drop below the shutdown threshold. When the line supply recovers within this time, the drive is again bumplessly accelerated up to its setpoint speed.
Automatic restart	The automatic restart switches the drive on again when the power is restored after a power failure, and ramps up to the current speed setpoint.
Flying restart	The flying restart function allows the converter to be switched to a motor that is still turning. With the voltage sensing capability provided by the optional VSM10, the flying restart time for large induction motors can be significantly reduced because the motor does not need to be de-magnetized.
Technology controller	Using the technology controller (PID controller) function module, level or flow controls and complex tension controls can be implemented, for example. The existing D component can act both on the system deviation well as on the actual value (factory setting). The P, I, and D components are set separately.
Free function blocks	Using the freely programmable function blocks, it is easy to implement logic and arithmetic functions for controlling the SINAMICS drive. The blocks can be programmed at the operator panel or the STARTER commissioning tool.
Drive Control Chart (DCC)	Drive Control Chart (DCC) is an additional tool for the easy configuration of technological functions for SINAMICS. The block library contains a large selection of control, arithmetic and logic blocks as well as extensive open-loop and closed-loop control functions. The user-friendly DCC editor enables easy graphics-based configuration, allows control loop structures to be clearly represented and provides a high degree of reusability of charts that have already been created. DCC is an add-on for the STARTER commissioning tool (→ Tools and Engineering).
P_t sensing for motor protection	A motor model stored in the converter software calculates the motor temperature based on the current speed and load. More exact measurement of the temperature, which also takes into account the influence of the ambient temperature, is possible by means of direct temperature measurement using KTY84 sensors in the motor winding.
Motor temperature evaluation	Motor protection by evaluating a KTY84, PTC or Pt100 temperature sensor. When a KTY84 temperature sensor is connected, the limit values can be set for alarm or shutdown. When a PTC thermistor is connected, the system reaction to triggering of the thermistor (alarm or trip) can be defined.
Motor blocking protection	A blocked motor is detected and protected against thermal overloading by a fault trip.
Brake control	"Simple brake control" for controlling holding brakes: The holding brake is used to secure drives against unwanted motion when deactivated. The "extended braking control" function module allows complex braking control, for example, for motor holding brakes and operational brakes: In the case of brakes with feedback signal, the brake control reacts to the feedback contacts of the brake.
Write protection	Write protection to prevent unintentional changing of the setting parameters (without password function).
Know-how protection	Know-how protection for encrypting stored data, e.g. to protect expert configuring knowledge, and to protect against modification and duplication (with password function).
Web server	The integrated web server provides information about the drive unit via its web pages. The web server is accessed using a web browser via unsecured (http) or secured transfer protocol (https).

Power unit protection

Software and protective functions	Description
Ground fault monitoring at the output	A ground fault at the output is detected by a total current monitor and results in shutdown in grounded systems.
Electronic short-circuit protection at the output	A short-circuit at the output (e.g. at the converter output terminals, in the motor cable or in the motor terminal box) is detected and the converter shuts down with a "fault".
Thermal overload protection	An alarm is issued first when the overtemperature threshold responds. If the temperature continues to rise, the unit either shuts down or independently adjusts the pulse frequency or output current so that thermal load is reduced. Once the cause of the fault has been eliminated (e.g. cooling has been improved), the original operating values are automatically resumed.

Technical specifications

The most important directives and standards are listed below. These are used as basis for the SINAMICS S120 Cabinet Modules and they must be carefully observed to achieve an EMC-compliant configuration that is safe both in terms of functionally and in operation.

European directives	
2006/95/EC	Low Voltage Directive: Directive of the European Parliament and Council of December 12, 2006, on the approximation of the laws of the member states relating to electrical equipment designed for use within certain voltage limits
2004/108/EC	EMC directive: Directive of the European Parliament and Council of December 15, 2004, which repeals directive 89/336/EEC, on the approximation of laws of the member states relating to electromagnetic compatibility
2006/42/EC	Machinery Directive: Directive of the European Parliament and Council of May 17, 2006, on machinery and amending Directive 95/16/EC (recast)
European standards	
EN ISO 3744	Acoustics - Determination of sound power levels and sound energy levels of noise sources using sound pressure – Engineering methods for an essentially free acoustic field over a reflecting plane
EN ISO 13849-1	Safety of machinery – safety-related parts of control systems; Part 1: General principles for design (ISO 13849-1: 2006)
EN 60146-1-1	Semiconductor converters – General requirements and line-commutated converters Part 1-1: Specification of basic requirements
EN 60204-1	Safety of machinery – Electrical equipment of machines; Part 1: General requirements
EN 60529	Degrees of protection provided by enclosures (IP Code)
EN 61508-1	Functional safety of electrical/electronic/programmable electronic safety-related systems Part 1: General requirements
EN 61800-2	Adjustable speed electrical power drive systems Part 2: General requirements – Rating specifications for low voltage adjustable frequency AC power drive systems
EN 61800-3	Adjustable speed electrical power drive systems Part 3: EMC - requirements and specific test methods
EN 61800-5-1	Adjustable speed electrical power drive systems Part 5: Safety requirements Main section 1: Electrical and thermal requirements
EN 61800-5-2	Adjustable speed electrical power drive systems Part 5-2: Safety requirements – Functional safety (IEC 61800-5-2: 2007)

SINAMICS S120 Cabinet Modules

Air-cooled units

Air-cooled units

Overview

Line Modules

Power is fed to the drive line-up via Line Modules, which generate a DC voltage from the line voltage and, therefore, supply energy to the Motor Modules connected to the DC link. They are suitable for connection to grounded TN/TT and non-grounded IT systems.

The Line Modules are connected to the line supply system via Line Connection Modules and are equipped as standard according to Category C3. Category C3 is part of the "second environment" (in accordance with EN 61800-3). The "second environment" constitutes locations outside residential areas or industrial sites which are supplied from the medium-voltage network via a separate transformer.

The range of Line Modules has power ratings from 132 kW to 900 kW (380 V to 480 V) and from 250 kW to 1500 kW (500 V to 690 V). Furthermore, up to four identical Line Modules can be connected in parallel in order to increase the power rating.

For a compact configuration, Line Connection Modules up to input currents of 3200 A are available. Two Line Modules can be operated in parallel on these Line Connection Modules.

The following types of Line Module are available:

- Basic Line Modules
- Smart Line Modules
- Active Line Modules

Basic Line Modules

Basic Line Modules are designed only for infeed operation, i.e. they are not capable of recovering energy to the line supply.

If regenerative energy is produced, e.g. when the drives brake, then it must be converted to heat by means of a Braking Module and a braking resistor.

When a Basic Line Module is used as the infeed, a line reactor appropriate to the supply conditions must be installed. Line reactors are generally required if two or more Basic Line Modules are operated in parallel on a common supply system in order to increase power.

For this reason, line reactors are installed in the appropriate Line Connection Module as standard.

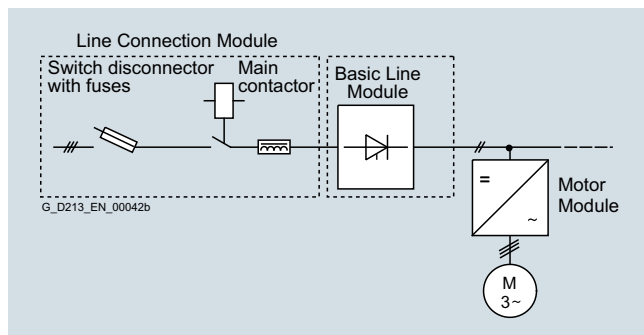

Line Connection Module with Basic Line Module ≤ 800 A

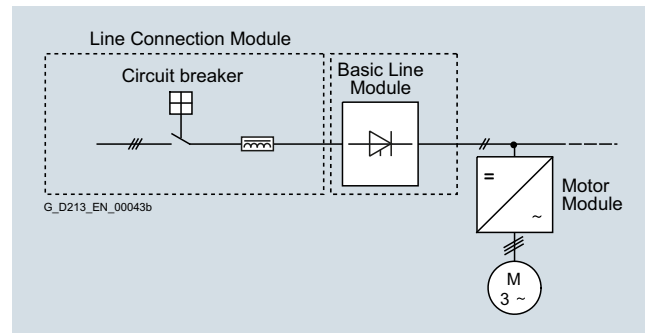

Line Connection Module with Basic Line Module > 800 A

If, for example, a converter transformer is used to connect to the line supply (12-pulse operation), it may be possible to omit line reactors (depending on the supply conditions on site) and they can be optionally deselected (option **L22** for a Line Connection Module combined with a Basic Line Module).

For a compact configuration, Line Connection Modules with input currents of up to 3200 A are available. Two Basic Line Modules can be operated in parallel on these Line Connection Modules. Versions with line-side fuses are available for parallel connections in order to provide selective protection of the individual Basic Line Modules.

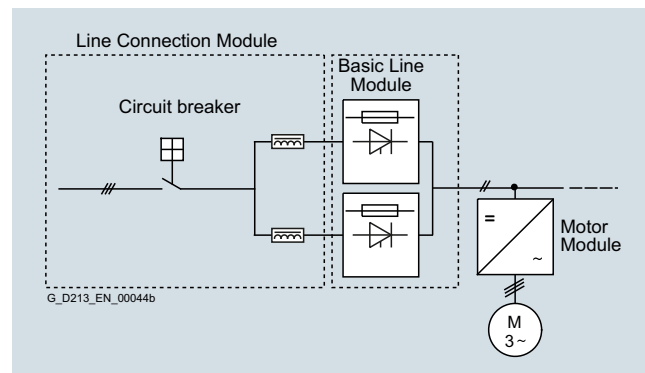

Line Connection Module with Basic Line Modules connected in parallel

Overview (continued)Smart Line Modules

Smart Line Modules can supply energy to the DC link and return regenerative energy to the supply system. Braking Modules and braking resistors are required only if the drives need to be decelerated in a controlled manner after a power failure (i.e. when energy cannot be recovered to the supply). When a Smart Line Module is used as the infeed, the necessary line reactor is included in the device as standard and can be optionally deselected (option **L22**).

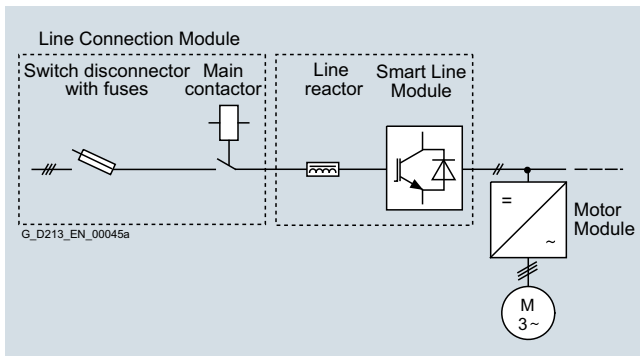
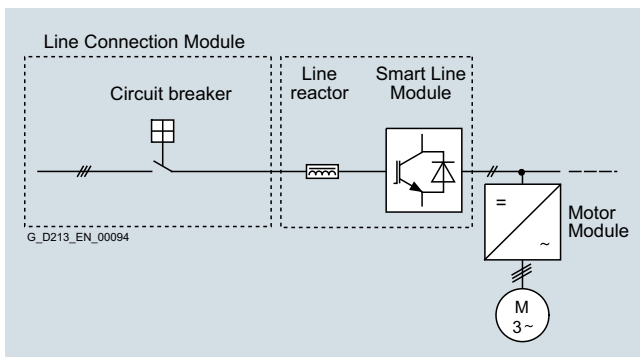
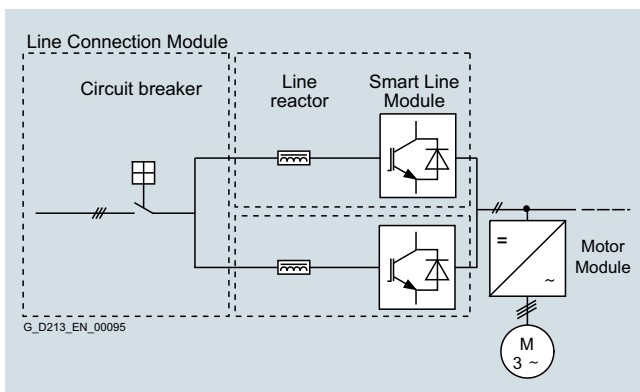
Line Connection Module with Smart Line Module ≤ 800 ALine Connection Module with Smart Line Module >800 A

Line Connection Module with Smart Line Modules connected in parallel

Active Line Modules

Active Line Modules can supply energy to the DC link and return regenerative energy to the supply system. Braking Modules and braking resistors are required only if the drives need to be decelerated in a controlled manner after a power failure (i.e. when energy cannot be recovered to the supply).

In contrast to Basic Line Modules and Smart Line Modules, however, Active Line Modules generate a regulated DC voltage which remains constant despite fluctuations in the line voltage. However, in this case, the line voltage must remain within the permissible tolerance range. Active Line Modules draw a virtually sinusoidal current from the supply which limits any harmful harmonics.

Active Line Modules must always be used in conjunction with an Active Interface Module. Active Interface Modules include the required pre-charging circuit for the Active Line Module in addition to a Clean Power Filter. For SINAMICS S120 Cabinet Modules, these two components are always regarded as a single unit.

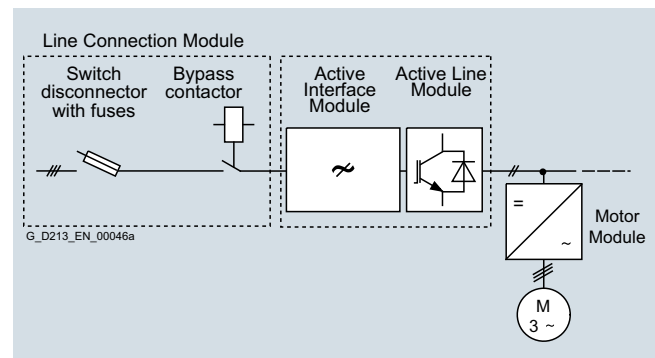
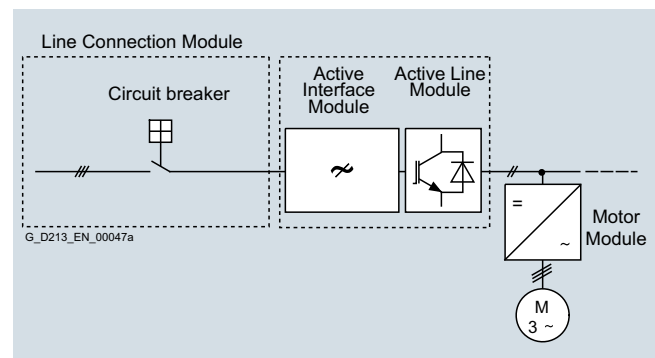
Line Connection Module with Active Interface Module and Active Line Module ≤ 800 A (example frame size HX + HI)Line Connection Module with Active Interface Module and Active Line Module >800 A

SINAMICS S120 Cabinet Modules

Air-cooled units

Air-cooled units

Overview (continued)

In the example, two units comprising an Active Interface Module and Active Line Module are connected in parallel to jointly supply the DC link.

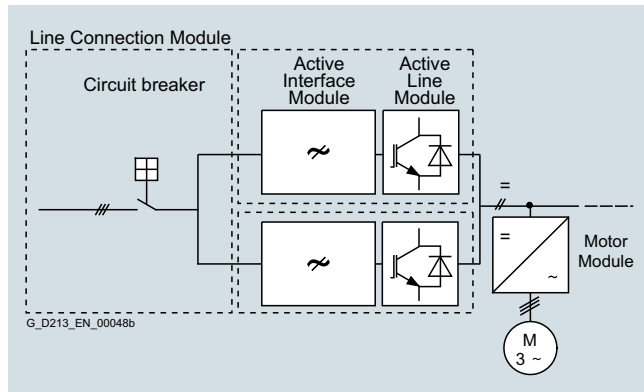

Line Connection Module with Active Interface Modules and Active Line Modules connected in parallel

DC link components

Braking Modules enable braking resistors to absorb the regenerative energy produced during drive deceleration, which is then converted into heat. Using a Braking Module and a braking resistor, it is possible to brake motors even when the power fails.

Braking Modules as a Line Module or Motor Module option

For lower braking powers, Braking Modules are available with continuous braking powers up to 50 kW. These Braking Modules are ordered as an option for the Line Modules and Motor Modules (order codes **L61/L64** (25 kW) or **L62/L65** (50 kW), refer to the [option description](#)).

Central Braking Modules

For higher continuous braking powers, separate Central Braking Modules are available. These modules are used centrally in the drive line-up. To increase the braking power, up to four Central Braking Modules can be connected in parallel.

Motor Modules

There are two different types of Motor Module available with the SINAMICS S120 Cabinet Modules drive system.

Booksize Base Cabinets with Booksize Cabinet Kits

Motor Modules at the low end of the power range from 4.8 kW to 71 kW (380 V to 480 V) can be implemented as Booksize Cabinet Kits installed in Booksize Base Cabinets.

Chassis Cabinets

Each Chassis Cabinet is fitted with one SINAMICS S120 Motor Module in chassis format and covers the power range from 75 kW to 1200 kW (380 V to 480 V or 500 V to 690 V). The power rating can be extended up to approx. 4500 kW by connecting up to four Motor Modules in the chassis format in parallel.

SINAMICS S120 Motor Modules in chassis format can also be used as a Braking Module (braking chopper) if a 3-phase braking resistor is connected instead of a motor.

[For more information on this topic, please refer to the SINAMICS Low Voltage Engineering Manual.](#)

Auxiliary Power Supply Modules

Auxiliary Power Supply Modules supply power to the auxiliary power supply system of the SINAMICS S120 Cabinet Modules.

Units connected to this auxiliary power supply system include the fans of the SINAMICS S120 devices installed in the Cabinet Modules. In addition, the auxiliary power supply system supplies the electronic modules with an external 24 V DC voltage. This is required when the DC link is not charged, for instance, in order to maintain PROFIBUS or PROFINET communication.

Technical specifications

General technical specifications

Electrical specifications			
Line voltages	380 ... 480 V 3 AC, ±10 % (-15 % <1 min) 500 ... 690 V 3 AC, ±10 % (-15 % <1 min)		
Line supply types	Grounded TN/TT systems and non-grounded IT systems		
Line frequency	47 ... 63 Hz		
Output frequency ¹⁾	0 ... 550 Hz		
• Control type Servo	0 ... 550 Hz		
• Control type Vector	0 ... 550 Hz		
• Control mode V/f	0 ... 550 Hz		
Line power factor Fundamental			
• Basic Line Module	>0.96		
• Smart Line Module	>0.96		
• Active Line Module	Adjustable (factory-set to $\cos \varphi = 1$)		
Efficiency			
• Basic Line Module	>99 %		
• Smart Line Module	>98.5 %		
• Active Line Module	>97.5 % (including Active Interface Module)		
• Motor Module	>98.5 %		
Overvoltage category	III to EN 61800-5-1		
Control method	Vector/Servo control with and without encoder or V/f control		
Fixed speeds	15 fixed speeds plus 1 minimum speed, parameterizable (in the default setting, 3 fixed setpoints plus 1 minimum speed are selectable using terminal block/PROFIBUS/PROFINET)		
Skippable speed ranges	4, parameterizable		
Setpoint resolution	0.001 rpm digital (14 bits + sign) 12 bits analog		
Braking operation	With Active Line Modules and Smart Line Modules, four-quadrant operation as standard (energy recovery). With Basic Line Modules, two-quadrant operation as standard, braking by means of an optional Braking Module, or alternatively by a Motor Module.		
Cabinet system			
Cabinet system	Rittal TS 8, doors with double-bit key, three-section base plates for cable entry		
Paint finish	RAL 7035 (indoor requirements)		
Mechanical specifications			
Degree of protection	IP20 (higher degrees of protection up to IP54 optional)		
Protection class	I acc. to EN 61800-5-1		
Touch protection	EN 50274/BGV A3 for the intended purpose		
Cooling method	Forced air cooling AF according to EN 60146		
Ambient conditions	Storage ²⁾	Transport ²⁾	Operation
Ambient temperature	-25 ... +55 °C	-25 ... +70 °C from <u>-40 °C</u> for 24 hours	0 ... +40 °C to +50 °C, see derating data
Relative humidity (condensation not permissible)	5 ... 95 % Class 1K4 to IEC 60721-3-1	5 ... 95 % at 40 °C Class 2K3 acc. to IEC 60721-3-2	5 ... 95 % Class 3K3 acc. to IEC 60721-3-3
Environmental class/harmful chemical substances	Class 1C2 acc. to EN 60721-3-1	Class 2C2 acc. to EN 60721-3-2	Class 3C2 acc. to EN 60721-3-3
Organic/biological influences	Class 1B1 acc. to EN 60721-3-1	Class 2B1 acc. to EN 60721-3-2	Class 3B1 acc. to EN 60721-3-3
Degree of pollution	2 acc. to EN 61800-5-1		
Installation altitude	Cabinet Modules chassis format: ≤2000 m above sea level - no derating; >2000 m, see characteristics/derating data For Booksize Cabinet Kit format Motor Modules as well as Central Braking Modules: ≤1000 m above sea level without derating, >1000 m, see characteristic curves/derating data		
Mechanical stability	Storage ²⁾	Transport ²⁾	Operation
Vibration load	Class 1M2 acc. to EN 60721-3-1		
• Deflection	1.5 mm at 5 ... 9 Hz		
• Acceleration	5 m/s ² at >9 ... 200 Hz		
Shock load	Class 1M2 acc. to EN 60721-3-1		
• Acceleration	40 m/s ² at 22 ms		
	Class 2M2 acc. to EN 60721-3-2	Class 2M2 acc. to EN 60721-3-2	Class 3M4 acc. to EN 60721-3-3
	3.1 mm at 5 ... 9 Hz	3.1 mm at 5 ... 9 Hz	0.075 mm at 10 ... 58 Hz
	10 m/s ² at >9 ... 200 Hz	10 m/s ² at >9 ... 200 Hz	9.8 m/s ² at >58 ... 200 Hz
	Class 2M2 acc. to EN 60721-3-2	Class 2M2 acc. to EN 60721-3-2	Class 3M4 acc. to EN 60721-3-3
	100 m/s ² at 11 ms	100 m/s ² at 11 ms	100 m/s ² at 11 ms
Compliance with standards			
Conformances/approvals, according to	CE (EMC Directive No. 2004/108/EC and Low Voltage Directive No. 2006/95/EC and Machinery Directive 2006/42/EC for functional safety)		
Radio interference suppression	SINAMICS drive converter systems are not designed for connection to the public grid (first environment). Radio interference suppression is compliant with the EMC product standard for variable-speed drives EN 61800-3, "Second environment" (industrial networks). EMC disturbances can occur when connected to the public power networks. However, if additional measures are taken (e.g. → line filter), it can also be operated in the "first environment".		

Deviations from the specified class are underlined.

¹⁾ Higher output frequencies available on request.

²⁾ In transport packaging.

SINAMICS S120 Cabinet Modules

Air-cooled units

Air-cooled units

Characteristic curves

Derating data for the chassis format

SINAMICS S120 Cabinet Modules and the associated system components are rated for an ambient temperature of 40 °C and installation altitudes up to 2000 m above sea level.

At ambient temperatures > 40 °C, the output current must be reduced. Ambient temperatures above 50 °C are not permissible.

At installation altitudes > 2000 m above sea level, it must be taken into account that the air pressure, and therefore air density, decreases as the height increases. As a consequence, the cooling efficiency and the insulation capacity of the air also decrease.

Due to the reduced cooling efficiency, it is necessary to both reduce the ambient temperature and lower heat loss in the Cabinet Module by reducing the output current, whereby ambient temperatures lower than 40 °C may be offset to compensate.

Current-derating factors for Cabinet Modules as a function of the ambient/air intake temperature, the installation altitude and the degree of protection.

The following table specifies the permissible output currents as a function of the installation altitude and ambient temperature for the various degrees of protection. (The permissible compensation between installation altitude and the ambient temperatures < 40 °C – air intake temperature at the entry to the Cabinet Module – has been taken into account in the specified values.)

The values apply under the precondition that it is guaranteed that the cooling air, as specified in the technical data, flows through the units as a result of the cabinet arrangement.

As additional measure for installation altitudes from 2000 m up to 5000 m, an isolating transformer is required in order to reduce transient overvoltages according to EN 60664-1.

[For additional information, please refer to the SINAMICS Low Voltage Engineering Manual.](#)

Degree of protection	Installation altitude above sea level m	Current derating factor (as a percentage of the rated current) for an ambient / air intake temperature of						
		20 °C	25 °C	30 °C	35 °C	40 °C	45 °C	50 °C
IP20, IP21, IP23, IP43	0 ... 2000						93.3 %	86.7 %
	2001 ... 2500					96.3 %		
	2501 ... 3000		100 %		98.7 %			
	3001 ... 3500				96.3 %			
	3501 ... 4000							
	4001 ... 4500		97.5 %					
	4501 ... 5000	98.2 %						
IP54	0 ... 2000					93.3 %	86.7 %	80 %
	2001 ... 2500					96.3 %	89.8 %	
	2501 ... 3000		100 %		98.7 %	92.5 %		
	3001 ... 3500				94.7 %			
	3501 ... 4000				96.3 %	90.7 %		
	4001 ... 4500		97.5 %	92.1 %				
	4501 ... 5000	93 %						

Characteristic curves (continued)

Current derating for SINAMICS S120 Motor Modules, chassis format as a function of the pulse frequency

To reduce motor noise or to increase output frequency, the pulse frequency can be increased relative to the factory setting (1.25 kHz or 2 kHz). When the pulse frequency is increased, the

derating factor of the output current must be taken into account. This derating factor must be applied to the currents specified in the technical specifications.

Further information is provided in the [SINAMICS Low Voltage Engineering Manual](#).

Derating factor of the output current as a function of the pulse frequency for units with a rated pulse frequency of 2 kHz

Motor Module in chassis format 6SL3720-...	Type rating at 400 V kW	Output current at 2 kHz A	Derating factor at pulse frequency				
			2.5 kHz	4 kHz	5 kHz	7.5 kHz	8 kHz
380 ... 480 V 3 AC							
1TE32-1AA3	110	210	95 %	82 %	74 %	54 %	50 %
1TE32-6AA3	132	260	95 %	83 %	74 %	54 %	50 %
1TE33-1AA3	160	310	97 %	88 %	78 %	54 %	50 %
1TE33-8AA3	200	380	96 %	87 %	77 %	54 %	50 %
1TE35-0AA3	250	490	94 %	78 %	71 %	53 %	50 %

Derating factor of the output current as a function of the pulse frequency for units with a rated pulse frequency of 1.25 kHz

Motor Module in chassis format 6SL3720-...	Type rating at 400 V or 690 V kW	Output current at 1.25 kHz A	Derating factor at pulse frequency				
			2 kHz	2.5 kHz	4 kHz	5 kHz	7.5 kHz
380 ... 480 V 3 AC							
1TE36-1AA3	315	605	83 %	72 %	64 %	60 %	40 %
1TE37-5AA3	400	745	83 %	72 %	64 %	60 %	40 %
1TE38-4AA3	450	840	87 %	79 %	64 %	55 %	40 %
1TE41-0AA3	560	985	92 %	87 %	70 %	60 %	50 %
1TE41-2AA3	710	1260	92 %	87 %	70 %	60 %	50 %
1TE41-4AA3	800	1405	97 %	95 %	74 %	60 %	50 %
500 ... 690 V 3 AC							
1TG28-5AA3	75	85	93 %	89 %	71 %	60 %	40 %
1TG31-0AA3	90	100	92 %	88 %	71 %	60 %	40 %
1TG31-2AA3	110	120	92 %	88 %	71 %	60 %	40 %
1TG31-5AA3	132	150	90 %	84 %	66 %	55 %	35 %
1TG31-8AA3	160	175	92 %	87 %	70 %	60 %	40 %
1TG32-2AA3	200	215	92 %	87 %	70 %	60 %	40 %
1TG32-6AA3	250	260	92 %	88 %	71 %	60 %	40 %
1TG33-3AA3	315	330	89 %	82 %	65 %	55 %	40 %
1TG34-1AA3	400	410	89 %	82 %	65 %	55 %	35 %
1TG34-7AA3	450	465	92 %	87 %	67 %	55 %	35 %
1TG35-8AA3	560	575	91 %	85 %	64 %	50 %	35 %
1TG37-4AA3	710	735	87 %	79 %	64 %	55 %	25 %
1TG38-1AA3	800	810	97 %	95 %	71 %	55 %	35 %
1TG38-8AA3	900	910	92 %	87 %	67 %	55 %	33 %
1TG41-0AA3	1000	1025	91 %	86 %	64 %	50 %	30 %
1TG41-3AA3	1200	1270	87 %	79 %	55 %	40 %	25 %

The following tables list the maximum achievable output frequency as a function of the pulse frequency:

Maximum output frequencies achieved by increasing the pulse frequency in Vector mode

Pulse frequency	Max. achievable output frequency
1.25 kHz	100 Hz
2 kHz	160 Hz
2.5 kHz	200 Hz
4 kHz	300 Hz

Maximum output frequencies achieved by increasing the pulse frequency in Servo mode

Pulse frequency	Max. achievable output frequency
2 kHz	300 Hz
4 kHz	300/550 Hz ¹⁾

¹⁾ Higher frequencies on request.

SINAMICS S120 Cabinet Modules

Air-cooled units

Air-cooled units

Characteristic curves (continued)

Derating data for devices in booksize format

SINAMICS S120 Cabinet Modules with power units in booksize format and the associated system components are rated for an ambient temperature of 40 °C and installation altitudes up to 1000 m above sea level. If SINAMICS S120 Cabinet Modules with power units in booksize format are operated at ambient temperatures higher than 40 °C and/or installation altitudes higher than 1000 m above sea level, then the corresponding derating functions must be taken into account as a function of the ambient temperature and/or the installation altitude. [These derating factors are different from the derating factors for the chassis format power units and are listed in Catalog PM 21.](#)

Overload capability

SINAMICS S120 Cabinet Modules have an overload reserve, e.g. to handle breakaway torques. If larger surge loads occur, this must be taken into account when configuring. For drives with overload requirements, the appropriate base load current must, therefore, be used as a basis for the required load.

Permissible overload assumes that the drive converter is operated at its base-load current before and after the overload occurs, based on a duty cycle duration of 300 s.

For temporary, periodic duty cycles with high variations of load within the duty cycle, the relevant sections of the SINAMICS Low Voltage Engineering Manual must be observed.

Motor Modules in chassis format

Motor Modules with power units in the chassis format can be configured on the basis of different base load currents.

The base-load current for a low overload I_L is the basis for a duty cycle of 110 % for 60 s or 150 % for 10 s.

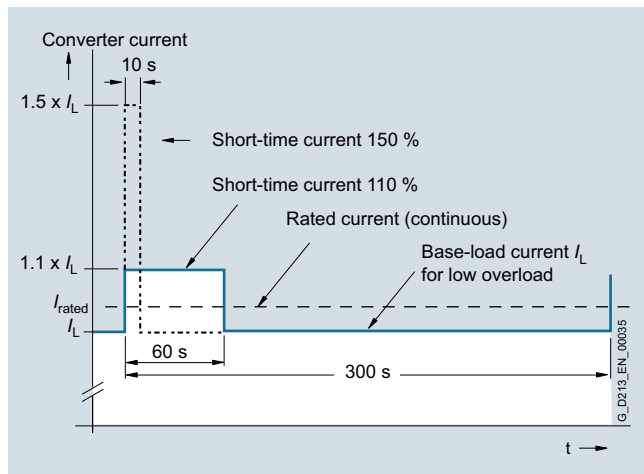

Low overload

The base-load current I_H for a high overload is based on a load cycle of 150 % for 60 s or 160 % for 10 s.

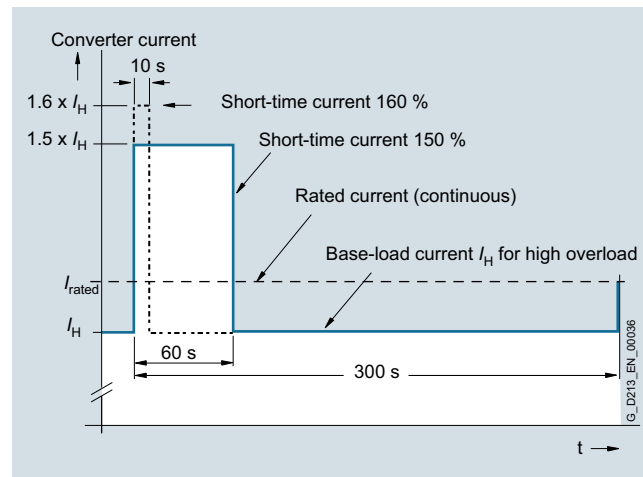

High overload

Motor Modules in booksize format

Motor Modules with power units in the booksize format have the following overload capabilities:

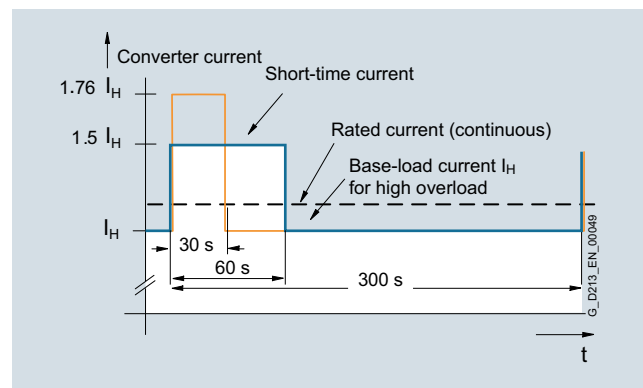

High overload

Line Modules in chassis format

The base-load current for a high overload I_{HDC} is the basis for a duty cycle of 150 % for 60 s or I_{maxDC} for 5 s.

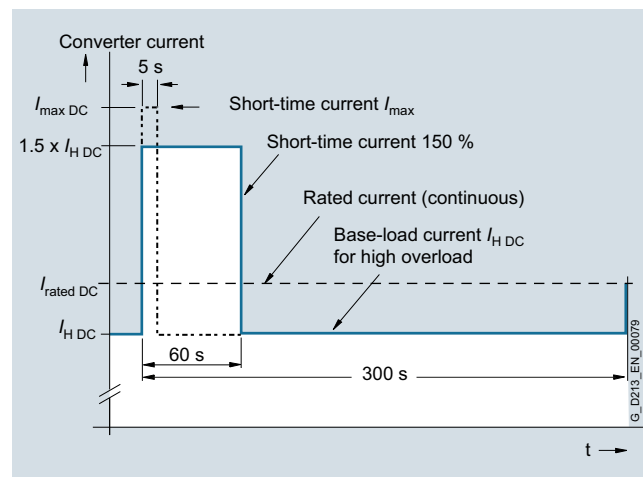

Overview



Line Connection Modules (LCM) contain the line-side infeed with main circuit breaker and fuse switch disconnecter or circuit breaker and provide the connection between the plant power system and the Line Modules.

Line Connection Modules are available for the following voltages and currents:

Line voltage	Rated infeed/ regenerative feedback current
380 ... 480 V 3 AC	250 ... 3200 A
500 ... 690 V 3 AC	280 ... 3200 A

Design

Different versions exist depending on the input current:

- Units ≤ 800 A are equipped with a main switch with a fuse switch disconnecter
- Units > 800 A are equipped with a fixed-mounted circuit breaker (draw-out circuit breaker is available as option)

When Line Connection Modules are ordered, the type of Line Module used must be specified:

- For Basic Line Modules: Option **L43**
- For Smart Line Modules: Option **L44**
- For Active Line Modules: Option **L42**

When using a Basic Line Module, a reactor is included in the scope of delivery of the Line Connection Module, and when required, can be deselected (option **L22**).

For additional information, please refer to the [SINAMICS Low Voltage Engineering Manual](#).

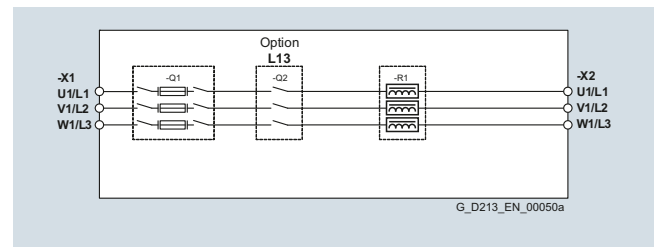

Connection example of a Line Connection Module for units ≤ 800 A to connect to Basic Line Modules, option **L43**, option main contactor, order code **L13**

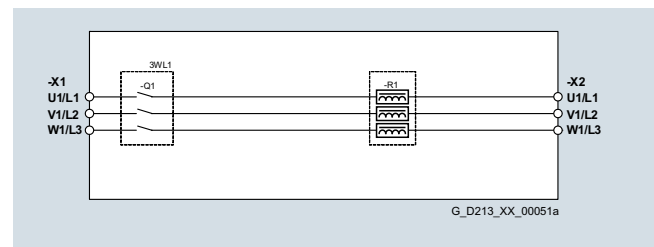

Connection example of a Line Connection Module for units > 800 A, < 2000 A to connect to the Basic Line Modules, option **L43**

For input currents ≥ 2000 A, additional options are available:

- Grounding switch upstream of main circuit breaker: Option **L46**
- Current transformer upstream of main circuit breaker: Option **L41**
- Grounding switch downstream of main circuit breaker: Option **L47**

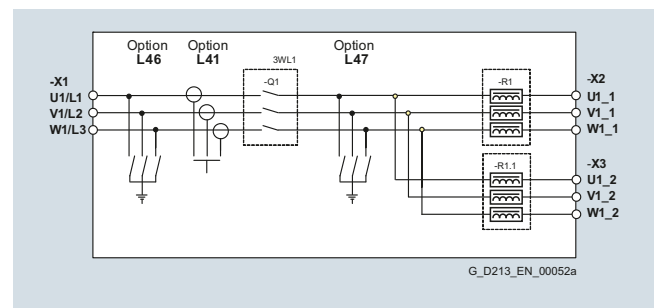

Connection example of a Line Connection Module ≥ 2000 A

SINAMICS S120 Cabinet Modules

Air-cooled units

Line Connection Modules

Design (continued)

When Basic Line Modules that are fed via a common Line Connection Module are connected in parallel, line reactors are generally required. These are installed in the Line Connection Module.

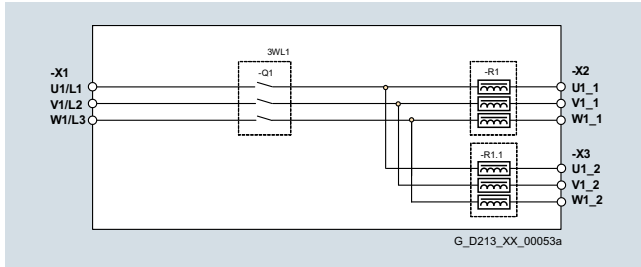

Connection example: Line Connection Module ≥ 2000 A for connection to Basic Line Modules, option **L43**

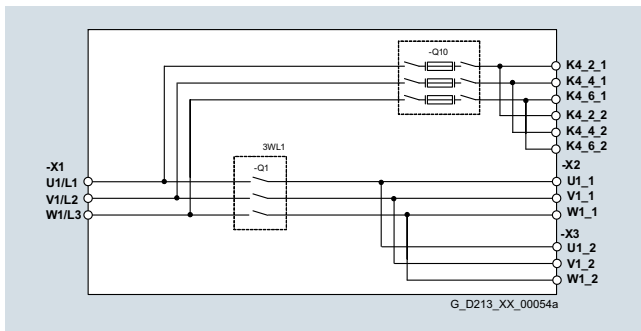

Connection example: Line Connection Module ≥ 2000 A for connection to Active Line Modules in parallel connection, option **L42**

Selection and ordering data

Rated infeed/ regenerative feedback current ¹⁾ A	Line Connection Module Article No.
Line voltage 380 ... 480 V 3 AC	
250	6SL3700-0LE32-5AA3
380	6SL3700-0LE34-0AA3
600	6SL3700-0LE36-3AA3
770	6SL3700-0LE38-0AA3
1000	6SL3700-0LE41-0AA3
1250	6SL3700-0LE41-3AA3
1600	6SL3700-0LE41-6AA3
2000	6SL3700-0LE42-0AA3
2000	6SL3700-0LE42-0BA3
2500	6SL3700-0LE42-5BA3
3200	6SL3700-0LE43-2BA3
Line voltage 500 ... 690 V 3 AC	
280	6SL3700-0LG32-8AA3
380	6SL3700-0LG34-0AA3
600	6SL3700-0LG36-3AA3
770	6SL3700-0LG38-0AA3
1000	6SL3700-0LG41-0AA3
1250	6SL3700-0LG41-3AA3
1600	6SL3700-0LG41-6AA3
2000	6SL3700-0LG42-0BA3
2500	6SL3700-0LG42-5BA3
3200	6SL3700-0LG43-2BA3

Note:

When ordering Line Connection Modules, the option order code must be appended to the article number to indicate whether the Line Connection Module is to be connected to a Basic Line Module (option **L43**), to a Smart Line Module (option **L44**) or to an Active Line Module (option **L42**).

This information is required to ensure that the Line Connection Module is correctly equipped at the factory. This particularly applies to the busbar connection at the 3-phase end (3 AC), to any pre-charging circuits required and to the specified line reactors for Basic Line Modules.

When Cabinet Modules are selected and combined, the specified equipping and preparation of the Line Connection Modules is performed at the factory in accordance with the assignment table in the Integration section. For all other combinations deviating from this, this is not the case. In such cases, the 3-AC busbar connections will have to be engineered and installed on site.

¹⁾ The current values stated are based on an ambient temperature (air intake temperature) of 40 °C.

Integration

Line Connection Module		Basic Line Module		Smart Line Module		Active Line Module	
Rated infeed/ regenerative feed- back current ¹⁾		Rated input current		Rated infeed/ regenerative feed- back current		Rated infeed/ regenerative feed- back current	
A		A		A		A	
Line voltage 380 ... 480 V 3 AC							
250	6SL3700-0LE32-5AA3	–	–	–	–	210	6SL3730-7TE32-1BA3
380	6SL3700-0LE34-0AA3	–	–	–	–	260	6SL3730-7TE32-6BA3
600	6SL3700-0LE36-3AA3	365	6SL3730-1TE34-2AA3	463	6SL3730-6TE35-5AA3	380	6SL3730-7TE33-8BA3
		460	6SL3730-1TE35-3AA3			490	6SL3730-7TE35-0BA3
770	6SL3700-0LE38-0AA3	710	6SL3730-1TE38-2AA3	614	6SL3730-6TE37-3AA3	605	6SL3730-7TE36-1BA3
1000	6SL3700-0LE41-0AA3	–	–	883	6SL3730-6TE41-1AA3	840	6SL3730-7TE38-4BA3
1250	6SL3700-0LE41-3AA3	1010	6SL3730-1TE41-2AA3	1093	6SL3730-6TE41-3AA3	985	6SL3730-7TE41-0BA3
1600	6SL3700-0LE41-6AA3	1265	6SL3730-1TE41-5AA3	1430	6SL3730-6TE41-7AA3	1405	6SL3730-7TE41-4BA3
2000	6SL3700-0LE42-0AA3	1630	6SL3730-1TE41-8AA3	–	–	–	–
2000	6SL3700-0LE42-0BA3	2 × 935	<i>6SL3730-1TE41-2BA3</i>	2 × 817	<i>6SL3730-6TE41-1BA3</i>	2 × 936	<i>6SL3730-7TE41-0BA3</i>
			<i>6SL3730-1TE41-2BC3</i>		<i>6SL3730-6TE41-1BC3</i>		<i>6SL3730-7TE41-0BC3</i>
2500	6SL3700-0LE42-5BA3	2 × 1170	<i>6SL3730-1TE41-5BA3</i>	2 × 1011	<i>6SL3730-6TE41-3BA3</i>	–	–
			<i>6SL3730-1TE41-5BC3</i>		<i>6SL3730-6TE41-3BC3</i>		
3200	6SL3700-0LE43-2BA3	2 × 1508	<i>6SL3730-1TE41-8BA3</i>	2 × 1323	<i>6SL3730-6TE41-7BA3</i>	2 × 1335	<i>6SL3730-7TE41-4BA3</i>
			<i>6SL3730-1TE41-8BC3</i>		<i>6SL3730-6TE41-7BC3</i>		<i>6SL3730-7TE41-4BC3</i>
Line voltage 500 ... 690 V 3 AC							
280	6SL3700-0LG32-8AA3	260	6SL3730-1TG33-0AA3	–	–	–	–
380	6SL3700-0LG34-0AA3	375	6SL3730-1TG34-3AA3	–	–	–	–
600	6SL3700-0LG36-3AA3	575	6SL3730-1TG36-8AA3	463	6SL3730-6TG35-5AA3	575	6SL3730-7TG35-8BA3
770	6SL3700-0LG38-0AA3	–	–	757	6SL3730-6TG38-8AA3	735	6SL3730-7TG37-4BA3
1000	6SL3700-0LG41-0AA3	925	6SL3730-1TG41-1AA3	–	–	–	–
1250	6SL3700-0LG41-3AA3	1180	6SL3730-1TG41-4AA3	1009	6SL3730-6TG41-2AA3	1025	6SL3730-7TG41-0BA3
1600	6SL3700-0LG41-6AA3	1580	6SL3730-1TG41-8AA3	1430	6SL3730-6TG41-7AA3	1270	6SL3730-7TG41-3BA3
2000	6SL3700-0LG42-0BA3	2 × 855	<i>6SL3730-1TG41-1BA3</i>	2 × 700	<i>6SL3730-6TG38-8BA3</i>	2 × 698	<i>6SL3730-7TG37-4BA3</i>
			<i>6SL3730-1TG41-1BC3</i>		<i>6SL3730-6TG38-8BC3</i>		<i>6SL3730-7TG37-4BC3</i>
2500	6SL3700-0LG42-5BA3	2 × 1092	<i>6SL3730-1TG41-4BA3</i>	2 × 934	<i>6SL3730-6TG41-2BA3</i>	2 × 974	<i>6SL3730-7TG41-0BA3</i>
			<i>6SL3730-1TG41-4BC3</i>		<i>6SL3730-6TG41-2BC3</i>		<i>6SL3730-7TG41-0BC3</i>
3200	6SL3700-0LG43-2BA3	2 × 1462	<i>6SL3730-1TG41-8BA3</i>	2 × 1323	<i>6SL3730-6TG41-7BA3</i>	–	–
			<i>6SL3730-1TG41-8BC3</i>		<i>6SL3730-6TG41-7BC3</i>		
Entries in italics:	<p>Parallel circuit of two Line Modules connected to a Line Connection Module.</p> <p>The required derating factors listed below are already included in the current values given above:</p> <ul style="list-style-type: none"> • 7.5% for Basic Line Modules • 7.5% for Smart Line Modules • 5% for Active Line Modules 						

¹⁾ The current values stated are based on an ambient temperature (air intake temperature) of 40 °C.

SINAMICS S120 Cabinet Modules

Air-cooled units

Line Connection Modules

Technical specifications

Line voltage 380 ... 480 V 3 AC	Line Connection Modules						
		6SL3700-0LE32-5AA3	6SL3700-0LE34-0AA3	6SL3700-0LE36-3AA3	6SL3700-0LE38-0AA3	6SL3700-0LE41-0AA3	6SL3700-0LE41-3AA3
Infeed/regenerative feedback current							
• Rated current I_{rated}	A	250	380	600	770	1000	1250
Current demand							
• Fan power supply 230 V AC	A	–	–	–	–	1.07	1.07
• 230 V AC ¹⁾							
- Inrush current	A	3.6	3.6	3.6	10.8	0.5	0.5
- Holding current	A	0.04	0.04	0.04	0.12	0.06	0.06
Power loss, max. ²⁾							
• At 50 Hz 400 V							
- Option L42/L44	kW	0.115	0.19	0.31	0.39	0.18	0.29
- Option L43	kW	–	–	0.675	0.74	–	0.787
• At 60 Hz 460 V							
- Option L42/L44	kW	0.115	0.19	0.31	0.39	0.18	0.29
- Option L43	kW	–	–	0.675	0.74	–	0.787
Cooling air requirement ³⁾	m ³ /s	–	–	–	–	0.36	0.36
Sound pressure level L_{pA} (1 m) at 50/60 Hz	dB	–	–	–	–	68/70	68/70
Line supply connection L1, L2, L3		2/M12	2/M12	2/M12	2/M12	5/M12 + 4/M16	5/M12 + 4/M16
• Conductor cross section, max. (IEC)	mm ²	2 × 150	2 × 150	4 × 240	8 × 240	8 × 240	8 × 240
PE/GND connection		PE bar	PE bar	PE bar	PE bar	PE bar	PE bar
• Busbar cross-section	mm ²	600	600	600	600	600	600
• Conductor cross section, max. (IEC)	mm ²	240	240	240	240	240	240
Degree of protection		IP20	IP20	IP20	IP20	IP20	IP20
Dimensions							
• Width	mm	400	400	600	600	600	600
• Height ⁴⁾	mm	2200	2200	2200	2200	2200	2200
• Depth	mm	600	600	600	600	600	600
Weight, approx.							
• Option L42/L44	kg	210	230	310	340	450	470
• Option L43	kg	–	–	360	420	–	570
Frame size		FL	FL	GL	HL	JL	JL
Short-circuit current rating according to IEC	kA	50	50	50	50	50	50
Minimum short-circuit current ⁵⁾	A	3000	3000	8000	12000	2000	2500

¹⁾ Current demand of contactors/circuit breakers and fans with degree of protection IP23, IP43, IP54 (in combination with Basic Line Modules).

²⁾ The specified power loss represents the maximum value at 100% utilization. The value is lower under normal operating conditions.

³⁾ For IP23, IP43 or IP54 degree of protection only (in combination with Basic Line Modules).

⁴⁾ The cabinet height increases by 250 mm with degree of protection IP21, and by 400 mm with degrees of protection IP23, IP43 and IP54.

⁵⁾ Current required to ensure reliable tripping of installed protective devices.

Technical specifications (continued)

Line voltage 380 ... 480 V 3 AC	Line Connection Modules					
		6SL3700-OLE41-6AA3	6SL3700-OLE42-0AA3	6SL3700-OLE42-0BA3	6SL3700-OLE42-5BA3	6SL3700-OLE43-2BA3
		Prepared for connection to Line Modules connected in parallel				
Infeed/regenerative feedback current						
• Rated current $I_{rated I}$	A	1600	2000	2000	2500	3200
Current demand						
• Fan power supply 230 V AC	A	1.07	2.14	2.14	2.14	2.14
• 230 V AC ¹⁾						
- Inrush current	A	0.5	0.5	0.5	0.5	0.5
- Holding current	A	0.06	0.06	0.06	0.06	0.04
Power loss, max. ²⁾						
• At 50 Hz 400 V						
- Option L42/L44	kW	0.41	0.6	0.6	0.95	0.95
- Option L43	kW	1.186	1.366	1.594	2.502	2.482
• At 60 Hz 460 V						
- Option L42/L44	kW	0.41	0.6	0.6	0.95	0.95
- Option L43	kW	1.186	1.366	1.594	2.502	2.482
Cooling air requirement ³⁾	m ³ /s	0.36	0.72	0.72	0.72	0.72
Sound pressure level L_{pA} (1 m) at 50/60 Hz	dB	68/70	70/72	70/72	70/72	70/72
Line supply connection L1, L2, L3		5/M12 + 4/M16	5/M12 + 4/M16	5/M12 + 4/M16	5/M12 + 4/M16	5/M12 + 4/M16
• Conductor cross section, max. (IEC)	mm ²	8 × 240	10 × 240	10 × 240	10 × 240	10 × 300
PE/GND connection		PE bar	PE bar	PE bar	PE bar	PE bar
• Busbar cross-section	mm ²	600	600	600	600	600
• Conductor cross section, max. (IEC)	mm ²	240	240	240	240	240
Degree of protection		IP20	IP20	IP20	IP20	IP20
Dimensions						
• Width	mm	600	1000	1000	1000	1000
• Height ⁴⁾	mm	2200	2200	2200	2200	2200
• Depth	mm	600	600	600	600	600
Weight, approx.						
• Option L42/L44	kg	490	600	620	620	720
• Option L43	kg	650	760	820	900	1000
Frame size		JL	KL	KL	KL	LL
Short-circuit current rating according to IEC	kA	100	100	100	100	100
Minimum short-circuit current ⁵⁾	A	3200	4000	4000	5000	6400

¹⁾ Current demand of contactors/circuit breakers and fans with degree of protection IP23, IP43, IP54 (in combination with Basic Line Modules).

²⁾ The specified power loss represents the maximum value at 100% utilization. The value is lower under normal operating conditions.

³⁾ For IP23, IP43 or IP54 degree of protection only (in combination with Basic Line Modules).

⁴⁾ The cabinet height increases by 250 mm with degree of protection IP21, and by 400 mm with degrees of protection IP23, IP43 and IP54.

⁵⁾ Current required to ensure reliable tripping of installed protective devices.

SINAMICS S120 Cabinet Modules

Air-cooled units

Line Connection Modules

Technical specifications (continued)

Line voltage 500 ... 690 V 3 AC	Line Connection Modules					
	6SL3700-OLG32-8AA3	6SL3700-OLG34-0AA3	6SL3700-OLG36-3AA3	6SL3700-OLG38-0AA3	6SL3700-OLG41-0AA3	
Infeed/regenerative feedback current						
• Rated current I_{rated}	A	280	380	600	770	1000
Current demand						
• Fan power supply 230 V AC	A	–	–	–	–	1.07
• 230 V AC ¹⁾						
- Inrush current	A	3.6	3.6	3.6	10.8	0.5
- Holding current	A	0.04	0.04	0.04	0.12	0.06
Power loss, max. ²⁾						
• At 50 Hz 500/690 V						
- Option L42/L44	kW	0.125	0.19	0.31	0.39	0.18
- Option L43	kW	0.402	0.668	0.794	–	0.963
• At 60 Hz 575 V						
- Option L42/L44	kW	0.125	0.19	0.31	0.39	0.18
- Option L43	kW	0.402	0.668	0.794	–	0.963
Cooling air requirement ³⁾	m ³ /s	–	–	–	–	0.36
Sound pressure level L_{pA} (1 m) at 50/60 Hz	dB	–	–	–	–	68/70
Line supply connection L1, L2, L3		2/M12	2/M12	2/M12	2/M12	5/M12 + 4/M16
• Conductor cross section, max. (IEC)	mm ²	2 × 150	2 × 150	4 × 240	8 × 240	8 × 240
PE/GND connection		PE bar	PE bar	PE bar	PE bar	PE bar
• Busbar cross-section	mm ²	600	600	600	600	600
• Conductor cross section, max. (IEC)	mm ²	240	240	240	240	240
Degree of protection		IP20	IP20	IP20	IP20	IP20
Dimensions						
• Width	mm	400	600	600	600	600
• Height ⁴⁾	mm	2200	2200	2200	2200	2200
• Depth	mm	600	600	600	600	600
Weight, approx.						
• Option L42/L44	kg	220	230	310	340	450
• Option L43	kg	260	310	400	–	650
Frame size		FL	FL	GL	HL	JL
Short-circuit current rating according to IEC	kA	50	50	50	50	85
Minimum short-circuit current ⁵⁾	A	3200	3500	9000	15000	2000

¹⁾ Current demand of contactors/circuit breakers and fans with degree of protection IP23, IP43, IP54 (in combination with Basic Line Modules).

²⁾ The specified power loss represents the maximum value at 100% utilization. The value is lower under normal operating conditions.

³⁾ For IP23, IP43 or IP54 degree of protection only (in combination with Basic Line Modules).

⁴⁾ The cabinet height increases by 250 mm with degree of protection IP21, and by 400 mm with degrees of protection IP23, IP43 and IP54.

⁵⁾ Current required to ensure reliable tripping of installed protective devices.

Technical specifications (continued)

Line voltage 500 ... 690 V 3 AC	Line Connection Modules					
		6SL3700- OLG41-3AA3	6SL3700- OLG41-6AA3	6SL3700- OLG42-0BA3	6SL3700- OLG42-5BA3	6SL3700- OLG43-2BA3
		<i>Prepared for connection to Line Modules connected in parallel</i>				
Infeed/regenerative feedback current						
• Rated current $I_{rated I}$	A	1250	1600	2000	2500	3200
Current demand						
• Fan power supply 230 V AC	A	1.07	1.07	2.14	2.14	2.14
• 230 V AC ¹⁾						
- Inrush current	A	0.5	0.5	0.5	0.5	0.5
- Holding current	A	0.06	0.06	0.06	0.06	0.06
Power loss, max. ²⁾						
• At 50 Hz 500/690 V						
- Option L42/L44	kW	0.29	0.41	0.6	0.6	0.95
- Option L43	kW	1.073	1.387	2.166	2.166	2.894
• At 60 Hz 575 V						
- Option L42/L44	kW	0.29	0.41	0.6	0.6	0.95
- Option L43	kW	1.073	1.387	2.166	2.166	2.894
Cooling air requirement ³⁾	m ³ /s	0.36	0.36	0.72	0.72	0.72
Sound pressure level L_{pA} (1 m) at 50/60 Hz	dB	68/70	68/70	70/72	70/72	70/72
Line supply connection L1, L2, L3		5/M12 + 4/M16	5/M12 + 4/M16	5/M12 + 4/M16	5/M12 + 4/M16	5/M12 + 4/M16
• Conductor cross section, max. (IEC)	mm ²	8 × 240	8 × 240	10 × 240	10 × 240	10 × 300
PE/GND connection		PE bar	PE bar	PE bar	PE bar	PE bar
• Busbar cross-section	mm ²	600	600	600	600	600
• Conductor cross section, max. (IEC)	mm ²	240	240	240	240	240
Degree of protection		IP20	IP20	IP20	IP20	IP20
Dimensions						
• Width	mm	600	600	1000	1000	1000
• Height ⁴⁾	mm	2200	2200	2200	2200	2200
• Depth	mm	600	600	600	600	600
Weight, approx.						
• Option L42/L44	kg	470	490	600	620	720
• Option L43	kg	670	680	980	1000	1080
Frame size		JL	JL	KL	KL	LL
Short-circuit current rating according to IEC	kA	85	85	85	85	85
Minimum short-circuit current ⁵⁾	A	2500	3200	4000	5000	6400

¹⁾ Current demand of contactors/circuit breakers and fans with degree of protection IP23, IP43, IP54 (in combination with Basic Line Modules).

²⁾ The specified power loss represents the maximum value at 100% utilization. The value is lower under normal operating conditions.

³⁾ For IP23, IP43 or IP54 degree of protection only (in combination with Basic Line Modules).

⁴⁾ The cabinet height increases by 250 mm with degree of protection IP21, and by 400 mm with degrees of protection IP23, IP43 and IP54.

⁵⁾ Current required to ensure reliable tripping of installed protective devices.

SINAMICS S120 Cabinet Modules

Air-cooled units

Basic Line Modules

Overview



Basic Line Modules (BLM) are compact line infeeds for two-quadrant operation, i.e. no regenerative feedback.

They are used when energy need not be fed back into the network.

If regenerative conditions occur in the drive line-up, Braking Modules must be used because they convert the excess energy into heat in braking resistors.

Basic Line Modules are suitable for connection to grounded TN/TT and non-grounded IT systems. The following voltages and power ratings are available:

Line voltage	Rated power
380 ... 480 V 3 AC	200 ... 900 kW
500 ... 690 V 3 AC	250 ... 1500 kW

The power ratings can be increased by connecting up to four identical Basic Line Modules in parallel.

For an infeed with the Basic Line Modules, depending on the line short-circuit power, a line reactor should be provided at the connection point. This reactor is available as standard in the Line Connection Module. However, it can be omitted if it is not required (option **L22**).

For additional information, please refer to the SINAMICS Low Voltage Engineering Manual.

Design

The Basic Line Modules are available in different frame sizes.

With frame sizes FB and GB, a fully controlled thyristor bridge is used to pre-charge the Basic Line Modules and connected Motor Modules. The thyristors normally operate with a trigger delay angle of 0°.

Basic Line Modules, frame size GD for 900 kW (400 V) or 1500 kW (690 V) include a diode bridge, and the DC link is pre-charged via a separate line-side pre-charging device that is located in the Line Connection Module (option **L43**, Line Connection Module for Basic Line Module).

Parallel connection of Basic Line Modules to increase power rating

Line Modules can be connected in parallel (relative to the line supply) in two ways for the purpose of creating drive line-ups with a higher power rating.

Two Basic Line Modules supplied with power via two separate Line Connection Modules

With this arrangement, each Basic Line Module is supplied via a Line Connection Module and the Basic Line Modules are protected by fuses or circuit breakers (at $I > 800$ A) in the Line Connection Module and is mechanically coupled. It is not necessary to mechanically directly couple both "groups" comprising Line Connection Module and Basic Line Module. Other modules can also be inserted in between.

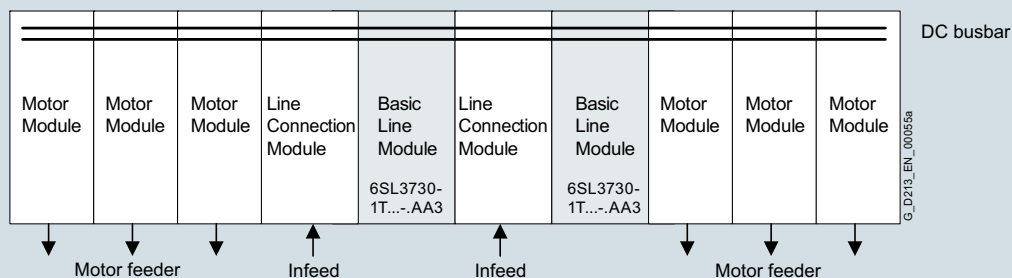

Design (continued)

Two Basic Line Modules supplied with power via a single Line Connection Module

Basic Line Modules are available that can be operated on a single Line Connection Module. These can be connected to the left and right of the Line Connection Module. The power connections on the Basic Line Module on the left of the Line Connection Module are a mirror image (article no. with "C" in the next to last position, example: 6SL3730-1T.41-**BC3**), which results in a very compact design for the line infeed.

For additional information, please refer to the SINAMICS Low Voltage Engineering Manual.

These module versions feature integrated line-side fuses which are required because the circuit breaker in the Line Connection Module is not capable of providing selective protection for the Basic Line Modules. They are therefore 200 mm wider in each case than version 6SL3730-1T...-AA3.

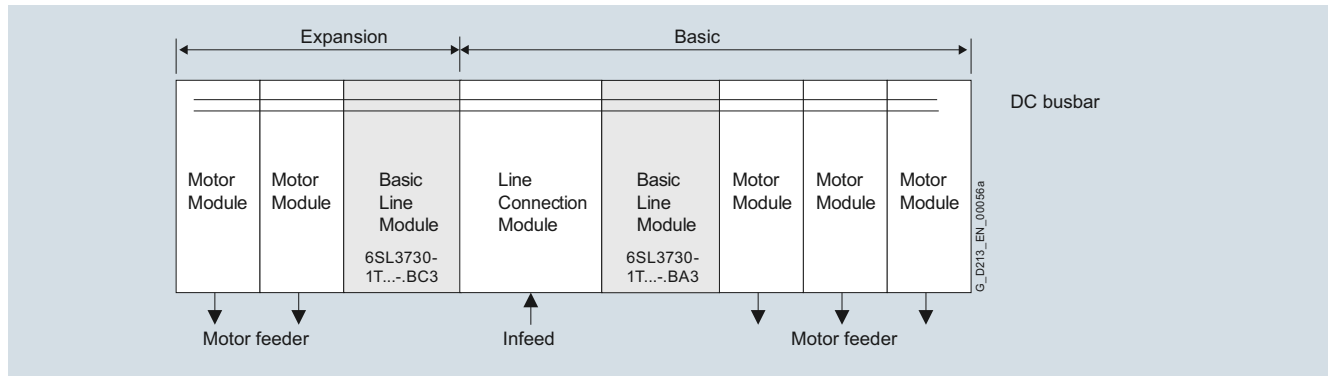

Note:

If the Basic Line Modules are supplied with power via the same circuit breaker, line-side fuses are provided to ensure selective individual protection of the modules. This arrangement increases the cabinet width by 200 mm (dimension data in selection tables includes extra width).

Please note that only Basic Line Modules with exactly the same output rating may be connected in parallel. The potential for imbalances in current distribution means that current derating of

7.5 % applies and this must be taken into account when the modules are dimensioned.

A connection of the Basic Line Modules connected in parallel using DRIVE-CLiQ must be taken into consideration.

For additional information, please refer to the SINAMICS Low Voltage Engineering Manual.

Selection and ordering data

Rated power at 400 V	Rated DC link current	Note for a parallel connection	Basic Line Module
kW	A	Mounting onto a Line Connection Module	Article No.
Line voltage 380 ... 480 V 3 AC (DC link voltage 510 ... 650 V DC)			
200	420	–	6SL3730-1TE34-2AA3
250	530	–	6SL3730-1TE35-3AA3
400	820	–	6SL3730-1TE38-2AA3
560	1200	–	6SL3730-1TE41-2AA3
		Right	6SL3730-1TE41-2BA3
		Left	6SL3730-1TE41-2BC3
710	1500	–	6SL3730-1TE41-5AA3
		Right	6SL3730-1TE41-5BA3
		Left	6SL3730-1TE41-5BC3
900	1880	–	6SL3730-1TE41-8AA3
		Right	6SL3730-1TE41-8BA3
		Left	6SL3730-1TE41-8BC3

Rated power at 690 V	Rated DC link current	Note for a parallel connection	Basic Line Module
kW	A	Mounting onto a Line Connection Module	Article No.
Line voltage 500 ... 690 V 3 AC (DC link voltage 675 ... 930 V DC)			
250	300	–	6SL3730-1TG33-0AA3
355	430	–	6SL3730-1TG34-3AA3
500	680	–	6SL3730-1TG36-8AA3
900	1100	–	6SL3730-1TG41-1AA3
		Right	6SL3730-1TG41-1BA3
		Left	6SL3730-1TG41-1BC3
1100	1400	–	6SL3730-1TG41-4AA3
		Right	6SL3730-1TG41-4BA3
		Left	6SL3730-1TG41-4BC3
1500	1880	–	6SL3730-1TG41-8AA3
		Right	6SL3730-1TG41-8BA3
		Left	6SL3730-1TG41-8BC3

SINAMICS S120 Cabinet Modules

Air-cooled units

Basic Line Modules

Integration

4

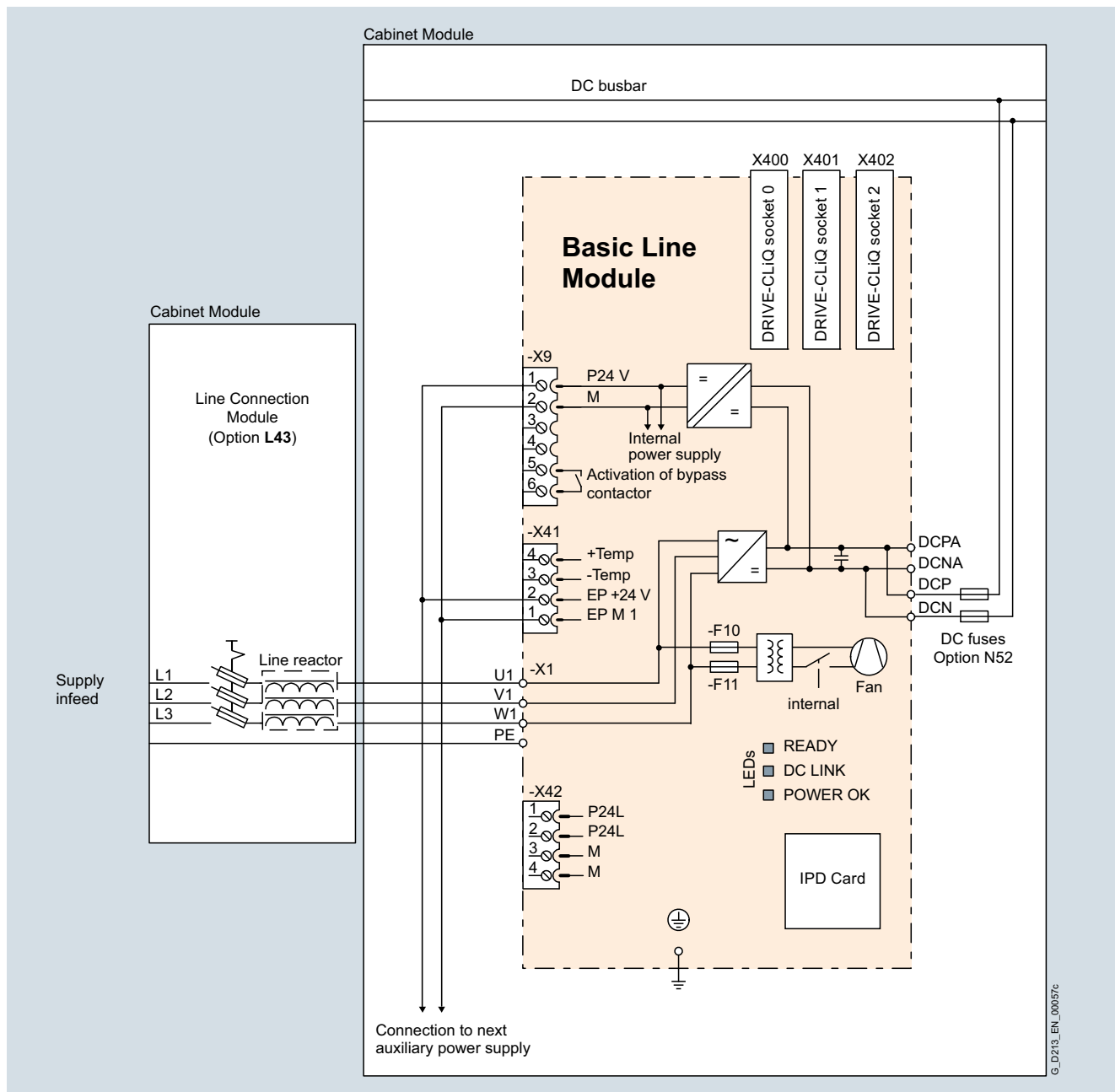

Connection example of a Basic Line Module

G_D213_EN_00057c

Technical specifications

Line voltage 380 ... 480 V 3 AC		Basic Line Modules					
		6SL3730-1TE34-2AA3	6SL3730-1TE35-3AA3	6SL3730-1TE38-2AA3	6SL3730-1TE41-2AA3	6SL3730-1TE41-5AA3	6SL3730-1TE41-8AA3
For a parallel circuit configuration, mounted to the <u>right</u> of the Line Connection Module					6SL3730-1TE41-2BA3	6SL3730-1TE41-5BA3	6SL3730-1TE41-8BA3
For a parallel circuit configuration, mounted to the <u>left</u> of the Line Connection Module					6SL3730-1TE41-2BC3	6SL3730-1TE41-5BC3	6SL3730-1TE41-8BC3
Rated power							
• At $I_{\text{rated DC}}$ (50 Hz 400 V)	kW	200	250	400	560	710	900
• At $I_{\text{H DC}}$ (50 Hz 400 V)	kW	160	200	315	450	560	705
• At $I_{\text{rated DC}}$ (60 Hz 460 V)	hp	305	385	615	860	1090	1390
• At $I_{\text{H DC}}$ (60 Hz 460 V)	hp	245	305	485	690	860	1090
DC link current							
• Rated current $I_{\text{rated DC}}$	A	420	530	820	1200	1500	1880
• Base-load current $I_{\text{H DC}}^{1)}$	A	328	413	640	936	1170	1467
• Maximum current $I_{\text{max DC}}$	A	630	795	1230	1800	2250	2820
Input current							
• Rated current $I_{\text{rated I}}$	A	365	460	710	1010	1265	1630
• Maximum current $I_{\text{max I}}$	A	547	690	1065	1515	1897	2380
Current demand							
• 24 V DC auxiliary power supply	A	1.1	1.1	1.1	1.1	1.1	1.1
• 400 V AC ²⁾	A	Internal	Internal	Internal	Internal	Internal	Internal
DC link capacitance							
• Basic Line Module	μF	7200	9600	14600	23200	29000	34800
• Drive line-up, max.	μF	57600	76800	116800	185600	232000	139200
Power loss, max. ³⁾							
• At 50 Hz 400 V	kW	1.9	2.1	3.2	4.6	5.5	6.9
• At 60 Hz 460 V	kW	1.9	2.1	3.2	4.6	5.5	6.9
Cooling air requirement		m ³ /s	0.17	0.17	0.17	0.36	0.36
Sound pressure level L_{pA} (1 m) at 50/60 Hz		dB	66/68	66/68	66/68	71/73	71/73
PE/GND connection		PE bar	PE bar	PE bar	PE bar	PE bar	PE bar
• Busbar cross-section	mm ²	600	600	600	600	600	600
• Conductor cross section, max. (IEC)	mm ²	240	240	240	240	240	240
Cable length, max. ⁴⁾							
• Shielded	m	2600	2600	2600	4000	4000	4800
• Unshielded	m	3900	3900	3900	6000	6000	7200
Degree of protection		IP20	IP20	IP20	IP20	IP20	IP20
Dimensions							
• Width	mm	400	400	400	400/600/600	400/600/600	400/600/600
• Height ⁵⁾	mm	2200	2200	2200	2200	2200	2200
• Depth	mm	600	600	600	600	600	600
Weight, approx.		kg	166	166	166	320/440/480	320/440/480
Frame size		FB	FB	FB	GB	GB	GD
Short-circuit current rating according to IEC		kA	65	65	65	84	100
Minimum short-circuit current ⁶⁾		A	4400	5200	10000	2500	3200
• For connection in parallel	A	–	–	–	4000	5000	6400

¹⁾ The base-load current $I_{\text{H DC}}$ is the basis for a duty cycle of 150 % for 60 s or $I_{\text{max DC}}$ for 5 s with a duty cycle duration of 300 s.

²⁾ The current demand for the 400 V AC auxiliary power supply is drawn from the line input voltage.

³⁾ The specified power loss represents the maximum value at 100% utilization. The value is lower under normal operating conditions.

⁴⁾ Total of all motor cables and DC link. Longer cable lengths for specific configurations are available on request.

⁵⁾ The cabinet height increases by 250 mm with degree of protection IP21, and by 400 mm with degrees of protection IP23, IP43 or IP54.

⁶⁾ Current required to ensure reliable tripping of installed protective devices.

SINAMICS S120 Cabinet Modules

Air-cooled units

Basic Line Modules

Technical specifications (continued)

Line voltage 500 ... 690 V 3 AC		Basic Line Modules					
		6SL3730-1TG33-0AA3	6SL3730-1TG34-3AA3	6SL3730-1TG36-8AA3	6SL3730-1TG41-1AA3	6SL3730-1TG41-4AA3	6SL3730-1TG41-8AA3
For a parallel circuit configuration, mounted to the <u>right</u> of the Line Connection Module					6SL3730-1TG41-1BA3	6SL3730-1TG41-4BA3	6SL3730-1TG41-8BA3
For a parallel circuit configuration, mounted to the <u>left</u> of the Line Connection Module					6SL3730-1TG41-1BC3	6SL3730-1TG41-4BC3	6SL3730-1TG41-8BC3
Rated power							
• At $I_{\text{rated DC}}$ (50 Hz 690 V)	kW	250	355	560	900	1100	1500
• At $I_{\text{H DC}}$ (50 Hz 690 V)	kW	195	280	440	710	910	1220
• At $I_{\text{rated DC}}$ (50 Hz 500 V)	kW	175	250	390	635	810	1085
• At $I_{\text{H DC}}$ (50 Hz 500 V)	kW	165	235	365	595	755	1015
• At $I_{\text{rated DC}}$ (60 Hz 575 V)	hp	250	350	600	900	1250	1500
• At $I_{\text{H DC}}$ (60 Hz 575 V)	hp	200	300	450	800	1000	1250
DC link current							
• Rated current $I_{\text{rated DC}}$	A	300	430	680	1100	1400	1880
• Base-load current $I_{\text{H DC}}^{1)}$	A	234	335	530	858	1092	1467
• Maximum current $I_{\text{max DC}}$	A	450	645	1020	1650	2100	2820
Input current							
• Rated current $I_{\text{rated I}}$	A	260	375	575	925	1180	1580
• Maximum current $I_{\text{max I}}$	A	390	563	863	1388	1770	2370
Current demand							
• 24 V DC auxiliary power supply	A	1.1	1.1	1.1	1.1	1.1	1.1
• 500 V/690 V AC ²⁾	A	Internal	Internal	Internal	Internal	Internal	Internal
DC link capacitance							
• Basic Line Module	μF	3200	4800	7300	11600	15470	19500
• Drive line-up, max.	μF	25600	38400	58400	92800	123760	78000
Power loss, max. ³⁾							
• At 50 Hz 690 V	kW	1.5	2.1	3	5.4	5.8	7.3
• At 60 Hz 575 V	kW	1.5	2.1	3	5.4	5.8	7.3
Cooling air requirement		m ³ /s	0.17	0.17	0.17	0.36	0.36
Sound pressure level L_{pA} (1 m) at 50/60 Hz		dB	66/68	66/68	66/68	71/73	71/73
PE/GND connection		PE bar	PE bar	PE bar	PE bar	PE bar	PE bar
• Busbar cross-section	mm ²	600	600	600	600	600	600
• Conductor cross section, max. (IEC)	mm ²	240	240	240	240	240	240
Cable length, max. ⁴⁾							
• Shielded	m	1500	1500	1500	2250	2250	2750
• Unshielded	m	2250	2250	2250	3375	3375	4125
Degree of protection		IP20	IP20	IP20	IP20	IP20	IP20
Dimensions							
• Width	mm	400	400	400	400/600/600	400/600/600	400/600/600
• Height ⁵⁾	mm	2200	2200	2200	2200	2200	2200
• Depth	mm	600	600	600	600	600	600
Weight, approx.		kg	166	166	166	320/440/480	320/440/480
Frame size			FB	FB	FB	GB	GD
Short-circuit current rating according to IEC		kA	65	65	84	100	100
Minimum short-circuit current ⁶⁾		A	3000	4400	8000	2000	2500
• For connection in parallel	A	–	–	–	4000	5000	6400

¹⁾ The base-load current $I_{\text{H DC}}$ is the basis for a duty cycle of 150 % for 60 s or $I_{\text{max DC}}$ for 5 s with a duty cycle duration of 300 s.

²⁾ The current demand for the 500 V/690 V AC auxiliary power supply is drawn from the line input voltage.

³⁾ The specified power loss represents the maximum value at 100% utilization. The value is lower under normal operating conditions.

⁴⁾ Total of all motor cables and DC link. Longer cable lengths for specific configurations are available on request.

⁵⁾ The cabinet height increases by 250 mm with degree of protection IP21, and by 400 mm with degrees of protection IP23, IP43 or IP54.

⁶⁾ Current required to ensure reliable tripping of installed protective devices.

Overview



Smart Line Modules are non-regulated rectifier/regenerative units. The infeed occurs over a diode jumper, while stable, line-commutated regenerative feedback takes place via IGBTs with 100 % continuous energy regeneration. An autotransformer is not required for regenerative feedback.

The regenerative capability can be deactivated.

Smart Line Modules are suitable for connection to grounded TN/TT and non-grounded IT systems. The following voltages and power ratings are available:

Line voltage	Rated power
380 ... 480 V 3 AC	250 ... 800 kW
500 ... 690 V 3 AC	450 ... 1400 kW

The power ratings can be increased by connecting up to four identical Smart Line Modules in parallel.

For additional information, please refer to the [SINAMICS Low Voltage Engineering Manual](#).

Design

IGBTs (fundamental frequency-switched) serve as Smart Line Module power semiconductors. Because this reduces switching losses, a high percentage of the power unit current can be utilized.

The current flows in the direction of the infeed via the freewheeling diodes of the IGBTs. This means that the Smart Line Module behaves in a similar way to the Basic Line Module. If the DC link voltage increases due to regenerative operation of the drives, the IGBTs conduct the current, thus feeding the energy back into the supply system.

In contrast to Active Line Modules, Smart Line Modules do not require a line-side filter; all they require is a line reactor (4 % u_k). The unit has a built-in pre-charging circuit for the DC link capacitors. For this reason, a main contactor or a motor-driven circuit breaker is absolutely essential. By specifying the option with order code **L44** for the Line Connection Modules, these components are appropriately accommodated in the Line Connection Module.

Parallel connection of Smart Line Modules to increase power rating

Up to four Smart Line Modules with the same power rating can be connected in parallel in order to increase power. Current derating of 7.5% with respect to the rated current of each Smart Line Module must be taken into account when the system is dimensioned.

A connection of the Smart Line Modules connected in parallel using DRIVE-CLiQ must be taken into consideration during the engineering phase.

For additional information, please refer to the [SINAMICS Low Voltage Engineering Manual](#).

A 4% reactor is always required upstream of each Smart Line Module for the purpose of current symmetrization. This is integrated as standard. Just as with the Basic Line Modules, "mirror-image" power connections are available for Smart Line Modules, which enable parallel circuits to be realized in a compact design. Units that are arranged to the left of the Line Connection Module have the letter "C" at the penultimate position of the article number.

Example: 6SL3730-6TE41-1BC3 (see also the corresponding diagram for the Basic Line Modules).

Selection and ordering data

Rated power at 400 V	Rated infeed/regenerative feedback curr.	Note for a parallel connection	Smart Line Module
kW	A	Mounting onto a Line Connection Module	Article No.
Line voltage 380 ... 480 V 3 AC (DC link voltage 510 ... 650 V DC)			
250	463	–	6SL3730-6TE35-5AA3
355	614	–	6SL3730-6TE37-3AA3
500	883	–	6SL3730-6TE41-1AA3
		Right	6SL3730-6TE41-1BA3
		Left	6SL3730-6TE41-1BC3
630	1093	–	6SL3730-6TE41-3AA3
		Right	6SL3730-6TE41-3BA3
		Left	6SL3730-6TE41-3BC3
800	1430	–	6SL3730-6TE41-7AA3
		Right	6SL3730-6TE41-7BA3
		Left	6SL3730-6TE41-7BC3

Rated power at 690 V	Rated infeed/regenerative feedback curr.	Note for a parallel connection	Smart Line Module
kW	A	Mounting onto a Line Connection Module	Article No.
Line voltage 500 ... 690 V 3 AC (DC link voltage 675 ... 930 V DC)			
450	463	–	6SL3730-6TG35-5AA3
		–	6SL3730-6TG38-8AA3
710	757	Right	6SL3730-6TG38-8BA3
		Left	6SL3730-6TG38-8BC3
1000	1009	–	6SL3730-6TG41-2AA3
		Right	6SL3730-6TG41-2BA3
		Left	6SL3730-6TG41-2BC3
		–	6SL3730-6TG41-7AA3
1400	1430	Right	6SL3730-6TG41-7BA3
		Left	6SL3730-6TG41-7BC3

SINAMICS S120 Cabinet Modules

Air-cooled units

Smart Line Modules

Integration

4

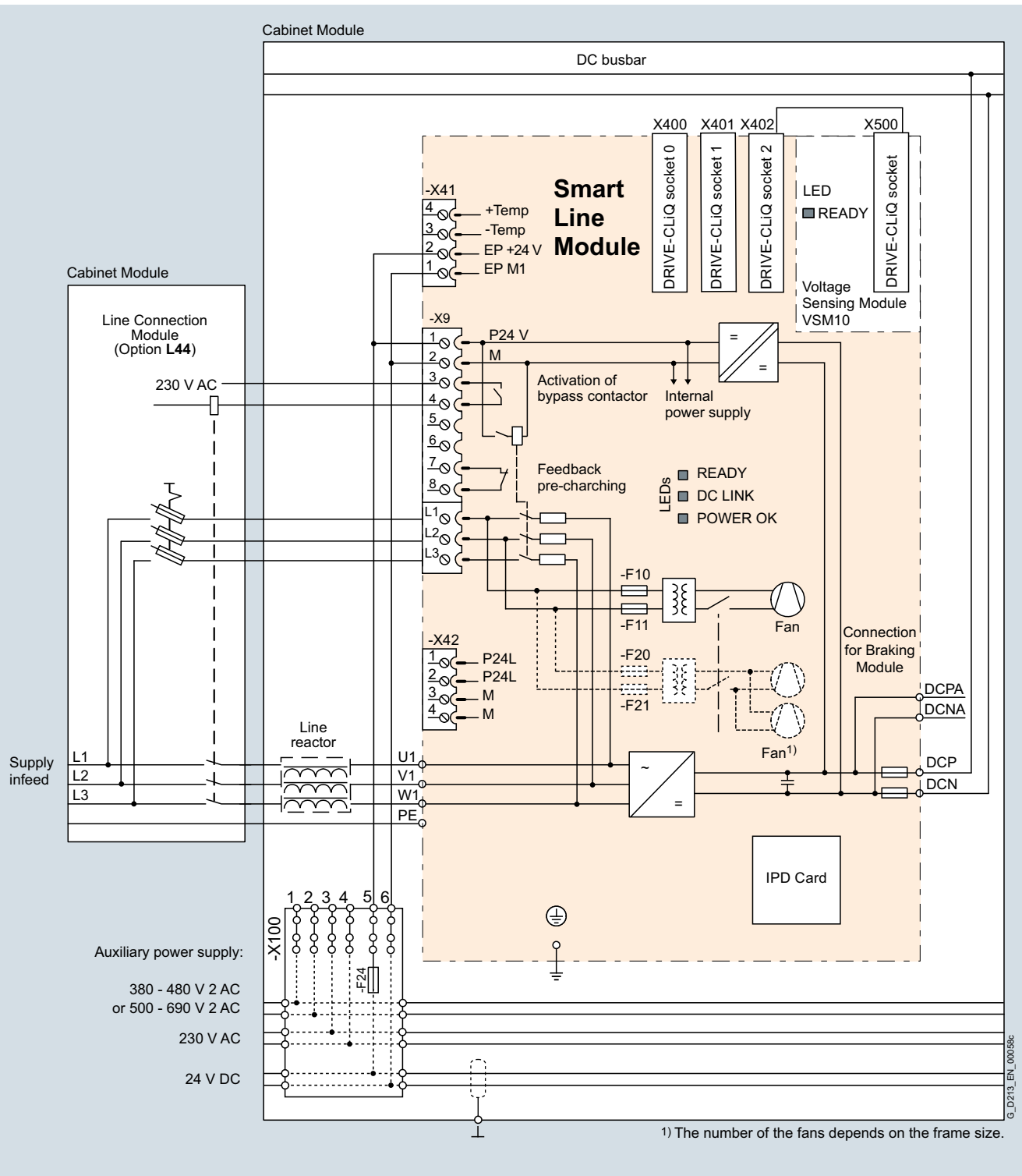

Connection example of a Smart Line Module

G_ D213_EN_00058c

Technical specifications

Line voltage 380 ... 480 V 3 AC		Smart Line Modules				
		6SL3730-6TE35-5AA3	6SL3730-6TE37-3AA3	6SL3730-6TE41-1AA3	6SL3730-6TE41-3AA3	6SL3730-6TE41-7AA3
For a parallel circuit configuration, mounted to the <u>right</u> of the Line Connection Module				6SL3730-6TE41-1BA3	6SL3730-6TE41-3BA3	6SL3730-6TE41-7BA3
For a parallel circuit configuration, mounted to the <u>left</u> of the Line Connection Module				6SL3730-6TE41-1BC3	6SL3730-6TE41-3BC3	6SL3730-6TE41-7BC3
Rated power						
• At $I_{\text{rated DC}}$ (50 Hz 400 V)	kW	250	355	500	630	800
• At $I_{\text{H DC}}$ (50 Hz 400 V)	kW	235	315	450	555	730
• At $I_{\text{rated DC}}$ (60 Hz 460 V)	hp	395	545	770	970	1230
• At $I_{\text{H DC}}$ (60 Hz 460 V)	hp	360	485	695	855	1125
DC link current						
• Rated current $I_{\text{rated DC}}$	A	550	730	1050	1300	1700
• Base-load current $I_{\text{H DC}}^{1)}$	A	490	650	934	1157	1513
• Maximum current $I_{\text{max DC}}$	A	825	1095	1575	1950	2550
Infeed/regenerative feedback current						
• Rated current $I_{\text{rated I}}$	A	463	614	883	1093	1430
• Maximum current $I_{\text{max I}}$	A	694	921	1324	1639	2145
Current demand						
• 24 V DC auxiliary power supply	A	1.35	1.35	1.4	1.5	1.7
• 400 V AC ²⁾	A	1.8	1.8	3.6	5.4	5.4
DC link capacitance						
• Smart Line Module	μF	8400	12000	16800	18900	28800
• Drive line-up, max.	μF	42000	60000	67200	75600	115200
Power loss, max. ³⁾						
• At 50 Hz 400 V	kW	3.7	4.7	7.1	11.0	11.5
• At 60 Hz 460 V	kW	3.7	4.7	7.1	11.0	11.5
Cooling air requirement		m ³ /s	0.36	0.36	0.78	1.08
Sound pressure level L_{pA} (1 m) at 50/60 Hz		dB	69/73	69/73	70/73	70/73
PE/GND connection		PE bar	PE bar	PE bar	PE bar	PE bar
• Busbar cross-section	mm ²	600	600	600	600	600
• Conductor cross section, max. (IEC)	mm ²	240	240	240	240	240
Cable length, max. ⁴⁾						
• Shielded	m	4000	4000	4800	4800	4800
• Unshielded	m	6000	6000	7200	7200	7200
Degree of protection		IP20	IP20	IP20	IP20	IP20
Dimensions						
• Width	mm	400	400	600	800	800
• Height ⁵⁾	mm	2200	2200	2200	2200	2200
• Depth	mm	600	600	600	600	600
Weight, approx.		kg	270	270	490	775
Frame size		GX	GX	HX	JX	JX
Short-circuit current rating according to IEC		kA	65	65	84	100
Minimum short-circuit current ⁶⁾		A	6200	9200	2000	2500

¹⁾ The base-load current $I_{\text{H DC}}$ is the basis for a duty cycle of 150 % for 60 s or $I_{\text{max DC}}$ for 5 s with a duty cycle duration of 300 s.

²⁾ The current demand for the 400 V AC auxiliary power supply is drawn from the line input voltage.

³⁾ The specified power loss represents the maximum value at 100% utilization. The value is lower under normal operating conditions.

⁴⁾ Total of all motor cables and DC link. Longer cable lengths for specific configurations are available on request.

⁵⁾ The cabinet height increases by 250 mm with degree of protection IP21, and by 400 mm with degrees of protection IP23, IP43 or IP54.

⁶⁾ Current required to ensure reliable tripping of installed protective devices.

SINAMICS S120 Cabinet Modules

Air-cooled units

Smart Line Modules

Technical specifications (continued)

Line voltage 500 ... 690 V 3 AC		Smart Line Modules			
		6SL3730-6TG35-5AA3	6SL3730-6TG38-8AA3	6SL3730-6TG41-2AA3	6SL3730-6TG41-7AA3
For a parallel circuit configuration, mounted to the <u>right</u> of the Line Connection Module			6SL3730-6TG38-8BA3	6SL3730-6TG41-2BA3	6SL3730-6TG41-7BA3
For a parallel circuit configuration, mounted to the <u>left</u> of the Line Connection Module			6SL3730-6TG38-8BC3	6SL3730-6TG41-2BC3	6SL3730-6TG41-7BC3
Rated power					
• At $I_{\text{rated DC}}$ (50 Hz 690 V)	kW	450	710	1000	1400
• At $I_{\text{H DC}}$ (50 Hz 690 V)	kW	405	665	885	1255
• At $I_{\text{rated DC}}$ (50 Hz 500 V)	kW	320	525	705	995
• At $I_{\text{H DC}}$ (50 Hz 500 V)	kW	295	480	640	910
• At $I_{\text{rated DC}}$ (60 Hz 575 V)	hp	500	790	1115	1465
• At $I_{\text{H DC}}$ (60 Hz 575 V)	hp	450	740	990	1400
DC link current					
• Rated current $I_{\text{rated DC}}$	A	550	900	1200	1700
• Base-load current $I_{\text{H DC}}^{(1)}$	A	490	800	1068	1513
• Maximum current $I_{\text{max DC}}$	A	825	1350	1800	2550
Infeed/regenerative feedback current					
• Rated current $I_{\text{rated I}}$	A	463	757	1009	1430
• Maximum current $I_{\text{max I}}$	A	694	1135	1513	2145
Current demand					
• 24 V DC auxiliary power supply	A	1.35	1.4	1.5	1.7
• 500 V AC ²⁾	A	1.3	2.9	4.3	4.3
• 690 V AC	A	1	2.1	3.1	3.1
DC link capacitance					
• Smart Line Module	μF	5600	7400	11100	14400
• Drive line-up, max.	μF	28000	29600	44400	57600
Power loss, max. ³⁾					
• At 50 Hz 690 V	kW	4.3	6.5	12.0	13.8
• At 60 Hz 575 V	kW	4.3	6.5	12.0	13.8
Cooling air requirement		m ³ /s	0.36	0.78	1.08
Sound pressure level L_{pA} (1 m) at 50/60 Hz		dB	69/73	70/73	70/73
PE/GND connection		PE bar	PE bar	PE bar	PE bar
• Busbar cross-section	mm ²	600	600	600	600
• Conductor cross section, max. (IEC)	mm ²	240	240	240	240
Cable length, max. ⁴⁾					
• Shielded	m	2250	2750	2750	2750
• Unshielded	m	3375	4125	4125	4125
Degree of protection		IP20	IP20	IP20	IP20
Dimensions					
• Width	mm	400	600	800	800
• Height ⁵⁾	mm	2200	2200	2200	2200
• Depth	mm	600	600	600	600
Weight, approx.		kg	270	550	795
Frame size		GX	HX	JX	JX
Short-circuit current rating according to IEC		kA	65	100	100
Minimum short-circuit current ⁶⁾		A	6200	10500	3200

¹⁾ The base-load current $I_{\text{H DC}}$ is the basis for a duty cycle of 150 % for 60 s or $I_{\text{max DC}}$ for 5 s with a duty cycle duration of 300 s.

²⁾ The current demand for the 500 V / 690 V AC auxiliary power supply is drawn from the line input voltage.

³⁾ The specified power loss represents the maximum value at 100% utilization. The value is lower under normal operating conditions.

⁴⁾ Total of all motor cables and DC link. Longer cable lengths for specific configurations are available on request.

⁵⁾ The cabinet height increases by 250 mm with degree of protection IP21, and by 400 mm with degrees of protection IP23, IP43 or IP54.

⁶⁾ Current required to ensure reliable tripping of installed protective devices.

SINAMICS S120 Cabinet Modules

Air-cooled units

Active Line Modules including Active Interface Modules

Overview



Active Line Modules are regulated rectifier/regenerative units. They can supply energy to the DC link and return regenerative energy to the supply system.

In contrast to Basic Line Modules and Smart Line Modules, Active Line Modules generate a stabilized DC voltage that is kept constant despite fluctuations in the line voltage (the line voltage must remain within the permissible tolerance range). Active Line Modules draw a virtually sinusoidal current from the supply system and therefore do not cause any harmful current harmonics.

Braking Modules and braking resistors are required only if the drives need to be decelerated in a controlled manner after a power failure (i.e. when energy cannot be recovered to the supply).

Active Line Modules are suitable for connection to grounded TN/TT and non-grounded IT systems. The following voltages and power ratings are available:

Line voltage	Rated power
380 ... 480 V 3 AC	132 ... 900 kW
500 ... 690 V 3 AC	560 ... 1400 kW

Design

Active Line Modules are always operated together with an Active Interface Module that contains the associated Clean Power Filter and pre-charging circuit. The integrated line filter ensures compliance with the EMC requirements for the "second environment".

The Active Line Module and Active Interface Module are supplied as a complete, fully wired unit, i.e. the customer does not need to supply any further cables or carry out any other wiring tasks.

Parallel connection of Active Line Modules to increase power rating

Active Line Modules are available for creating drive line-ups with more power. These modules can be operated in parallel on a common Line Connection Module and are arranged to the right and left of the Line Connection Module.

The power connections on the Active Line Module on the left of the Line Connection Module are a mirror image (article no. with "C" in the next to last position, example: 6SL3730-7T.41.-BC3), which results in a very compact design for the line infeed.

Please note that only Active Line Modules with exactly the same power rating may be connected in parallel. The potential for imbalances in current distribution means that a current derating of 5% applies; this must be taken into account when the modules are dimensioned.

A connection of the Active Line Modules connected in parallel using DRIVE-CLiQ must be taken into consideration during the engineering phase.

For additional information, please refer to the [SINAMICS Low Voltage Engineering Manual](#).

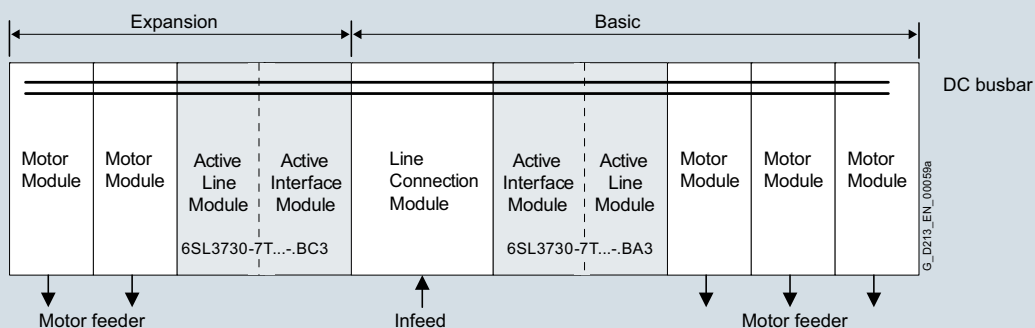

SINAMICS S120 Cabinet Modules

Air-cooled units

Active Line Modules including Active Interface Modules

Selection and ordering data

Rated power at 400 V kW	Rated infeed/ regenerative feedback current A	Note for a parallel connection <i>Mounting onto a Line Connection Module</i>	Active Line Module (incl. Active Interface Module) Article No.
Line voltage 380 ... 480 V 3 AC (DC link voltage 540 ... 720 V DC)			
132	210	–	6SL3730-7TE32-1BA3
160	260	–	6SL3730-7TE32-6BA3
235	380	–	6SL3730-7TE33-8BA3
300	490	–	6SL3730-7TE35-0BA3
380	605	–	6SL3730-7TE36-1BA3
500	840	–	6SL3730-7TE38-4BA3
630	985	–	6SL3730-7TE41-0BA3
		<i>Left</i>	6SL3730-7TE41-0BC3
900	1405	–	6SL3730-7TE41-4BA3
		<i>Left</i>	6SL3730-7TE41-4BC3

Rated power at 690 V kW	Rated infeed/ regenerative feedback current A	Note for a parallel connection <i>Mounting onto a Line Connection Module</i>	Active Line Module (incl. Active Interface Module) Article No.
Line voltage 500 ... 690 V 3 AC (DC link voltage 710 ... 1035 V DC)			
630	575	–	6SL3730-7TG35-8BA3
800	735	–	6SL3730-7TG37-4BA3
		<i>Left</i>	6SL3730-7TG37-4BC3
1100	1025	–	6SL3730-7TG41-0BA3
		<i>Left</i>	6SL3730-7TG41-0BC3
1400	1270	–	6SL3730-7TG41-3BA3
		<i>Left</i>	6SL3730-7TG41-3BC3

Integration

The Active Line Module is controlled by the CU320-2 Control Unit. Communication between the Control Unit and module is established via DRIVE-CLiQ connections. The Active Interface Module is included in the scope of delivery for the Active Line Module.

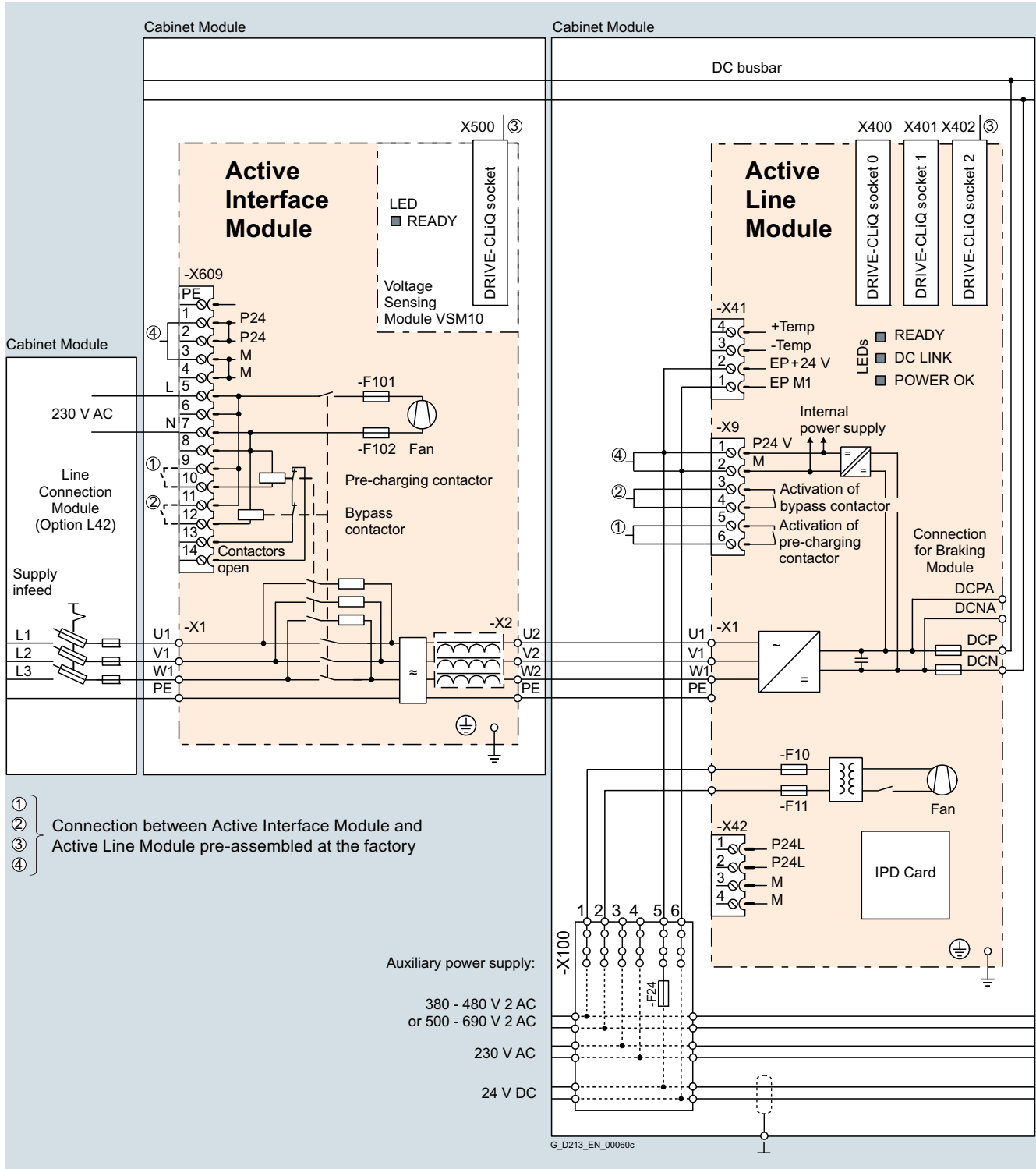

Example of connection of an Active Line Module (frame size FI/FX and GI/GX)

SINAMICS S120 Cabinet Modules

Air-cooled units

Active Line Modules including Active Interface Modules

Integration (continued)

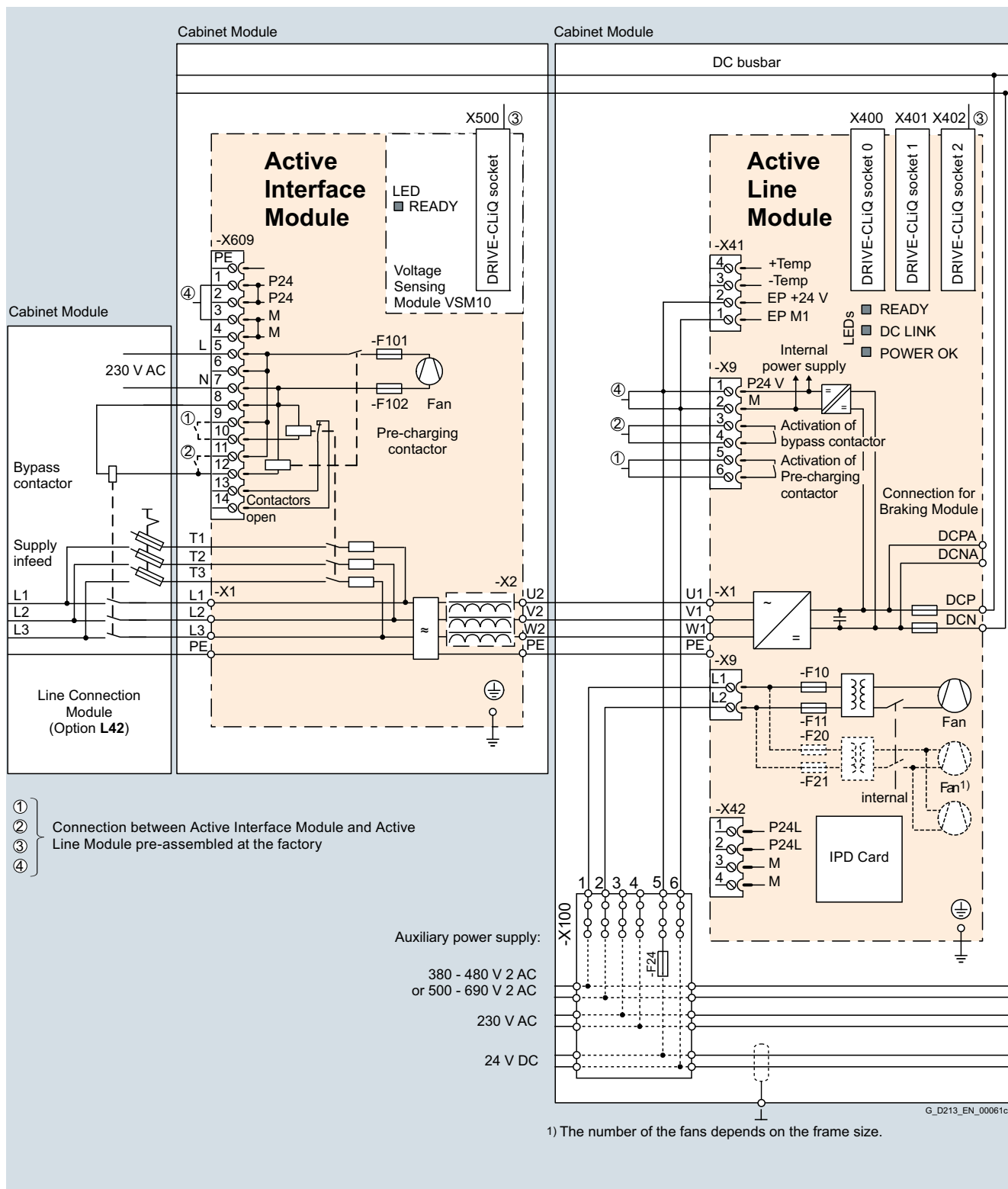

Example of connection of an Active Line Module (frame size HI/HX and JI/JX)

Technical specifications

Line voltage 380 ... 480 V 3 AC		Active Line Modules								
		6SL3730-7TE32-1BA3	6SL3730-7TE32-6BA3	6SL3730-7TE33-8BA3	6SL3730-7TE35-0BA3	6SL3730-7TE36-1BA3	6SL3730-7TE38-4BA3	6SL3730-7TE41-0BA3 6SL3730-7TE41-0BC3	6SL3730-7TE41-4BA3 6SL3730-7TE41-4BC3	
<i>For a parallel circuit configuration, mounted to the left of the Line Connection Module</i>										
Rated power										
• At $I_{\text{rated DC}}$ (50 Hz 400 V)	kW	132	160	235	300	380	500	630	900	
• At $I_{\text{H DC}}$ (50 Hz 400 V)	kW	115	145	210	270	335	465	545	780	
• At $I_{\text{rated DC}}$ (60 Hz 460 V)	hp	200	250	400	500	600	700	900	1250	
• At $I_{\text{H DC}}$ (60 Hz 460 V)	hp	150	200	300	400	500	700	800	1000	
DC link current										
• Rated current $I_{\text{rated DC}}$	A	235	291	425	549	678	940	1103	1574	
• Base-load current $I_{\text{H DC}}^{(1)}$	A	209	259	378	489	603	837	982	1404	
• Maximum current $I_{\text{max DC}}$	A	352	436	637	823	1017	1410	1654	2361	
Infeed/regenerative feedback current										
• Rated current $I_{\text{rated I}}$	A	210	260	380	490	605	840	985	1405	
• Maximum current $I_{\text{max I}}$	A	315	390	570	735	907	1260	1477	2107	
Current demand										
• 24 V DC auxiliary power supply	A	1.27	1.27	1.52	1.52	1.57	1.57	1.67	1.67	
• 230 V AC auxiliary power supply	A	0.6	0.6	1.2	1.2	4.6	4.6	4.9	4.9	
• 400 V AC ²⁾	A	0.63	1.13	1.8	1.8	3.6	3.6	5.4	5.4	
DC link capacitance										
• Active Line Module	μF	4200	5200	7800	9600	12600	16800	18900	28800	
• Drive line-up, max.	μF	41600	41600	76800	76800	134400	134400	230400	230400	
Power loss, max. ³⁾										
• At 50 Hz 400 V	kW	4.3	4.9	6.9	8.7	11.7	13.8	17.6	21.8	
• At 60 Hz 460 V	kW	4.4	5.1	7.2	9.0	12.1	14.3	18.3	22.7	
Cooling air requirement		m ³ /s	0.47	0.47	0.83	0.83	1.18	1.18	1.48	1.48
Sound pressure level L_{pA} ⁴⁾ (1 m) at 50/60 Hz		dB	71/73	71/73	72/74	72/74	77/79	77/79	78/80	78/80
PE/GND connection		PE bar	PE bar	PE bar	PE bar	PE bar	PE bar	PE bar	PE bar	
• Busbar cross-section	mm ²	600	600	600	600	600	600	600	600	
• Conductor cross section, max. (IEC)	mm ²	240	240	240	240	240	240	240	240	
Cable length, max. ⁵⁾										
• Shielded	m	2700	2700	2700	2700	3900	3900	3900	3900	
• Unshielded	m	4050	4050	4050	4050	5850	5850	5850	5850	
Degree of protection		IP20	IP20	IP20	IP20	IP20	IP20	IP20	IP20	
Dimensions										
• Width	mm	800	800	800	800	1000	1000	1400	1400	
• Height ⁶⁾	mm	2200	2200	2200	2200	2200	2200	2200	2200	
• Depth	mm	600	600	600	600	600	600	600	600	
Weight, approx.		kg	380	380	530	530	930	930	1360	1360
Frame size		FX + FI	FX + FI	GX + GI	GX + GI	HX + HI	HX + HI	JX + JI	JX + JI	
Short-circuit current rating according to IEC		kA	65	65	65	65	65	84	84	100
Minimum short-circuit current ⁷⁾		A	6200	10500	10500	10500	12000	2000	4000	6400

¹⁾ The base-load current $I_{\text{H DC}}$ is the basis for a duty cycle of 150 % for 60 s or $I_{\text{max DC}}$ for 5 s with a duty cycle duration of 300 s.

²⁾ The current demand for the 400 V AC auxiliary power supply is drawn from the line input voltage.

³⁾ The specified power loss represents the maximum value at 100% utilization. The value is lower under normal operating conditions.

⁴⁾ Total sound pressure level of Active Interface Module and Active Line Module.

⁵⁾ Total of all motor cables and DC link. Longer cable lengths for specific configurations are available on request.

⁶⁾ The cabinet height increases by 250 mm with degree of protection IP21, and by 400 mm with degrees of protection IP23, IP43 or IP54.

⁷⁾ Current required to ensure reliable tripping of installed protective devices.

SINAMICS S120 Cabinet Modules

Air-cooled units

Active Line Modules including Active Interface Modules

Technical specifications (continued)

Line voltage 500 ... 690 V 3 AC		Active Line Modules			
For a parallel circuit configuration, mounted to the left of the Line Connection Module		6SL3730-7TG35-8BA3	6SL3730-7TG37-4BA3 6SL3730-7TG37-4BC3	6SL3730-7TG41-0BA3 6SL3730-7TG41-0BC3	6SL3730-7TG41-3BA3 6SL3730-7TG41-3BC3
Rated power					
• At $I_{\text{rated DC}}$ (50 Hz 690 V)	kW	630	800	1100	1400
• At $I_{\text{H DC}}$ (50 Hz 690 V)	kW	620	705	980	1215
• At $I_{\text{rated DC}}$ (50 Hz 500 V)	kW	447	560	780	965
• At $I_{\text{H DC}}$ (50 Hz 500 V)	kW	450	510	710	880
• At $I_{\text{rated DC}}$ (60 Hz 575 V)	hp	675	900	1250	1500
• At $I_{\text{H DC}}$ (60 Hz 575 V)	hp	506	600	1000	1250
DC link current					
• Rated current $I_{\text{rated DC}}$	A	644	823	1148	1422
• Base-load current $I_{\text{H DC}}^{1)}$	A	573	732	1022	1266
• Maximum current $I_{\text{max DC}}$	A	966	1234	1722	2133
Infeed/regenerative feedback current					
• Rated current $I_{\text{rated I}}$	A	575	735	1025	1270
• Maximum current $I_{\text{max I}}$	A	862	1102	1537	1905
Current demand ²⁾					
• 24 V DC auxiliary power supply	A	1.57	1.67	1.87	1.87
• 230 V AC auxiliary power supply	A	4.6	4.9	4.9	4.9
• 500 V AC	A	3.0	4.4	4.4	4.4
• 690 V AC	A	2.1	3.1	3.1	3.1
DC link capacitance					
• Active Line Module	μF	7400	11100	14400	19200
• Drive line-up, max.	μF	59200	153600	153600	153600
Power loss, max. ³⁾					
• At 50 Hz 500/690 V	kW	13.6	19.2	22.8	26.1
• At 60 Hz 575 V	kW	13.0	18.6	22.1	24.9
Cooling air requirement					
	m ³ /s	1.18	1.48	1.48	1.48
Sound pressure level L_{pA} ⁴⁾					
(1 m) at 50/60 Hz	dB	77/79	77/79	77/79	77/79
PE/GND connection					
• Busbar cross-section	mm ²	600	600	600	600
• Conductor cross section, max. (IEC)	mm ²	240	240	240	240
Cable length, max. ⁵⁾					
• Shielded	m	2250	2250	2250	2250
• Unshielded	m	3375	3375	3375	3375
Degree of protection					
		IP20	IP20	IP20	IP20
Dimensions					
• Width	mm	1000	1400	1400	1400
• Height ⁶⁾	mm	2200	2200	2200	2200
• Depth	mm	600	600	600	600
Weight, approx.					
	kg	930	1360	1360	1360
Frame size					
		HX + HI	JX + JI	JX + JI	JX + JI
Short-circuit current rating according to IEC					
	kA	65	84	100	100
Minimum short-circuit current ⁷⁾					
• For connection in parallel	A	9000	10500	2500	3200
	A	–	4000	4000	5000

¹⁾ The base-load current $I_{\text{H DC}}$ is the basis for a duty cycle of 150 % for 60 s or $I_{\text{max DC}}$ for 5 s with a duty cycle duration of 300 s.

²⁾ The current demand for the 500 V/690 V AC auxiliary power supply is drawn from the line input voltage.

³⁾ The specified power loss represents the maximum value at 100% utilization. The value is lower under normal operating conditions.

⁴⁾ Total sound pressure level of Active Interface Module and Active Line Module.

⁵⁾ Total of all motor cables and DC link. Longer cable lengths for specific configurations are available on request.

⁶⁾ The cabinet height increases by 250 mm with degree of protection IP21, and by 400 mm with degrees of protection IP23, IP43 or IP54.

⁷⁾ Current required to ensure reliable tripping of installed protective devices.

SINAMICS S120 Cabinet Modules

Air-cooled units

Motor Modules Booksize format

Overview



Motor Modules in Booksize format are also available as Booksize Cabinet Kits in voltage class 380 V to 480 V (DC link voltage 510 V to 720 V).

Motor Modules are also available as Single Motor Modules for power ratings of 4.8 kW to 71 kW for connection of a motor.

Design

Motor Modules Booksize format are installed in the factory as Booksize Cabinet Kits in Booksize Base Cabinets. This complete unit contains all of the components necessary for operation.

Several Booksize Cabinet Kits can be installed in one Booksize Base Cabinet, depending on the installation width requirements, which in turn depend on the power rating. The number of Booksize Cabinet Kits that can be installed in a Booksize Base Cabinet is determined solely on the basis of the available cabinet width. By changing the way in which the cabinet width is used (i.e. the equipment that is installed), it can be adapted to suit system requirements.

Each Motor Module is connected separately to the DC busbar of the SINAMICS S120 Cabinet Module via a separate fuse switch disconnecter with integrated fuses. The DC connecting busbar integrated in the units is not used.

The basic version of the Booksize Cabinet Kit comprises the following components:

- Motor Module in booksize format
- Fuse switch disconnecter for each Motor Module installed
- Customer interface -X55.1 located in the connection area of the Booksize Base Cabinet
- Shield connection plate
- Complete electrical connection to the Booksize Base Cabinet interfaces

The Booksize Base Cabinets can be operated up to and including IP54 degree of protection without additional temperature derating. However, some values need to be taken into account that differ from those of the chassis format. [For derating data, see System overview > Characteristic curves.](#)

Selection and ordering data

Type rating at 400 V kW	Rated output current I_{rated} A	Width mm	Single Motor Module Booksize Cabinet Kit Article No.
Line voltage 380 ... 480 V 3 AC (DC link voltage 510 ... 720 V DC)			
4.8	9	100	6SL3720-1TE21-0AB3
9.7	18	100	6SL3720-1TE21-8AB3
16	30	100	6SL3720-1TE23-0AB3
24	45	200	6SL3720-1TE24-5AB3
32	60	200	6SL3720-1TE26-0AB3
46	85	200	6SL3720-1TE28-5AB3
71	132	300	6SL3720-1TE31-3AB3

Booksize Cabinet Kits must always be ordered in combination with at least one Booksize Base Cabinet (cannot be supplied as a single unit).

The required number of Booksize Cabinet Kits installed in a Booksize Base Cabinet must be stated in plain text in the order. The number of possible kits is limited only by the usable installation width of the Booksize Base Cabinet.

Booksize Base Cabinets ready to be installed in the Booksize Cabinet Kits:

Usable installation width mm	Weight, approx. kg	Dimensions with degree of protection IP20 ¹⁾ (W × D × H) mm	Booksize Base Cabinet Article No.
600	170	800 × 600 × 2200	6SL3720-1TX38-0AA3
1000	240	1200 × 600 × 2200	6SL3720-1TX41-2AA3

¹⁾ The cabinet height increases by 250 mm with degree of protection IP21, 400 mm with degrees of protection IP23, IP43 and IP54.

SINAMICS S120 Cabinet Modules

Air-cooled units

Motor Modules Booksize format

Integration

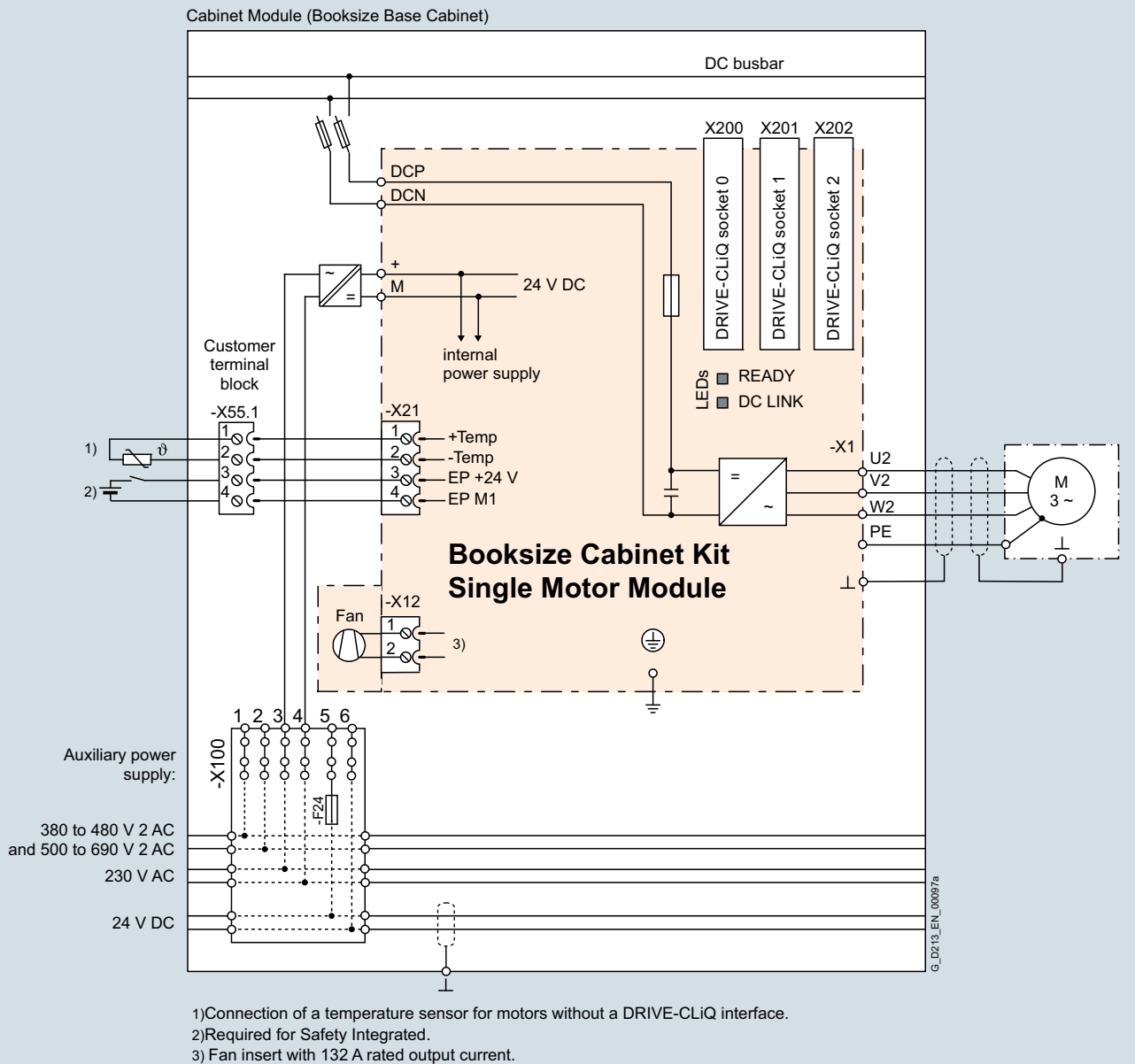

Connection example of a Booksize Cabinet Kit (Single Motor Module in booksize format) in Booksize Base Cabinet

Technical specifications

Line voltage 380 ... 480 V 3 AC DC link voltage 510 ... 720 V DC		Single Motor Modules Booksize Cabinet Kit			
		6SL3720-1TE21-0AB3	6SL3720-1TE21-8AB3	6SL3720-1TE23-0AB3	6SL3720-1TE24-5AB3
Type rating					
• At I_L (50 Hz 400 V) ¹⁾	kW	4.8	9.7	16	24
• At I_H (50 Hz 400 V) ¹⁾	kW	4.1	8.2	13.7	21
• At I_L (60 Hz 460 V) ²⁾	hp	5	10	20	30
• At I_H (60 Hz 460 V) ²⁾	hp	5	10	15	25
Output current					
• Rated current $I_{rated O}$	A	9	18	30	45
• Base-load current I_H ³⁾	A	7.7	15.3	25.5	38
• Maximum current $I_{max O}$	A	18	36	56	85
DC link current I_d ⁴⁾	A	11	22	36	54
Current demand					
• 24 V DC, max.	A	0.85	0.85	0.9	1.2
DC link capacitance	μF	110	220	710	1175
Pulse frequency ⁵⁾					
• Rated frequency	kHz	4	4	4	4
• Pulse frequency, max. - With current derating	kHz	16	16	16	16
Power loss, max. ⁶⁾					
• At 50 Hz 400 V	kW	0.08	0.165	0.29	0.43
• At 60 Hz 460 V	kW	0.08	0.165	0.29	0.43
Cooling air requirement	m ³ /s	0.008	0.008	0.016	0.031
Sound pressure level L_{pA} (1 m) at 50/60 Hz	dB	<60	<60	<60	<65
Motor connection U2, V2, W2		Terminal	Terminal	Terminal	Terminal
• Conductor cross section, max. (IEC)	mm ²	6	6	6	16
Cable length, max. ⁷⁾					
• Shielded	m	50	70	100	100
• Unshielded	m	75	100	150	150
PE/GND connection		PE bar	PE bar	PE bar	PE bar
• Busbar cross-section	mm ²	600	600	600	600
• Conductor cross section, max. (IEC)	mm ²	240	240	240	240
Degree of protection		IP20	IP20	IP20	IP20
Weight, approx.	kg	20	20	21.9	27
Width	mm	100	100	100	200
Short-circuit current rating according to IEC	kA	65	65	65	65

¹⁾ Rated output of a typical 6-pole standard induction motor based on I_L or I_H for 400 V 3 AC 50 Hz.

²⁾ Rated output of a typical 6-pole standard induction motor based on I_L or I_H for 460 V 3 AC 60 Hz.

³⁾ The base-load current I_L is based on a load cycle of 110 % for 60 s or 150 % for 10 s with a load cycle duration of 300 s.

⁴⁾ For a DC link voltage of 600 V DC.

⁵⁾ Information regarding the correlation between the pulse frequency and max. output current/output frequency is provided in the SINAMICS Low Voltage Engineering Manual.

⁶⁾ The specified power loss represents the maximum value at 100% utilization. The value is lower under normal operating conditions.

⁷⁾ Total of all motor cables. Longer cable lengths for specific configurations are available on request.

SINAMICS S120 Cabinet Modules

Air-cooled units

Motor Modules Booksize format

Technical specifications (continued)

Line voltage 380 ... 480 V 3 AC DC link voltage 510 ... 720 V DC		Single Motor Modules Booksize Cabinet Kit		
		6SL3720-1TE26-0AB3	6SL3720-1TE28-5AB3	6SL3720-1TE31-3AB3
Type rating				
• At I_L (50 Hz 400 V) ¹⁾	kW	32	46	71
• At I_H (50 Hz 400 V) ¹⁾	kW	28	37	57
• At I_L (60 Hz 460 V) ²⁾	hp	40	60	100
• At I_H (60 Hz 460 V) ²⁾	hp	40	50	75
Output current				
• Rated current $I_{rated O}$	A	60	85	132
• Base-load current I_H ³⁾	A	52	68	105
• Maximum current $I_{max O}$	A	113	141	210
DC link current I_d ⁴⁾	A	72	102	158
Current demand				
• 24 V DC, max.	A	1.2	1.5	1.5
DC link capacitance	μF	1410	1880	2820
Pulse frequency ⁵⁾				
• Rated frequency	kHz	4	4	4
• Pulse frequency, max. - With current derating	kHz	16	16	16
Power loss, max. ⁶⁾				
• At 50 Hz 400 V	kW	0.59	0.75	1.25
• At 60 Hz 460 V	kW	0.59	0.75	1.25
Cooling air requirement	m ³ /s	0.031	0.044	0.144
Sound pressure level L_{pA} (1 m) at 50/60 Hz	dB	<65	<60	<73
Motor connection U2, V2, W2		Terminal	Terminal	Terminal
• Conductor cross section, max. (IEC)	mm ²	16	35	70
Cable length, max. ⁷⁾				
• Shielded	m	100	100	100
• Unshielded	m	150	150	150
PE/GND connection		PE bar	PE bar	PE bar
• Busbar cross-section	mm ²	600	600	600
• Conductor cross section, max. (IEC)	mm ²	240	240	240
Degree of protection		IP20	IP20	IP20
Weight, approx.	kg	27	33	41
Width	mm	200	200	300
Short-circuit current rating according to IEC	kA	65	65	65

¹⁾ Rated output of a typical 6-pole standard induction motor based on I_L or I_H for 400 V 3 AC 50 Hz.

²⁾ Rated output of a typical 6-pole standard induction motor based on I_L or I_H for 460 V 3 AC 60 Hz.

³⁾ The base-load current I_L is based on a load cycle of 110 % for 60 s or 150 % for 10 s with a load cycle duration of 300 s.

⁴⁾ For a DC link voltage of 600 V DC.

⁵⁾ Information regarding the correlation between the pulse frequency and max. output current/output frequency is provided in the SINAMICS Low Voltage Engineering Manual.

⁶⁾ The specified power loss represents the maximum value at 100% utilization. The value is lower under normal operating conditions.

⁷⁾ Total of all motor cables. Longer cable lengths for specific configurations are available on request.

SINAMICS S120 Cabinet Modules

Air-cooled units

Motor Modules Chassis format

Overview



Motor Modules in chassis format are available in the power range from 75 kW to 1200 kW.

Line voltage	DC link voltage	Type rating
380 ... 480 V 3 AC	510 ... 720 V DC	110 ... 800 kW
500 ... 690 V 3 AC	675 ... 1035 V DC	75 ... 1200 kW

By connecting in parallel up to four Motor Modules operated on one Control Unit and which supply one motor, it is possible to increase the available shaft power to a maximum of approx. 4500 kW (taking into account the derating factors according to the SINAMICS Low Voltage Engineering Manual).

SINAMICS S120 Motor Modules in chassis format can also be used as a Braking Module if, instead of a motor, a 3-phase braking resistor is connected.

[For more detailed information on this topic, please refer to the SINAMICS Low Voltage Engineering Manual.](#)

Design

Motor Modules in chassis format contain the following components as standard:

- Retaining device for the DC busbar, including the connection to the DC connections of the Motor Module
- Nickel-plated connection busbars for motor cables for Motor Modules, frame sizes FX and GX; for Motor Modules, frame sizes HX and JX, the connection is made directly on the unit
- Cable retaining bar for the power cables
- DRIVE-CLiQ interface (3 DRIVE-CLiQ sockets), without Control Unit
- Customer interface -X55
- Auxiliary power supply system (6-pole) for the auxiliary power supply, including cable connections for looping through to the next Cabinet Module
- Nickel-plated PE busbar (60 x 10 mm), including jumper for looping through to the next Cabinet Module
- EMC-compliant design thanks to additional shielding measures and appropriately routed cables

Selection and ordering data

Type rating at 400 V or 690 V kW	Rated output current I_{rated} A	Motor Module in chassis format Article No.
Line voltage 380 ... 480 V 3 AC (DC link voltage 510 ... 720 V DC)		
110	210	6SL3720-1TE32-1AA3
132	260	6SL3720-1TE32-6AA3
160	310	6SL3720-1TE33-1AA3
200	380	6SL3720-1TE33-8AA3
250	490	6SL3720-1TE35-0AA3
315	605	6SL3720-1TE36-1AA3
400	745	6SL3720-1TE37-5AA3
450	840	6SL3720-1TE38-4AA3
560	985	6SL3720-1TE41-0AA3
710	1260	6SL3720-1TE41-2AA3
800	1405	6SL3720-1TE41-4AA3
Line voltage 500 ... 690 V 3 AC (DC link voltage 675 ... 1035 V DC)		
75	85	6SL3720-1TG28-5AA3
90	100	6SL3720-1TG31-0AA3
110	120	6SL3720-1TG31-2AA3
132	150	6SL3720-1TG31-5AA3
160	175	6SL3720-1TG31-8AA3
200	215	6SL3720-1TG32-2AA3
250	260	6SL3720-1TG32-6AA3
315	330	6SL3720-1TG33-3AA3
400	410	6SL3720-1TG34-1AA3
450	465	6SL3720-1TG34-7AA3
560	575	6SL3720-1TG35-8AA3
710	735	6SL3720-1TG37-4AA3
800	810	6SL3720-1TG38-1AA3
900	910	6SL3720-1TG38-8AA3
1000	1025	6SL3720-1TG41-0AA3
1200	1270	6SL3720-1TG41-3AA3

SINAMICS S120 Cabinet Modules

Air-cooled units

Motor Modules Chassis format

Integration

Motor Modules are controlled by the CU320-2 DP or CU320-2 PN Control Unit. Communication between the Control Unit and Modules is established via a DRIVE-CLiQ connection.

If the Control Unit is integrated in the same cabinet as an option with order code **K90** or **K95**, these communication cables will already be installed. If the Control Unit is to be mounted externally,

the DRIVE-CLiQ cable will not be included in the scope of delivery and must be configured on site.

For additional information, please refer to the [SINAMICS Low Voltage Engineering Manual](#).

For a description of the terminal block, see section [Customer terminal block -X55](#).

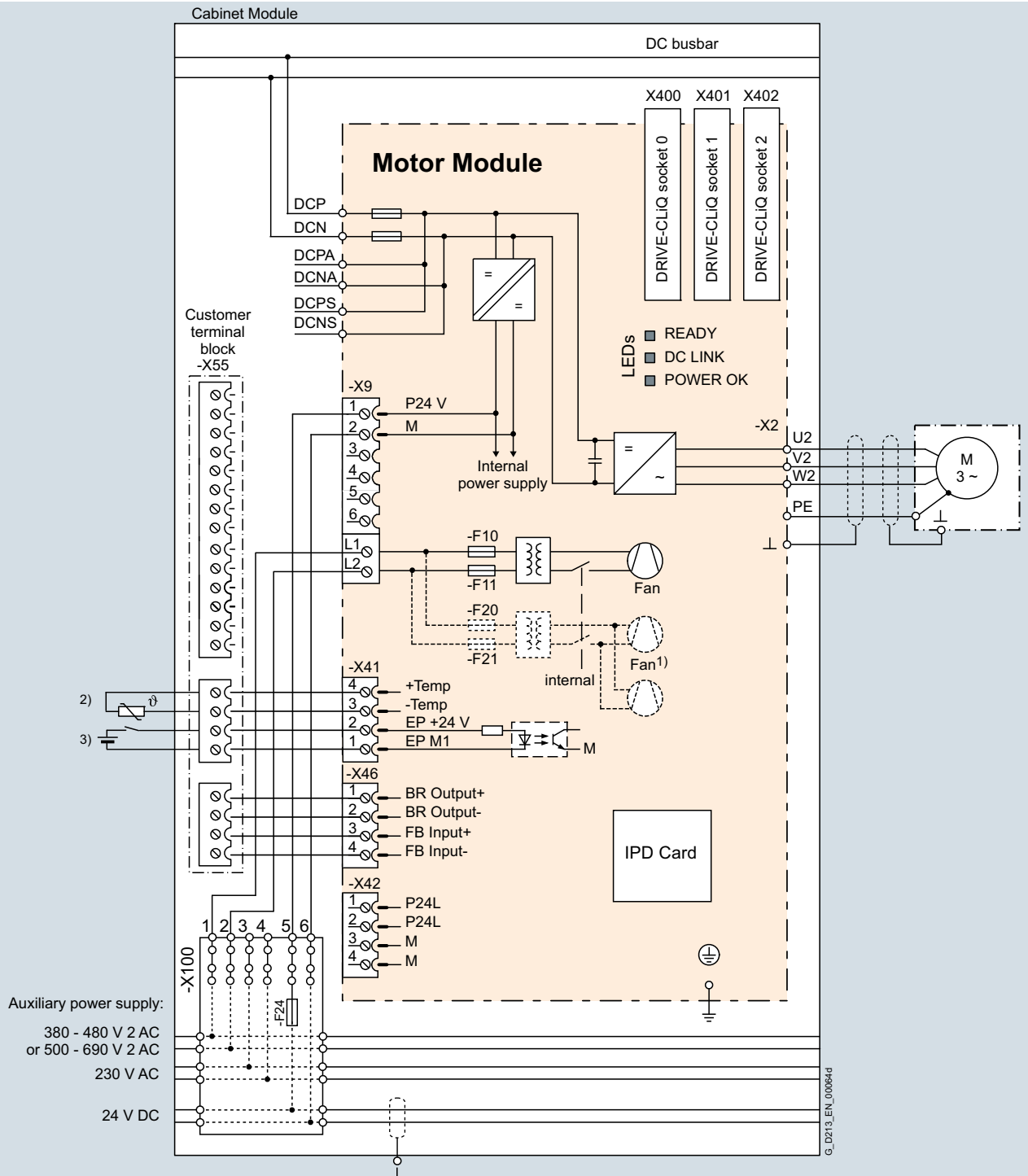

- 1) The number and the terminals of the fans depend on the frame size.
- 2) Connection of temperature sensor for motors without DRIVE-CLiQ interface.
- 3) Required for Safety Integrated.

Connection example: Motor Module in chassis format

Technical specifications

Line voltage 380 ... 480 V 3 AC DC link voltage 510 ... 720 V DC		Motor Modules in chassis format					
		6SL3720-1TE32-1AA3	6SL3720-1TE32-6AA3	6SL3720-1TE33-1AA3	6SL3720-1TE33-8AA3	6SL3720-1TE35-0AA3	6SL3720-1TE36-1AA3
Type rating							
• At I_L (50 Hz 400 V) ¹⁾	kW	110	132	160	200	250	315
• At I_H (50 Hz 400 V) ¹⁾	kW	90	110	132	160	200	250
• At I_L (60 Hz 460 V) ²⁾	hp	150	200	250	300	400	500
• At I_H (60 Hz 460 V) ²⁾	hp	150	200	200	250	350	350
Output current							
• Rated current $I_{rated O}$	A	210	260	310	380	490	605
• Base-load current I_L ³⁾	A	205	250	302	370	477	590
• Base-load current I_H ⁴⁾	A	178	233	277	340	438	460
• Maximum current $I_{max O}$	A	307	375	453	555	715	885
DC link current							
• Rated current $I_{rated DC}$ when supplied via							
- Basic/Smart Line Module	A	252	312	372	456	588	726
- Active Line Module	A	227	281	335	411	529	653
• Base-load current $I_{L DC}$ ³⁾ when supplied via							
- Basic/Smart Line Module	A	245	304	362	444	573	707
- Active Line Module	A	221	273	326	400	515	636
• Base-load current $I_{H DC}$ ⁴⁾ when supplied via							
- Basic/Smart Line Module	A	224	277	331	405	523	646
- Active Line Module	A	202	250	298	365	470	581
Current demand							
• 24 V DC auxiliary power supply	A	0.8	0.8	0.9	0.9	0.9	1.0
• 400 V AC	A	0.63	1.13	1.8	1.8	1.8	3.6
DC link capacitance		μF	4200	5200	6300	7800	9600
Pulse frequency ⁵⁾							
• Rated frequency	kHz	2	2	2	2	2	1.25
• Pulse frequency, max.							
- Without current derating	kHz	2	2	2	2	2	1.25
- With current derating	kHz	8	8	8	8	8	7.5
Power loss, max. ⁶⁾							
• At 50 Hz 400 V	kW	1.86	2.5	2.96	3.67	4.28	5.84
• At 60 Hz 460 V	kW	1.94	2.6	3.1	3.8	4.5	6.3
Cooling air requirement		m ³ /s	0.17	0.23	0.36	0.36	0.78
Sound pressure level L_{pA} (1 m) at 50/60 Hz		dB	67	69	69	69	72
Motor connection U2, V2, W2			M12 screws	M12 screws	M12 screws	M12 screws	M12 screws
• Conductor cross section, max. (IEC)	mm ²		2 × 185	2 × 185	2 × 240	2 × 240	4 × 240
Cable length, max. ⁷⁾							
• Shielded	m	300	300	300	300	300	300
• Unshielded	m	450	450	450	450	450	450
PE/GND connection			PE bar	PE bar	PE bar	PE bar	PE bar
• Busbar cross-section	mm ²	600	600	600	600	600	600
• Conductor cross section, max. (IEC)	mm ²	240	240	240	240	240	240
Degree of protection			IP20	IP20	IP20	IP20	IP20
Dimensions							
• Width ⁸⁾	mm	400	400	400	400	400	600
• Height ⁹⁾	mm	2200	2200	2200	2200	2200	2200
• Depth	mm	600	600	600	600	600	600
Weight, approx.		kg	145	145	286	286	490
Frame size			FX	FX	GX	GX	HX
Short-circuit current rating acc. to IEC		kA	65	65	65	65	65

¹⁾ Rated output of a typical 6-pole standard induction motor based on I_L or I_H for 400 V 3 AC 50 Hz.

²⁾ Rated output of a typical 6-pole standard induction motor based on I_L or I_H for 460 V 3 AC 60 Hz.

³⁾ The base-load current I_L is based on a load cycle of 110 % for 60 s or 150 % for 10 s with a load cycle duration of 300 s.

⁴⁾ The base-load current I_H is based on a duty cycle of 150 % for 60 s or 160 % for 10 s with a duty cycle duration of 300 s.

⁵⁾ Information regarding the correlation between the pulse frequency and max. output current/output frequency is provided in the SINAMICS Low Voltage Engineering Manual.

⁶⁾ The specified power loss represents the maximum value at 100% utilization. The value is lower under normal operating conditions.

⁷⁾ Total of all motor cables. Longer cable lengths for specific configurations are available on request. For additional information, please refer to the SINAMICS Low Voltage Engineering Manual.

⁸⁾ With option **L10** (dv/dt filter plus VPL):
 - Frame sizes FX/GX/HX/JX: Additional cabinet 600 mm wide
 With option **L34** (circuit breaker on the output side):
 - Frame size FX/GX: Additional cabinet 400 mm wide
 - Frame size HX/JX: Additional cabinet 600 mm wide.

⁹⁾ The cabinet height increases by 250 mm with degree of protection IP21, and by 400 mm with degrees of protection IP23, IP43 and IP54.

SINAMICS S120 Cabinet Modules

Air-cooled units

Motor Modules Chassis format

Technical specifications (continued)

Line voltage 380 ... 480 V 3 AC		Motor Modules in chassis format				
DC link voltage 510 ... 720 V DC		6SL3720-1TE37-5AA3	6SL3720-1TE38-4AA3	6SL3720-1TE41-0AA3	6SL3720-1TE41-2AA3	6SL3720-1TE41-4AA3
Type rating						
• At I_L (50 Hz 400 V) ¹⁾	kW	400	450	560	710	800
• At I_H (50 Hz 400 V) ¹⁾	kW	315	400	450	560	710
• At I_L (60 Hz 460 V) ²⁾	hp	600	700	800	1000	1150
• At I_H (60 Hz 460 V) ²⁾	hp	450	600	700	900	1000
Output current						
• Rated current $I_{rated O}$	A	745	840	985	1260	1405
• Base-load current $I_L^{(3)}$	A	725	820	960	1230	1370
• Base-load current $I_H^{(4)}$	A	570	700	860	1127	1257
• Maximum current $I_{max O}$	A	1087	1230	1440	1845	2055
DC link current						
• Rated current $I_{rated DC}$ when supplied via	A					
- Basic/Smart Line Module	A	894	1008	1182	1512	1686
- Active Line Module	A	805	907	1064	1361	1517
• Base-load current $I_L DC^{(3)}$ when supplied via	A					
- Basic/Smart Line Module	A	871	982	1152	1474	1643
- Active Line Module	A	784	884	1037	1326	1479
• Base-load current $I_H DC^{(4)}$ when supplied via	A					
- Basic/Smart Line Module	A	795	897	1051	1345	1500
- Active Line Module	A	716	807	946	1211	1350
Current demand						
• 24 V DC auxiliary power supply	A	1.0	1.0	1.25	1.4	1.4
• 400 V AC	A	3.6	3.6	5.4	5.4	5.4
DC link capacitance						
	μF	15600	16800	18900	26100	28800
Pulse frequency ⁵⁾						
• Rated frequency	kHz	1.25	1.25	1.25	1.25	1.25
• Pulse frequency, max.						
- Without current derating	kHz	1.25	1.25	1.25	1.25	1.25
- With current derating	kHz	7.5	7.5	7.5	7.5	7.5
Power loss, max. ⁶⁾						
• At 50 Hz 400 V	kW	6.68	7.15	9.5	11.1	12.0
• At 60 Hz 460 V	kW	7.3	7.8	10.2	12.0	13.0
Cooling air requirement						
	m ³ /s	0.78	0.78	1.08	1.08	1.08
Sound pressure level L_{pA}						
(1 m) at 50/60 Hz	dB	72	72	72	72	72
Motor connection U2, V2, W2						
• Conductor cross section, max. (IEC)	mm ²	M12 screws 4 × 240	M12 screws 4 × 240	M12 screws 6 × 240	M12 screws 6 × 240	M12 screws 6 × 240
Cable length, max. ⁷⁾						
• Shielded	m	300	300	300	300	300
• Unshielded	m	450	450	450	450	450
PE/GND connection						
• Busbar cross-section	mm ²	PE bar 600	PE bar 600	PE bar 600	PE bar 600	PE bar 600
• Conductor cross section, max. (IEC)	mm ²	240	240	240	240	240
Degree of protection						
		IP20	IP20	IP20	IP20	IP20
Dimensions						
• Width ⁸⁾	mm	600	600	800	800	800
• Height ⁹⁾	mm	2200	2200	2200	2200	2200
• Depth	mm	600	600	600	600	600
Weight, approx.						
	kg	490	490	700	700	700
Frame size						
		HX	HX	JX	JX	JX
Short-circuit current rating acc. to IEC						
	kA	65	84	84	100	100

¹⁾ Rated output of a typical 6-pole standard induction motor based on I_L or I_H for 400 V 3 AC 50 Hz.

²⁾ Rated output of a typical 6-pole standard induction motor based on I_L or I_H for 460 V 3 AC 60 Hz.

³⁾ The base-load current I_L is based on a load cycle of 110 % for 60 s or 150 % for 10 s with a load cycle duration of 300 s.

⁴⁾ The base-load current I_H is based on a duty cycle of 150 % for 60 s or 160 % for 10 s with a duty cycle duration of 300 s.

⁵⁾ Information regarding the correlation between the pulse frequency and max. output current/output frequency is provided in the SINAMICS Low Voltage Engineering Manual.

⁶⁾ The specified power loss represents the maximum value at 100% utilization. The value is lower under normal operating conditions.

⁷⁾ Total of all motor cables. Longer cable lengths for specific configurations are available on request. For additional information, please refer to the SINAMICS Low Voltage Engineering Manual.

⁸⁾ With option **L10** (dv/dt filter plus VPL):
- Frame sizes FX/GX/HX/JX: Additional cabinet 600 mm wide
With option **L34** (circuit breaker on the output side):
- Frame size FX/GX: Additional cabinet 400 mm wide
- Frame size HX/JX: Additional cabinet 600 mm wide.

⁹⁾ The cabinet height increases by 250 mm with degree of protection IP21, and by 400 mm with degrees of protection IP23, IP43 and IP54.

Technical specifications (continued)

Line voltage 500 ... 690 V 3 AC		Motor Modules in chassis format					
DC link voltage 675 ... 1035 V DC		6SL3720-1TG28-5AA3	6SL3720-1TG31-0AA3	6SL3720-1TG31-2AA3	6SL3720-1TG31-5AA3	6SL3720-1TG31-8AA3	6SL3720-1TG32-2AA3
Type rating							
• At I_L (50 Hz 690 V) ¹⁾	kW	75	90	110	132	160	200
• At I_H (50 Hz 690 V) ¹⁾	kW	55	75	90	110	132	160
• At I_L (50 Hz 500 V) ¹⁾	kW	55	55	75	90	110	132
• At I_H (50 Hz 500 V) ¹⁾	kW	45	55	75	90	90	110
• At I_L (60 Hz 575 V) ²⁾	hp	75	75	100	150	150	200
• At I_H (60 Hz 575 V) ²⁾	hp	75	75	100	125	150	200
Output current							
• Rated current $I_{rated O}$	A	85	100	120	150	175	215
• Base-load current $I_L^{(3)}$	A	80	95	115	142	170	208
• Base-load current $I_H^{(4)}$	A	76	89	107	134	157	192
• Maximum current $I_{max O}$	A	120	142	172	213	255	312
DC link current							
• Rated current $I_{rated DC}$ when suppl. via							
- Basic/Smart Line Module	A	102	120	144	180	210	258
- Active Line Module	A	92	108	130	162	189	232
• Base-load current I_L^{DC} ³⁾ when supplied via							
- Basic/Smart Line Module	A	99	117	140	175	204	251
- Active Line Module	A	89	105	126	157	184	226
• Base-load current I_H^{DC} ⁴⁾ when supplied via							
- Basic/Smart Line Module	A	90	106	128	160	186	229
- Active Line Module	A	81	96	115	144	168	206
Current demand							
• 24 V DC auxiliary power supply	A	0.8	0.8	0.8	0.8	0.9	0.9
• 690 V AC	A	0.4	0.4	0.4	0.4	1.0	1.0
DC link capacitance	μF	1200	1200	1600	2800	2800	2800
Pulse frequency ⁵⁾							
• Rated frequency	kHz	1.25	1.25	1.25	1.25	1.25	1.25
• Pulse frequency, max.							
- Without current derating	kHz	1.25	1.25	1.25	1.25	1.25	1.25
- With current derating	kHz	7.5	7.5	7.5	7.5	7.5	7.5
Power loss, max. ⁶⁾							
• At 50 Hz 690 V	kW	1.17	1.43	1.89	1.8	2.67	3.09
• At 60 Hz 575 V	kW	1.1	1.3	1.77	1.62	2.5	2.91
Cooling air requirement	m ³ /s	0.17	0.17	0.17	0.17	0.36	0.36
Sound pressure level L_{pA} (1 m) at 50/60 Hz	dB	67	67	67	67	69	69
Motor connection U2, V2, W2							
• Conductor cross section, max. (IEC)	mm ²	M12 screws 2 x 185	M12 screws 2 x 185	M12 screws 2 x 185	M12 screws 2 x 185	M12 screws 2 x 240	M12 screws 2 x 240
Cable length, max. ⁷⁾							
• Shielded	m	300	300	300	300	300	300
• Unshielded	m	450	450	450	450	450	450
PE/GND connection							
• Busbar cross-section	mm ²	PE bar 600	PE bar 600	PE bar 600	PE bar 600	PE bar 600	PE bar 600
• Conductor cross section, max. (IEC)	mm ²	240	240	240	240	240	240
Degree of protection		IP20	IP20	IP20	IP20	IP20	IP20
Dimensions							
• Width ⁸⁾	mm	400	400	400	400	400	400
• Height ⁹⁾	mm	2200	2200	2200	2200	2200	2200
• Depth	mm	600	600	600	600	600	600
Weight, approx.	kg	145	145	145	145	286	286
Frame size		FX	FX	FX	FX	GX	GX
Short-circuit current rating acc. to IEC	kA	65	65	65	65	65	65

¹⁾ Rated output of a typical 6-pole standard induction motor based on I_L or I_H for 500 V or 690 V 3 AC 50 Hz.

²⁾ Rated output of a typical 6-pole standard induction motor based on I_L or I_H for 575 V 3 AC 60 Hz.

³⁾ The base-load current I_L is based on a load cycle of 110 % for 60 s or 150 % for 10 s with a load cycle duration of 300 s.

⁴⁾ The base-load current I_H is based on a duty cycle of 150 % for 60 s or 160 % for 10 s with a duty cycle duration of 300 s.

⁵⁾ Information regarding the correlation between the pulse frequency and max. output current/output frequency is provided in the SINAMICS Low Voltage Engineering Manual.

⁶⁾ The specified power loss represents the maximum value at 100% utilization. The value is lower under normal operating conditions.

⁷⁾ Total of all motor cables. Longer cable lengths for specific configurations are available on request. For additional information, please refer to the SINAMICS Low Voltage Engineering Manual.

⁸⁾ With option **L10** (dv/dt filter plus VPL):
- Frame sizes FX/GX/HX/JX: Additional cabinet 600 mm wide
With option **L34** (circuit breaker on the output side):
- Frame size FX/GX: Additional cabinet 400 mm wide
- Frame size HX/JX: Additional cabinet 600 mm wide.

⁹⁾ The cabinet height increases by 250 mm with degree of protection IP21, and by 400 mm with degrees of protection IP23, IP43 and IP54.

SINAMICS S120 Cabinet Modules

Air-cooled units

Motor Modules Chassis format

Technical specifications (continued)

Line voltage 500 ... 690 V 3 AC DC link voltage 675 ... 1035 V DC		Motor Modules in chassis format					
		6SL3720-1TG32-6AA3	6SL3720-1TG33-3AA3	6SL3720-1TG34-1AA3	6SL3720-1TG34-7AA3	6SL3720-1TG35-8AA3	6SL3720-1TG37-4AA3
Type rating							
• At I_L (50 Hz 690 V) ¹⁾	kW	250	315	400	450	560	710
• At I_H (50 Hz 690 V) ¹⁾	kW	200	250	315	400	450	630
• At I_L (50 Hz 500 V) ¹⁾	kW	160	200	250	315	400	500
• At I_H (50 Hz 500 V) ¹⁾	kW	132	160	200	250	315	450
• At I_L (60 Hz 575 V) ²⁾	hp	250	300	400	450	600	700
• At I_H (60 Hz 575 V) ²⁾	hp	200	250	350	450	500	700
Output current							
• Rated current $I_{rated O}$	A	260	330	410	465	575	735
• Base-load current $I_L^{(3)}$	A	250	320	400	452	560	710
• Base-load current $I_H^{(4)}$	A	233	280	367	416	514	657
• Maximum current $I_{max O}$	A	375	480	600	678	840	1065
DC link current							
• Rated current $I_{rated DC}$ when suppl. via	A						
- Basic/Smart Line Module	A	312	396	492	558	690	882
- Active Line Module	A	281	356	443	502	621	794
• Base-load current $I_{L DC}^{(3)}$ when supplied via	A						
- Basic/Smart Line Module	A	304	386	479	544	672	859
- Active Line Module	A	273	347	431	489	605	774
• Base-load current $I_{H DC}^{(4)}$ when supplied via	A						
- Basic/Smart Line Module	A	277	352	437	496	614	784
- Active Line Module	A	250	316	394	446	552	706
Current demand							
• 24 V DC auxiliary power supply	A	0.9	0.9	1.0	1.0	1.0	1.25
• 690 V AC	A	1.0	1.0	2.1	2.1	2.1	3.1
DC link capacitance		μF	3900	4200	7400	7400	11100
Pulse frequency ⁵⁾							
• Rated frequency	kHz	1.25	1.25	1.25	1.25	1.25	1.25
• Pulse frequency, max.							
- Without current derating	kHz	1.25	1.25	1.25	1.25	1.25	1.25
- With current derating	kHz	7.5	7.5	7.5	7.5	7.5	7.5
Power loss, max. ⁶⁾							
• At 50 Hz 690 V	kW	3.62	4.34	6.13	6.8	10.3	10.9
• At 60 Hz 575 V	kW	3.38	3.98	5.71	6.32	9.7	10.0
Cooling air requirement		m ³ /s	0.36	0.36	0.78	0.78	1.08
Sound pressure level L_{pA} (1 m) at 50/60 Hz		dB	69	69	72	72	72
Motor connection U2, V2, W2			M12 screws	M12 screws	M12 screws	M12 screws	M12 screws
• Conductor cross section, max. (IEC)	mm ²		2 × 240	2 × 240	4 × 240	4 × 240	6 × 240
Cable length, max. ⁷⁾							
• Shielded	m	300	300	300	300	300	300
• Unshielded	m	450	450	450	450	450	450
PE/GND connection			PE bar	PE bar	PE bar	PE bar	PE bar
• Busbar cross-section	mm ²		600	600	600	600	600
• Conductor cross section, max. (IEC)	mm ²		240	240	240	240	240
Degree of protection			IP20	IP20	IP20	IP20	IP20
Dimensions							
• Width ⁸⁾	mm	400	400	600	600	600	800
• Height ⁹⁾	mm	2200	2200	2200	2200	2200	2200
• Depth	mm	600	600	600	600	600	600
Weight, approx.		kg	286	286	490	490	700
Frame size			GX	GX	HX	HX	JX
Short-circuit current rating acc. to IEC		kA	65	65	65	84	100

¹⁾ Rated output of a typical 6-pole standard induction motor based on I_L or I_H for 500 V or 690 V 3 AC 50 Hz.

²⁾ Rated output of a typical 6-pole standard induction motor based on I_L or I_H for 575 V 3 AC 60 Hz.

³⁾ The base-load current I_L is based on a load cycle of 110 % for 60 s or 150 % for 10 s with a load cycle duration of 300 s.

⁴⁾ The base-load current I_H is based on a duty cycle of 150 % for 60 s or 160 % for 10 s with a duty cycle duration of 300 s.

⁵⁾ Information regarding the correlation between the pulse frequency and max. output current/output frequency is provided in the SINAMICS Low Voltage Engineering Manual.

⁶⁾ The specified power loss represents the maximum value at 100% utilization. The value is lower under normal operating conditions.

⁷⁾ Total of all motor cables. Longer cable lengths for specific configurations are available on request. For additional information, please refer to the SINAMICS Low Voltage Engineering Manual.

⁸⁾ With option **L10** (dv/dt filter plus VPL):
- Frame sizes FX/GX/HX/JX: Additional cabinet 600 mm wide
With option **L34** (circuit breaker on the output side):
- Frame size FX/GX: Additional cabinet 400 mm wide
- Frame size HX/JX: Additional cabinet 600 mm wide.

⁹⁾ The cabinet height increases by 250 mm with degree of protection IP21, and by 400 mm with degrees of protection IP23, IP43 and IP54.

Technical specifications (continued)

Line voltage 500 ... 690 V 3 AC		Motor Modules in chassis format				
DC link voltage 675 ... 1035 V DC		6SL3720-1TG38-1AA3	6SL3720-1TG38-8AA3	6SL3720-1TG41-0AA3	6SL3720-1TG41-3AA3	
Type rating						
• At I_L (50 Hz 690 V) ¹⁾	kW	800	900	1000	1200	
• At I_H (50 Hz 690 V) ¹⁾	kW	710	800	900	1000	
• At I_L (50 Hz 500 V) ¹⁾	kW	560	630	710	900	
• At I_H (50 Hz 500 V) ¹⁾	kW	500	560	630	800	
• At I_L (60 Hz 575 V) ²⁾	hp	800	900	1000	1250	
• At I_H (60 Hz 575 V) ²⁾	hp	700	800	900	1000	
Output current						
• Rated current $I_{rated O}$	A	810	910	1025	1270	
• Base-load current I_L ³⁾	A	790	880	1000	1230	
• Base-load current I_H ⁴⁾	A	724	814	917	1136	
• Maximum current $I_{max O}$	A	1185	1320	1500	1845	
DC link current						
• Rated current $I_{rated DC}$ when supplied via	A					
- Basic/Smart Line Module	A	972	1092	1230	1524	
- Active Line Module	A	875	983	1107	1372	
• Base-load current $I_{L DC}$ ³⁾ when supplied via	A					
- Basic/Smart Line Module	A	947	1064	1199	1485	
- Active Line Module	A	853	958	1079	1337	
• Base-load current $I_{H DC}$ ⁴⁾ when supplied via	A					
- Basic/Smart Line Module	A	865	971	1094	1356	
- Active Line Module	A	778	874	985	1221	
Current demand						
• 24 V DC auxiliary power supply	A	1.25	1.4	1.4	1.4	
• 690 V AC	A	3.1	3.1	3.1	3.1	
DC link capacitance		μF	11100	14400	14400	19200
Pulse frequency ⁵⁾						
• Rated frequency	kHz	1.25	1.25	1.25	1.25	
• Pulse frequency, max.						
- Without current derating	kHz	1.25	1.25	1.25	1.25	
- With current derating	kHz	7.5	7.5	7.5	7.5	
Power loss, max. ⁶⁾						
• At 50 Hz 690 V	kW	11.5	11.7	13.2	16.0	
• At 60 Hz 575 V	kW	10.5	10.6	12.0	14.2	
Cooling air requirement		m ³ /s	1.08	1.08	1.08	1.08
Sound pressure level L_{pA} (1 m) at 50/60 Hz		dB	72	72	72	72
Motor connection U2, V2, W2			M12 screws	M12 screws	M12 screws	M12 screws
• Conductor cross section, max. (IEC)	mm ²	6 x 240	6 x 240	6 x 240	6 x 240	
Cable length, max. ⁷⁾						
• Shielded	m	300	300	300	300	
• Unshielded	m	450	450	450	450	
PE/GND connection			PE bar	PE bar	PE bar	PE bar
• Busbar cross-section	mm ²	600	600	600	600	
• Conductor cross section, max. (IEC)	mm ²	240	240	240	240	
Degree of protection			IP20	IP20	IP20	IP20
Dimensions						
• Width ⁸⁾	mm	800	800	800	800	
• Height ⁹⁾	mm	2200	2200	2200	2200	
• Depth	mm	600	600	600	600	
Weight, approx.		kg	700	700	700	700
Frame size			JX	JX	JX	JX
Short-circuit current rating acc. to IEC		kA	100	100	100	100

¹⁾ Rated output of a typical 6-pole standard induction motor based on I_L or I_H for 500 V or 690 V 3 AC 50 Hz.

²⁾ Rated output of a typical 6-pole standard induction motor based on I_L or I_H for 575 V 3 AC 60 Hz.

³⁾ The base-load current I_L is based on a load cycle of 110 % for 60 s or 150 % for 10 s with a load cycle duration of 300 s.

⁴⁾ The base-load current I_H is based on a duty cycle of 150 % for 60 s or 160 % for 10 s with a duty cycle duration of 300 s.

⁵⁾ Information regarding the correlation between the pulse frequency and max. output current/output frequency is provided in the SINAMICS Low Voltage Engineering Manual.

⁶⁾ The specified power loss represents the maximum value at 100% utilization. The value is lower under normal operating conditions.

⁷⁾ Total of all motor cables. Longer cable lengths for specific configurations are available on request. For additional information, please refer to the SINAMICS Low Voltage Engineering Manual.

⁸⁾ With option **L10** (dv/dt filter plus VPL):
 - Frame sizes FX/GX/HX/JX: Additional cabinet 600 mm wide
 With option **L34** (circuit breaker on the output side):
 - Frame size FX/GX: Additional cabinet 400 mm wide
 - Frame size HX/JX: Additional cabinet 600 mm wide.

⁹⁾ The cabinet height increases by 250 mm with degree of protection IP21, and by 400 mm with degrees of protection IP23, IP43 and IP54.

SINAMICS S120 Cabinet Modules

Air-cooled units

Central Braking Modules

Overview



Central Braking Modules limit the DC link voltage at a central location in the drive line-up when the motors are operating in generator mode and energy recovery to the supply system is not possible. If, in regenerative mode, the voltage of the DC busbar exceeds a limit value, an externally installed braking resistor is switched in, thus restricting the voltage from increasing further. The regenerative energy is converted into heat. The braking resistor is switched in by the Braking Unit integrated in the Cabinet Module, which is equipped with state-of-the-art MOSFET/IGBT semiconductors.

Central Braking Modules are an alternative to the optional Braking Modules (options **L61/L62** or **L64/L65**) and are particularly suitable when high braking powers are required in a drive line-up. The required braking power can also be increased by connecting units in parallel.

Line voltage	DC link voltage	Braking power P_{150}
380 ... 480 V 3 AC	510 ... 720 V DC	500 kW/1000 kW
500 ... 600 V 3 AC	675 ... 900 V DC	550 kW/1100 kW
660 ... 690 V 3 AC	890 ... 1035 V DC	630 kW/1200 kW

The built-in fan means that Central Braking Modules are also suitable for high continuous power levels.

Design

The Central Braking Module is a cabinet unit with integrated braking chopper. Using state-of-the-art MOSFET/IGBT semiconductors, the power unit controls when the braking resistor is switched-in.

Central Braking Modules are designed as a 400 mm wide cabinet module. Its connection to the DC link is protected by fuses.

Central Braking Modules require braking resistors that must be externally mounted and which can be ordered separately. The cables to the resistors can be connected to lugs which are specially prepared for plant application and which are located in the connection area of the cabinet.

The power units have diagnostics LEDs for the display of faults and also a control output for the communication of faults. The Central Braking Module can be disabled externally via a control input.

The arrangement within the DC link grouping is subject to engineering rules.

For additional information, please refer to the [SINAMICS Low Voltage Engineering Manual](#).

Selection and ordering data

Braking powers				Central Braking Module
P_{15}	P_{150}	P_{270}	P_{DB}	Article No.
kW	kW	kW	kW	
DC link voltage 510 ... 720 V DC				
730	500	300	200	6SL3700-1AE35-0AA3
1380	1000	580	370	6SL3700-1AE41-0AA3
DC link voltage 675 ... 900 V DC				
830	550	340	220	6SL3700-1AF35-5AA3
1580	1100	650	420	6SL3700-1AF41-1AA3
DC link voltage 890 ... 1035 V DC				
920	630	380	240	6SL3700-1AH36-3AA3
1700	1200	720	460	6SL3700-1AH41-2AA3

Note:

In contrast to the optional Braking Modules (options **L61**, **L62** or **L64**, **L65**), the braking resistors for the Central Braking Modules must be ordered separately.

Braking power P_{150}	Dimensions (W × D × H)	Braking resistor in degree of protection IP21
kW	mm	Article No.
DC link voltage 510 ... 720 V DC		
500	960 × 620 × 790	6SL3000-1BE35-0AA0
1000	960 × 620 × 1430	6SL3000-1BE41-0AA0
DC link voltage 675 ... 900 V DC		
550	960 × 620 × 1110	6SL3000-1BF35-5AA0
1100	960 × 620 × 1430	6SL3000-1BF41-1AA0
DC link voltage 890 ... 1035 V DC		
630	960 × 620 × 1110	6SL3000-1BH36-3AA0
1200	960 × 620 × 1430	6SL3000-1BH41-2AA0

Integration

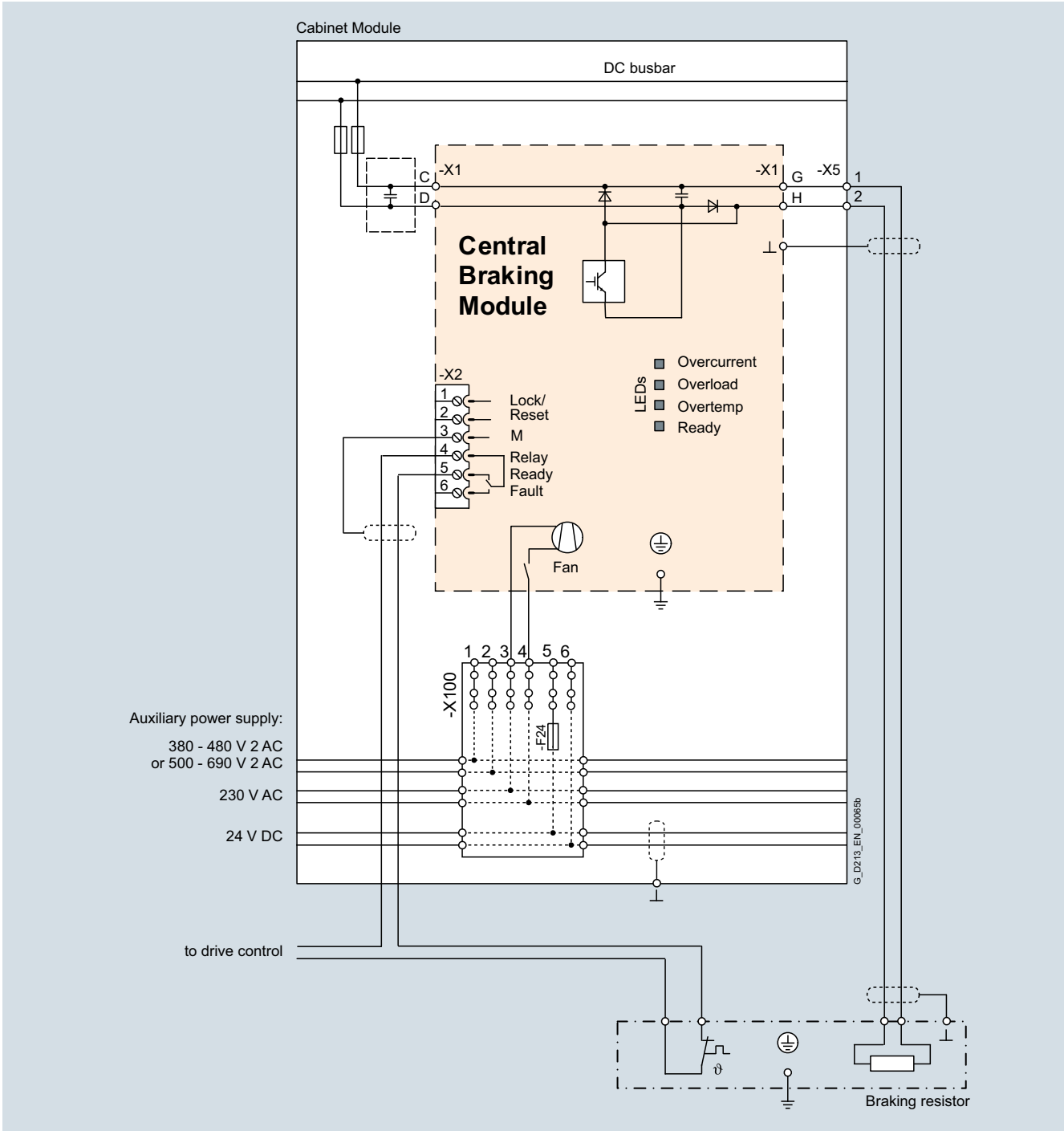

Example of connection of a Central Braking Module

SINAMICS S120 Cabinet Modules

Air-cooled units

Central Braking Modules

Technical specifications

	Central Braking Modules						
		6SL3700-1AE35-0AA3	6SL3700-1AE41-0AA3	6SL3700-1AF35-5AA3	6SL3700-1AF41-1AA3	6SL3700-1AH36-3AA3	6SL3700-1AH41-2AA3
Line voltage		380 ... 480 V		500 ... 600 V		660 ... 690 V	
Braking power P_{150}	kW	500	1000	550	1100	630	1200
Continuous braking power P_{DB}	kW	200	370	220	420	240	460
Braking current for P_{150}	A	650	1200	580	1100	520	1000
Current demand ¹⁾							
• 230 V 2 AC	A	0.4	0.4	0.4	0.4	0.4	0.4
Power loss, max. ²⁾ At 50 Hz 400/500/690 V	kW	0.8	1.5	0.8	1.5	0.8	1.5
DC link capacitance	μF	8160	9720	7640	8680	7640	8680
Cooling air requirement	m ³ /s	0.14	0.14	0.14	0.14	0.14	0.14
Sound pressure level L_{pA} (1 m) at 50/60 Hz	dB	55	55	55	55	55	55
Braking resistor connection		M12 screws	M12 screws	M12 screws	M12 screws	M12 screws	M12 screws
• Conductor cross section, max. (IEC)	mm ²	2 × 240	2 × 240	2 × 240	2 × 240	2 × 240	2 × 240
PE/GND connection		PE bar	PE bar	PE bar	PE bar	PE bar	PE bar
• Busbar cross-section	mm ²	600	600	600	600	600	600
• Conductor cross section, max. (IEC)	mm ²	240	240	240	240	240	240
Degree of protection		IP20	IP20	IP20	IP20	IP20	IP20
Dimensions							
• Width	mm	400	400	400	400	400	400
• Height ³⁾	mm	2200	2200	2200	2200	2200	2200
• Depth	mm	600	600	600	600	600	600
Weight, approx.	kg	230	230	230	230	230	230
Frame size	mm	400	400	400	400	400	400

	Braking resistors						
		6SL3000-1BE35-0AA0	6SL3000-1BE41-0AA0	6SL3000-1BF35-5AA0	6SL3000-1BF41-1AA0	6SL3000-1BH36-3AA0	6SL3000-1BH41-2AA0
Line voltage		380 ... 480 V		500 ... 600 V		660 ... 690 V	
Braking power P_{BR}	kW	500	1000	550	1100	630	1200
Continuous braking power P_{DB}	kW	23	58	34	62	42	75
Resistance value	Ω	0.95	0.49	1.35	0.69	1.8	0.95
Degree of protection		IP21	IP21	IP21	IP21	IP21	IP21
Dimensions							
• Width	mm	960	960	960	960	960	960
• Height	mm	620	620	620	620	620	620
• Depth	mm	790	1430	1110	1430	1110	1430
Weight, approx.	kg	82	170	110	180	124	196

¹⁾ Current demand of the fans.

²⁾ The specified power loss represents the maximum value at 100% utilization. The value is lower under normal operating conditions.

³⁾ The cabinet height increases by 250 mm with degree of protection IP21, and by 400 mm with degrees of protection IP23, IP43 and IP54.

Characteristic curves

Central Braking Modules are dimensioned for braking powers with the following duty cycles:

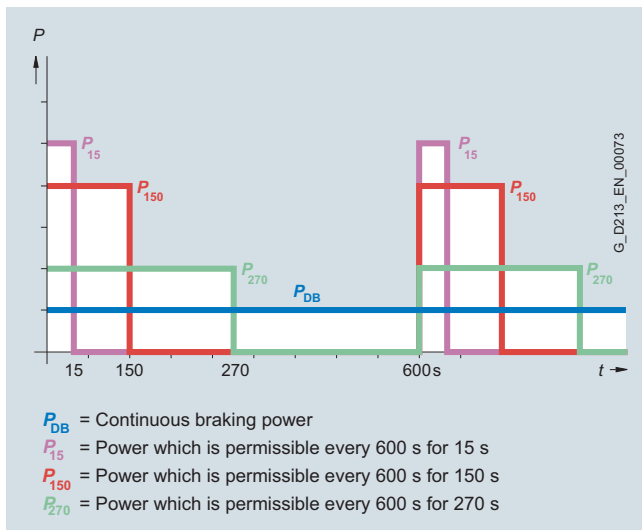

Braking powers of the Central Braking Modules

The braking powers are subject to a cycle time of 600 s. P_{150} is assumed to be the rated braking power. The braking resistors can be assigned according to these power ratings.

In most applications, Central Braking Modules are only used for occasional braking operations, e.g. stopping a drive in an emergency. Low-cost braking resistors in degree of protection IP21 are specifically offered for these types of applications; these braking resistors are dimensioned for braking powers P_{BR} with the following duty cycle:

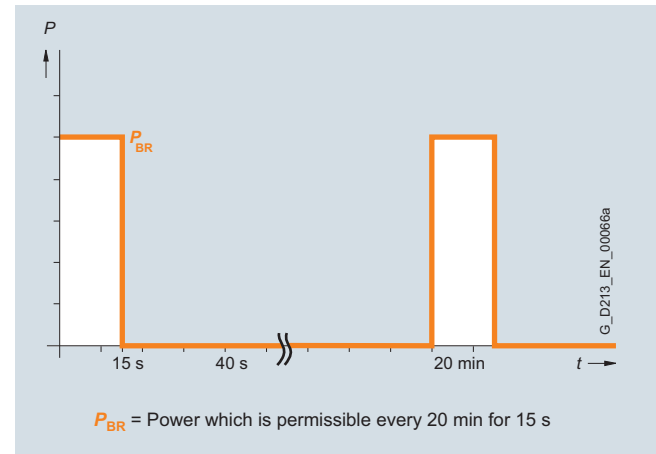

Duty cycle for braking resistors

Braking resistors with a higher braking power and shorter cycle times are available on request.

SINAMICS S120 Cabinet Modules

Air-cooled units

Auxiliary Power Supply Modules

Overview



Auxiliary Power Supply Modules supply the auxiliary power supply for the SINAMICS S120 Cabinet Modules. Units connected to this auxiliary power supply system include the fans of the SINAMICS S120 devices installed in the Cabinet Modules. In addition, the auxiliary power supply system supplies the electronic modules with an external voltage of 24 V DC. This is required when the DC link is not charged, for instance, in order to maintain PROFIBUS/PROFINET communication.

Selection and ordering data

System-side power supply (380 ... 690 V 3 AC)	Auxiliary Power Supply Module
A	Article No.
125	6SL3700-0MX14-0AA3
160	6SL3700-0MX16-3AA3
200	6SL3700-0MX21-0AA3
250	6SL3700-0MX21-4AA3

Note:

In smaller systems, there is often no need for an additional Cabinet Module for the auxiliary power supply. In such cases, the infeed for the auxiliary power supply system can also be supplied by the Line Connection Module. This must then be separately ordered (option **K76**).

4

Design

The Auxiliary Power Supply Module is connected in the customer's plant to a voltage corresponding to the respective rated unit voltage.

The standard version contains the following components:

- Fuse switch disconnecter with fuse monitoring for external evaluation
- Supply of the auxiliary power supply system with 3 fused auxiliary voltages:
 - 24 V DC for the electronics power supply
 - 230 V 2 AC to supply 230 V loads
 - 380 V to 690 V 2 AC to supply the equipment fans
- Transformer with 230 V output voltage
- SITOP 24 V DC power supply
- 6-pole auxiliary power supply system (ready-wired), including connections for looping through to the next Cabinet Module
- Nickel-plated PE busbar (60 mm × 10 mm), including jumper for looping through to the next Cabinet Module

Integration

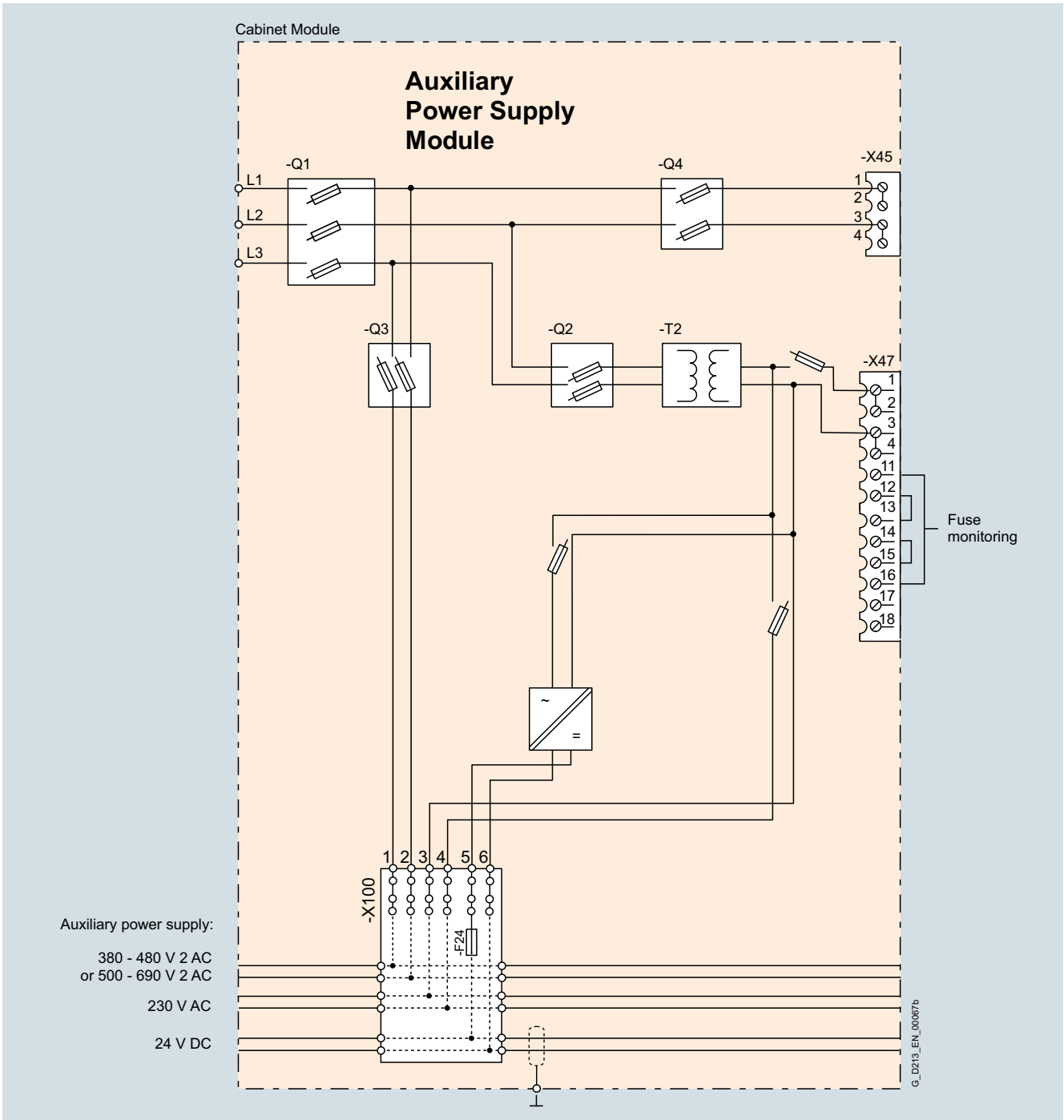

Block diagram: Auxiliary Power Supply Module

SINAMICS S120 Cabinet Modules

Air-cooled units

Auxiliary Power Supply Modules

Technical specifications

		Auxiliary Power Supply Modules			
		6SL3700-0MX14-0AA3	6SL3700-0MX16-3AA3	6SL3700-0MX21-0AA3	6SL3700-0MX21-4AA3
System-side power supply 380 ... 690 V 3 AC	A	125	160	200	250
Line supply connection • Conductor cross-section, max. (IEC)	mm ²	150	150	150	150
Max. current carrying capacity • Load connection 380 V ... 690 V AC - To auxiliary power supply - To customer terminal -X45	A A	63 50	80 63	100 80	100 80
• Load connection 230 V 2 AC - To auxiliary power supply - To customer terminal -X45	A A	6 8	10 10	10 10	20 20
• Load connection 24 V DC - To auxiliary power supply	A	20	40	80	80
Cable cross-section, max. • Connection -X45 • Connection -X47	mm ² mm ²	16 2.5	16 2.5	16 2.5	16 2.5
Cooling air requirement	m ³ /s	Natural convection	Natural convection	Natural convection	Natural convection
PE/GND connection • Busbar cross-section • Conductor cross section, max. (IEC)	mm ² mm ²	PE bar 600 240	PE bar 600 240	PE bar 600 240	PE bar 600 240
Degree of protection		IP20	IP20	IP20	IP20
Dimensions • Width • Height ¹⁾ • Depth	mm mm mm	600 2200 600	600 2200 600	600 2200 600	600 2200 600
Weight, approx.	kg	170	180	210	240
Minimum short-circuit current ²⁾	A	3200	4000	5000	7000

¹⁾ The cabinet height increases by 250 mm with degree of protection IP21, and by 400 mm with degrees of protection IP23, IP43 and IP54.

²⁾ Current required to ensure reliable tripping of installed protective devices.

Overview

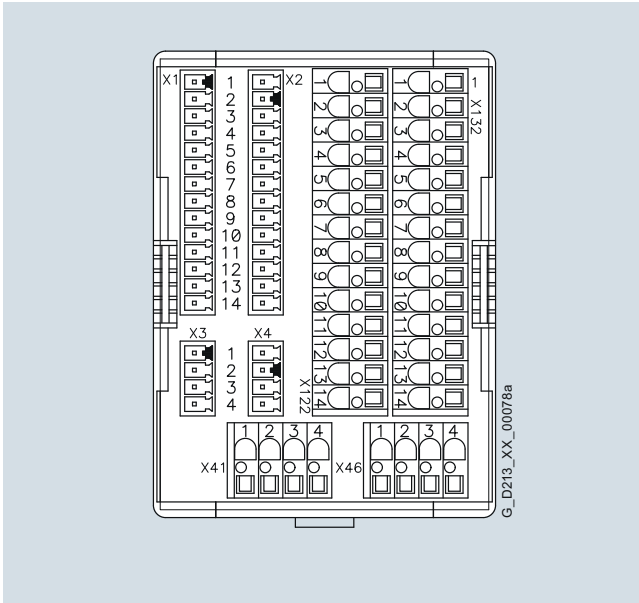

Customer terminal block -X55 is the interface with the I/O devices and marshals a range of cabinet-internal signals to a central terminal block module mounted in the lower part of the cabinet.

It can be used for Motor Modules in the chassis format as well as together with options **K90** (Control Unit CU320-2 DP) or **K95** (Control Unit CU320-2 PN) for Basic Line Modules, Smart Line Modules, Active Line Modules and Booksize Cabinet Kits.

Design

To connect signal cables on the customer side, terminal block -X55 includes terminals -X122, -X132, -X41 and -X46 (terminals -X1 to -X4 are used inside the cabinet and are not available). As a consequence, depending on the version (with/without option **K90**) the following digital inputs/outputs and/or signals are available:

The customer terminal strip -X55 includes:	Motor Modules in chassis format		Line Modules	
	Without CU320-2 (K90/K95)	With CU320-2 (K90/K95)	Without CU320-2 (K90/K95)	With CU320-2 (K90/K95)
-X122, -X132				
12 digital inputs DI	–	✓	–	✓
8 bidirectional inputs/outputs (DI/DO)	–	✓	–	✓
-X41				
Connection safety function Safe Torque Off / Safe Stop 1	✓	✓	– ¹⁾	– ¹⁾
Connection temperature sensor KTY84/PTC/Pt100	✓	✓	– ¹⁾	– ¹⁾
-X46				
Connection, Safe Brake Adapter	✓	✓	–	–

¹⁾ For Booksize Cabinet Kits, a connection is provided at the separate customer terminal block -X55.1.

SINAMICS S120 Cabinet Modules

Air-cooled units

Customer terminal block -X55

Design (continued)

Pin assignment

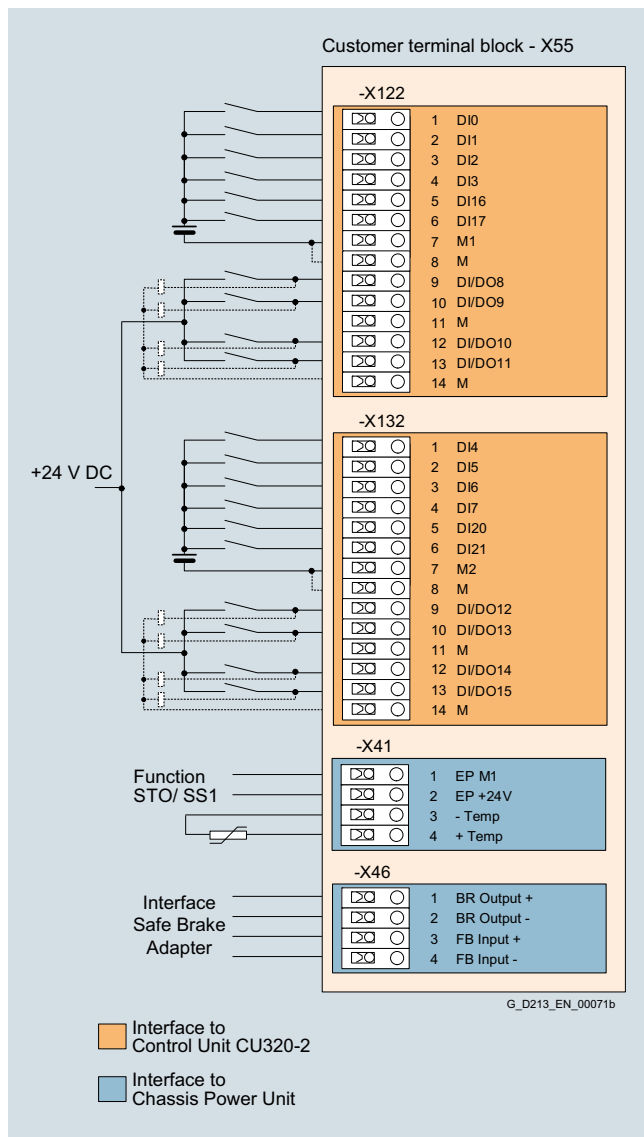

Terminal assignment of customer terminal block -X55

Terminal block -X55-X122 digital inputs/outputs

Terminal	Designation ¹⁾	Technical data
1	DI 0	Voltage -30 V to +30 V DC
2	DI 1	Current consumption, typical: 9 mA at 24 V DC
3	DI 2	Electrical isolation: The reference potential is terminal M1
4	DI 3	Level (incl. ripple)
5	DI 16	High level: 15 V ... 30 V
6	DI 17	Low level: -30 V ... +5 V
		Input delay (typ.): at 0 → 1: 50 μs at 1 → 0: 150 μs
7	M1	Reference potential for terminals 1 to 6
8	M	Ground
9	DI/DO 8	As input:
10	DI/DO 9	Voltage -30 V ... +30 V DC
11	M	Current consumption, typical: 9 mA at 24 V DC
12	DI/DO 10	Level (incl. ripple)
13	DI/DO 11	High level: 15 V ... 30 V Low level: -30 V ... +5 V
14	M	Fast inputs: ²⁾ DI/DO 8, 9, 10 and 11
		Input delay (typ.): at 0 → 1: 5 μs at 1 → 0: 50 μs
		As output:
		Voltage 24 V DC
		Max. load current per output: 500 mA continuously short-circuit proof
		Output delay (typ./max.): ³⁾ at 0 → 1: 150 μs/400 μs at 1 → 0: 75 μs/100 μs
		Switching frequency: For resistive load: max. 100 Hz For inductive load: max. 0.5 Hz For lamp load: max. 10 Hz Max. Lamp load: 5 W

Max. connectable cross-section: 2.5 mm²

¹⁾ DI: Digital input
DI/DO: Bidirectional digital input/output
M: Electronics ground
M1: Reference ground.

²⁾ Can be used as measuring probe input or input for the external zero mark.

³⁾ Data for: $U_{cc} = 24\text{ V}$; load $48\ \Omega$; High (1) = 90 % U_{out} ; Low (0) = 10 % U_{out} .

Design (continued)

Terminal block -X55-X132 digital inputs/outputs

Terminal	Designation ¹⁾	Technical data
1	DI 4	Voltage -30 V to +30 V DC Current consumption, typical: 9 mA at 24 V DC
2	DI 5	
3	DI 6	Electrical isolation: The reference potential is terminal M2
4	DI 7	
5	DI 20	Level (incl. ripple) High level: 15 V ... 30 V Low level: -30 V ... +5 V
6	DI 21	
		Input delay (typ.): at 0 → 1: 50 μs at 1 → 0: 150 μs
7	M2	Reference potential for terminals 1 to 6
8	M	Ground
9	DI/DO 12	<u>As input:</u>
10	DI/DO 13	Voltage -30 V ... +30 V DC Current consumption, typical: 9 mA at 24 V DC
11	M	
12	DI/DO 14	Level (incl. ripple) High level: 15 V ... 30 V Low level: -30 V ... +5 V
13	DI/DO 15	
14	M	Fast inputs: ²⁾ DI/DO 12, 13, 14 and 15
		Input delay (typ.): at 0 → 1: 5 μs at 1 → 0: 50 μs
		<u>As output:</u>
		Voltage 24 V DC Max. load current per output: 500 mA continuously short-circuit proof
		Output delay (typ./max.): ³⁾ at 0 → 1: 150 μs/400 μs at 1 → 0: 75 μs/100 μs
		Switching frequency: For resistive load: max. 100 Hz For inductive load: max. 0.5 Hz For lamp load: max. 10 Hz Max. Lamp load: 5 W

 Max. connectable cross-section: 2.5 mm²
Terminal block -X55-X41 temperature sensor connection

Terminal	Function	Technical data
1	EP M1 (enable pulses)	Supply voltage 24 V DC (20.4 ... 28.8 V) Current consumption: 10 mA
2	EP +24 V (enable pulses)	Signal propagation times: L → H: 100 μs H → L: 1000 μs The pulse inhibit function is only available when Safety Integrated Basic Functions are enabled
3	-Temp	Temperature sensor connection for motor temperature sensing:
4	+Temp	KTY84-1C130, PTC, Pt100

 Max. connectable cross-section: 2.5 mm²
Terminal block -X55-X46 brake control and monitoring

Terminal	Function	Technical data
1	BR output +	The interface is used to connect the Safe Brake Adapter
2	BR output -	
3	FB input +	
4	FB input -	

 Max. connectable cross-section: 2.5 mm²

¹⁾ DI: Digital input
DI/DO: Bidirectional digital input/output
M: Electronics ground
M2: Reference ground.

²⁾ Can be used as measuring probe input or input for the external zero mark.

³⁾ Data for: $U_{CC} = 24\text{ V}$; load $48\ \Omega$; High (1) = 90 % U_{out} ; Low (0) = 10 % U_{out} .

SINAMICS S120 Cabinet Modules

Liquid-cooled units

Liquid-cooled units

Overview

To comply with high requirements regarding installation and ambient conditions, SINAMICS S120 Cabinet Modules are also available in a liquid-cooled version.

The power loss of the units is transferred to the cooling liquid and dissipated, without noticeably increasing the temperature of the surrounding environment. As a consequence it is possible to save the expense of controlling the climate of the electrical room.

The system consists of liquid-cooled Basic Line Connection Module, Active Line Connection Modules, Motor Modules and a suitably selected cooling unit (Heat Exchanger Module).

Basic Line Connection Modules

Basic Line Connection Modules comprise a Line Connection Module and a liquid-cooled Basic Line Module. Basic Line Connection Modules are only suitable for infeed operation, i.e. they are not capable of feeding regenerative energy back into the supply system.

If regenerative energy is produced, e.g. when the drives brake, it must be converted into heat in external braking resistors using a supplementary Motor Module, which is used as Braking Module.

When a Basic Line Connection Module is used as the infeed, a line reactor appropriate for the supply conditions must be installed. If the infeed is realized via a transformer with an appropriate rating in 6-pulse operation with a Basic Line Connection Module or in 12-pulse operation with two Basic Line Connection Modules, the line reactor is optional and can be omitted.

If two or more Basic Line Connection Modules are operated in parallel on a common supply system in order to increase power, then line reactors must also be used.

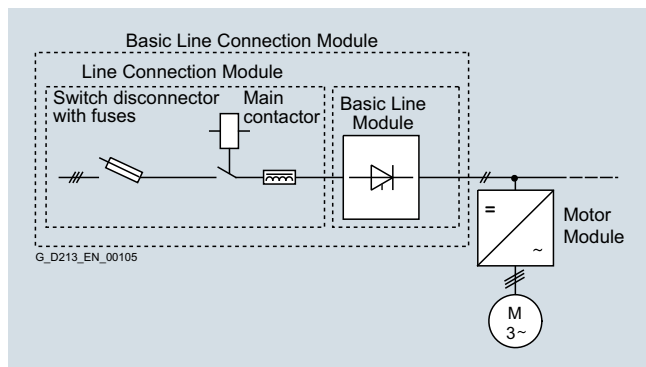

Basic Line Connection Module ≤ 800 A

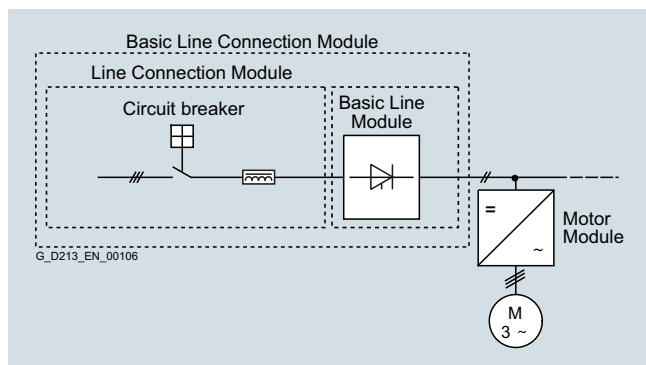

Basic Line Connection Module > 800 A

Active Line Connection Modules

Active Line Connection Modules comprise a Line Connection Module, a liquid-cooled Active Interface Module and a liquid-cooled Active Line Module. Active Line Connection Modules can supply energy to the DC link and return regenerative energy to the line supply (energy recovery). The use of an additional Motor Module as a Braking Module is only required if the drives need to be decelerated in a controlled manner after a power failure (i.e. when energy cannot be fed back into the line supply).

In contrast to Basic Line Connection Modules, Active Line Connection Modules generate a regulated DC voltage which remains constant irrespective of fluctuations in the line voltage. However, in this case, the line voltage must remain within the permissible tolerance range. Active Line Connection Modules draw a virtually sinusoidal current from the supply which limits any damaging current harmonics.

Active Line Connection Modules always contain an Active Interface Module, which in addition to a Clean Power Filter, also includes the necessary precharging circuit for the Active Line Module.

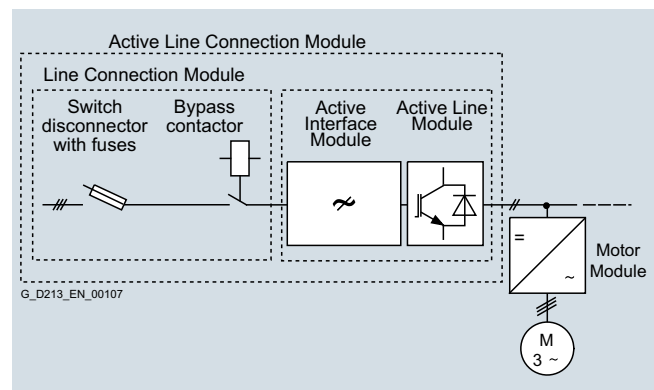

Active Line Connection Module with Active Interface Module and Active Line Module ≤ 800 A

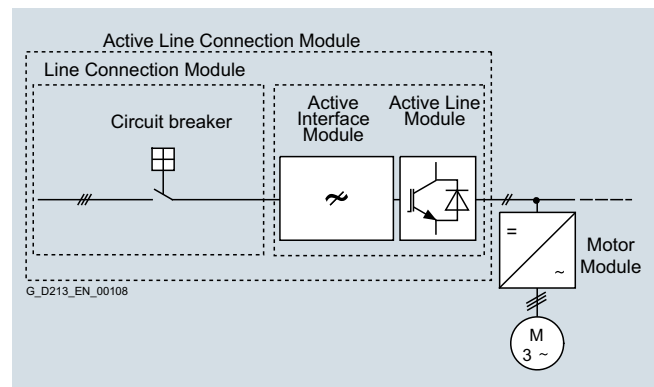

Active Line Connection Module with Active Interface Module and Active Line Module > 800 A

Motor Modules

Each Cabinet Module is fitted with one SINAMICS S120 Motor Module in chassis format and covers the power range from 315 kW to 1500 kW (380 V to 480 V or 500 V to 690 V). The power rating can be extended up to approx. 5700 kW by connection in parallel.

The Motor Modules can also be used as Braking Modules (braking chopper) if a 3-phase braking resistor is connected instead of a motor.

For more detailed information on this topic, please refer to the [SINAMICS Low Voltage Engineering Manual](#).

Technical specifications

General technical specifications

Electrical specifications			
Line voltages	380 ... 480 V 3 AC, ±10 % (-15 % <1 min) 500 ... 690 V 3 AC, ±10 % (-15 % <1 min)		
Line supply types	Grounded TN/TT systems and non-grounded IT systems		
Line frequency	47 ... 63 Hz		
Output frequency ¹⁾	0 ... 550 Hz		
• Control type Servo	0 ... 550 Hz		
• Control type Vector	0 ... 550 Hz		
• Control mode V/f	0 ... 550 Hz		
Line power factor	>0.96		
Fundamental	Adjustable (factory-set to $\cos \varphi = 1$)		
• Basic Line Module	>0.96		
• Active Line Module	Adjustable (factory-set to $\cos \varphi = 1$)		
Efficiency	>99 %		
• Basic Line Module	>99 %		
• Active Line Module	>97.5 % (including Active Interface Module)		
• Motor Module	>98.5 %		
Overvoltage category	III to EN 61800-5-1		
Control method	Vector/servo control with and without encoder or V/f control		
Fixed speeds	15 fixed speeds plus 1 minimum speed, parameterizable (in the default setting, 3 fixed setpoints plus 1 minimum speed are selectable using terminal block/PROFIBUS/PROFINET)		
Skippable speed ranges	4, parameterizable		
Setpoint resolution	0.001 rpm digital (14 bits + sign) 12 bits analog		
Braking operation	With Active Line Modules, four-quadrant operation as standard (energy recovery). With Basic Line Modules, two-quadrant operation as standard, braking by means of a Motor Module.		
Cabinet system			
Cabinet system	Rittal TS 8, doors with double-barb lock, base plate with cable entry options		
Paint finish	RAL 7035 (indoor requirements)		
Mechanical specifications			
Degree of protection	IP21 (higher degrees of protection up to IP55 optional)		
Protection class	I acc. to EN 61800-5-1		
Touch protection	EN 50274/BGV A3 for the intended purpose		
Cooling method	Cooling in compliance with EN 60146: Basic Line Connection Modules, Active Line Connection Modules, Motor Modules: WE - W: Liquid cooling - E: Forced air cooling, drive device outside the equipment Line reactors, motor reactors, dv/dt filters with Voltage Peak Limiter: AN - A: Air cooling - N: Natural cooling (convection)		
Ambient conditions	Storage ²⁾	Transport ²⁾	Operation
Ambient temperature	-25 ... +55 °C	-25 ... +70 °C from <u>-40 °C</u> for 24 hours	0 ... +40 °C <u>to</u> +50 °C, see derating data
Relative humidity (condensation not permissible)	5 ... 95 % Class 1K4 to IEC 60721-3-1	5 ... 95 % at 40 °C Class 2K3 acc. to IEC 60721-3-2	5 ... 95 % Class 3K3 acc. to IEC 60721-3-3
Environmental class/ harmful chemical substances	Class 1C2 acc. to EN 60721-3-1	Class 2C2 acc. to EN 60721-3-2	Class 3C2 acc. to EN 60721-3-3
Organic/biological influences	Class 1B1 acc. to EN 60721-3-1	Class 2B1 acc. to EN 60721-3-2	Class 3B1 acc. to EN 60721-3-3
Degree of pollution	2 acc. to EN 61800-5-1		
Installation altitude	≤ 2000 m above sea level without derating; > 2000 m, see derating data		
Mechanical stability	Storage ²⁾	Transport ²⁾	Operation
Vibration load	Class 1M2 acc. to EN 60721-3-1	Class 2M2 acc. to EN 60721-3-2	–
• Deflection	1.5 mm at <u>5</u> ... 9 Hz	3.1 mm at <u>5</u> ... 9 Hz	0.075 mm at 10 ... 58 Hz
• Acceleration	5 m/s ² at >9 ... 200 Hz	10 m/s ² at >9 ... 200 Hz	9.8 m/s ² at >58 ... 200 Hz
Shock load	Class 1M2 acc. to EN 60721-3-1	Class 2M2 acc. to EN 60721-3-2	Class 3M4 acc. to EN 60721-3-3
• Acceleration	40 m/s ² at 22 ms	100 m/s ² at 11 ms	100 m/s ² at 11 ms
Compliance with standards			
Conformances/approvals, acc. to	CE (EMC Directive No. 2004/108/EC and Low Voltage Directive No. 2006/95/EC and Machinery Directive 2006/42/EC for functional safety)		
Radio interference suppression	SINAMICS drive converter systems are not designed for connection to the public grid (first environment). Radio interference suppression is compliant with the EMC product standard for variable-speed drives EN 61800-3, "Second environment" (industrial networks). EMC disturbances can occur when connected to the public power networks.		

Deviations from the specified class are underlined.

¹⁾ Higher output frequencies available on request.

²⁾ In transport packaging.

SINAMICS S120 Cabinet Modules

Liquid-cooled units

Liquid-cooled units

Technical specifications (continued)

Cooling circuit and coolant quality

The following tables and sections describe the coolant quality requirements for the raw water circuit on the plant side and the deionized water circuit of the liquid-cooled SINAMICS S120 Cabinet Modules on the converter side.

Plant-side raw water circuit (based on VDI 3803)

• System pressure with reference to atmospheric pressure, max.	600 kPa
• Inlet temperature of liquid coolant	Anti-freeze essential for temperature range between 0 °C and 5 °C
- Degree of protection <IP55	0 ... 38 °C without derating >38 ... 43 °C, see derating characteristics
- Degree of protection IP55	0 ... 33 °C without derating >33 ... 38 °C, see derating characteristics

Coolant quality

• Electrical conductivity	< 2200 µS/cm
• pH value	7.5 ... 9
• Chloride ions	< 180 mg/l
• Sulfate ions	<200 mg/l
• Orthophosphate	< 50 mg/l
• Dissolved iron	< 3 mg/l
• Dissolved copper	< 0.2 mg/l
• Biological load	< 50 CFU/ml
• SiO ₂ as silicic acid	< 47 mg/l
• Aluminum	< 2.65 mg/l
• Fluoride	< 4 mg/l
• Total hardness	< 20 (< 40 °C) °dH
• Size of entrained particles	≤ 0.5 mm
• SK 4.3 (upper limit value of polymer phosphates for untreated additional water)	< 10 mmol/l
• Permissible limit values for suspended particles in the coolant	No deposits of solid particles at ≥ 0.5 m/s

Converter-side deionized water circuit

• System pressure with reference to atmospheric pressure, max.	600 kPa
• Pressure drop at rated volumetric flow	70 kPa
• Recommended pressure range	80 ... 200 kPa
• Inlet temperature of liquid coolant	Dependent on ambient temperature, no condensation permitted Anti-freeze essential for temperature range between 0 °C and 5 °C
- Degree of protection <IP55	0 ... 45 °C without derating >45 ... 50 °C, see derating characteristics
- Degree of protection IP55	0 ... 40 °C without derating >40 ... 45 °C, see derating characteristics

Coolant quality

• Coolant basis	Deionized water with reduced electrical conductivity according to ISO 3696, quality 3
• Electrical conductivity	<5 µS/cm (0.5 mS/m)
• pH value	5 ... 7.5
• Components that can be oxidized as oxygen content	<0.4 mg/l
• Residue after vaporization and drying at 110 °C	<2 mg/kg

The coolant definition specified here should only be considered as recommendation. For units that have been shipped, the information and data provided in the equipment manual supplied should be observed!

Anti-freeze

Anti-freeze	Antifrogen N	Antifrogen L	Varidos FSK
Manufacturer	Clariant	Clariant	Nalco
Chemical base	Monoethylene glycol	Propylene glycol	Monoethylene glycol
Minimum concentration	20 %	25 %	25 %
Anti-freeze agent with minimum concentration	-10 °C	-10 °C	-10 °C
Maximum concentration	45 %	48 %	45 %
Anti-freeze agent with maximum concentration	-30 °C	-30 °C	-30 °C
Inhibitor content	Contains inhibitors with nitrites	Contains inhibitors that are free of nitrates, amines, borates, and phosphate	Contains inhibitors that are free of nitrates, amines, borates, and phosphate
Biocide action with a concentration of	> 20 %	> 30 %	> 30 %

Biocides prevent corrosion that is caused by slime-forming, corrosive or iron-depositing bacteria. These can occur in closed cooling circuits with low water hardness and in open cooling circuits. Biocides must always be selected according to the relevant bacterial risks. Compatibility with inhibitors or anti-freeze used with them must be checked on a case-by-case basis.

Technical specifications (continued)

Protection against condensation

With liquid-cooled units, warm air can condense on the cold surfaces of heat sinks, pipes and hoses. This condensation depends on the air humidity and the temperature difference between the ambient air and the coolant.

The water which is produced as a result of condensation can cause corrosion as well as electrical damage such as creepage shorts and flashovers. Since SINAMICS units cannot prevent condensation when it is caused by the prevailing climatic conditions, measures must be implemented in the system configuration or in the customer's installation in order to preclude the risk of condensation. These measures include the following:

- a fixed coolant temperature that has been adjusted to the expected air humidity or ambient temperature ensures that critical differences between the coolant and ambient air temperatures do not develop or
- temperature regulation of the coolant as a function of the ambient air temperature

The temperature at which water vapor contained in the air condenses into water is known as the dew point. In order to reliably prevent condensation, the coolant temperature must always be higher than the dew point.

The table below specifies the dew point as a function of room temperature T and relative air humidity Φ for an atmospheric pressure of 100 kPa (1 bar). This corresponds to an installation altitude of 0 to approximately 500 m above sea level. Since the dew point drops as the air pressure decreases, the dew point values at higher installation altitudes are lower than the specified table values. It is therefore the safest approach to engineer the coolant temperature according to the table values for an installation altitude of zero.

Room temperature T	Relative air humidity Φ										
	20 %	30 %	40 %	50 %	60 %	70 %	80 %	85 %	90 %	95 %	100 %
10 °C	<0 °C	<0 °C	<0 °C	0.2 °C	2.7 °C	4.8 °C	6.7 °C	7.6 °C	8.4 °C	9.2 °C	10 °C
20 °C	<0 °C	2 °C	6 °C	9.3 °C	12 °C	14.3 °C	16.4 °C	17.4 °C	18.3 °C	19.1 °C	20 °C
25 °C	0.6 °C	6.3 °C	10.5 °C	13.8 °C	16.7 °C	19.1 °C	21.2 °C	22.2 °C	23.2 °C	24.1 °C	24.9 °C
30 °C	4.7 °C	10.5 °C	14.9 °C	18.4 °C	21.3 °C	23.8 °C	26.1 °C	27.1 °C	28.1 °C	29 °C	29.9 °C
35 °C	8.7 °C	14.8 °C	19.3 °C	22.9 °C	26 °C	28.6 °C	30.9 °C	32 °C	33 °C	34 °C	34.9 °C
40 °C	12.8 °C	19.1 °C	23.7 °C	27.5 °C	30.6 °C	33.4 °C	35.8 °C	36.9 °C	37.9 °C	38.9 °C	39.9 °C
45 °C	16.8 °C	23.3 °C	28.2 °C	32 °C	35.3 °C	38.1 °C	40.6 °C	41.8 °C	42.9 °C	43.9 °C	44.9 °C
50 °C	20.8 °C	27.5 °C	32.6 °C	36.6 °C	40 °C	42.9 °C	45.5 °C	46.6 °C	47.8 °C	48.9 °C	49.9 °C

A detailed description of the cooling circuits and the recommended coolant is given in the SINAMICS Low Voltage Engineering Manual.

SINAMICS S120 Cabinet Modules

Liquid-cooled units

Liquid-cooled units

Characteristic curves

Derating

Liquid-cooled SINAMICS S120 Cabinet Modules are rated for an ambient temperature of 45 °C and installation altitudes up to 2000 m above sea level and a plant-side raw water temperature of 38 °C (<IP55) or 33 °C (IP55). At ambient temperatures > 45 °C and a plant-side raw water temperature > 38 °C (<IP55) or 33 °C (IP55), the output current must be reduced. Ambient temperatures above 50 °C are not permissible. At installation altitudes > 2000 m above sea level, it must be taken into account that the air pressure, and therefore air density, decreases as the height increases. As a consequence, the cooling efficiency and the insulation capacity of the air also decrease.

The intake temperatures in the plant/system side raw water circuit must always be at least 7 K below the intake temperatures in the converter-side deionized water circuit. This ensures that the cooling power of the Heat Exchanger Module of the deionized water circuit, specified in the technical data, can be dissipated to the raw water circuit.

For additional information, please refer to the [SINAMICS Low Voltage Engineering Manual](#).

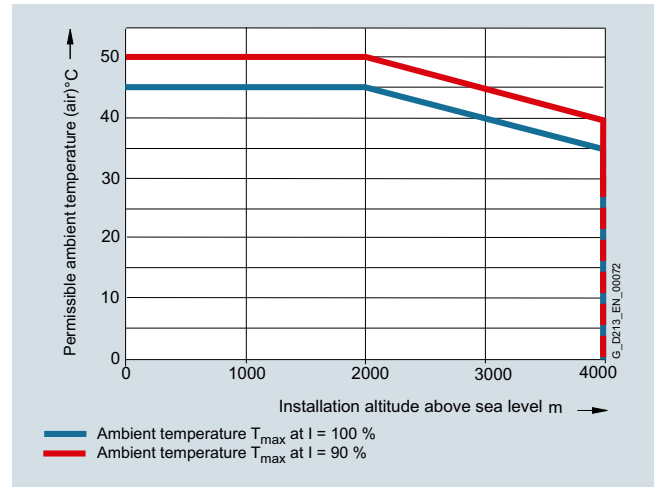

Permissible ambient temperature as a function of installation altitude

4

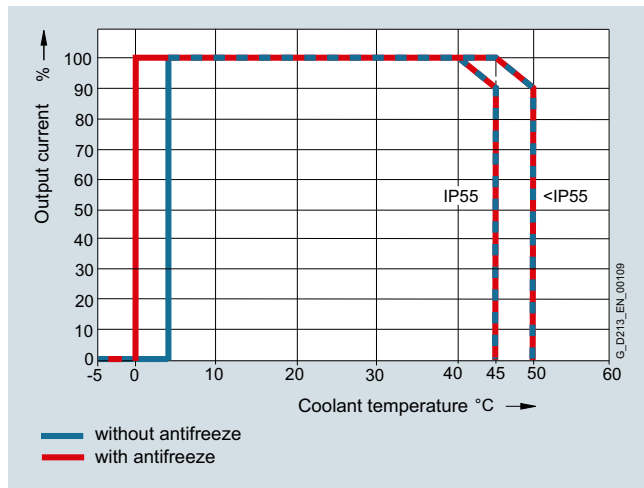

Current derating as a function of the temperature of the cooling liquid in the converter-side deionized water circuit ¹⁾

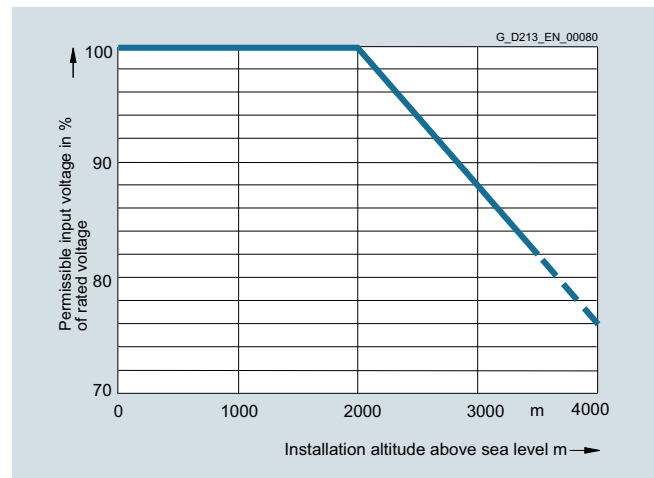

Voltage derating as a function of installation altitude

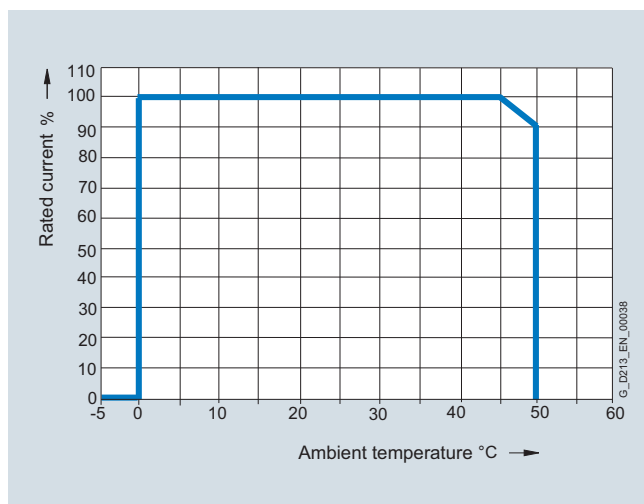

Current derating as a function of ambient temperature ¹⁾

¹⁾ The factors of the two derating curves must not be multiplied. The highest value in each case must be assumed for the purposes of calculation, so that the derating factor in the worst-case scenario is 0.9.

Characteristic curves (continued)

Current derating depending on the pulse frequency

To reduce motor noise or to increase output frequency, the pulse frequency can be increased relative to the factory setting (1.25 kHz or 2 kHz). When the pulse frequency is increased, the derating factor of the output current must be taken into account. This derating factor must be applied to the currents specified in the technical data.

For additional information, please refer to the SINAMICS Low Voltage Engineering Manual.

The following table lists the rated output currents of the Motor Modules with pulse frequency set at the factory as well as the current derating factors (permissible output currents referred to the rated output current) for higher pulse frequencies.

Derating factor of the output current as a function of the pulse frequency for units with a rated pulse frequency of 2 kHz

Motor Module	Type rating at 400 V kW	Output current at 2 kHz A	Derating factor at pulse frequency				
			2.5 kHz	4 kHz	5 kHz	7.5 kHz	8 kHz
380 ... 480 V 3 AC / 510 ... 720 V DC							
1TE41-4AS3	800	1330	88 %	55 %	–	–	–

Derating factor of the output current as a function of the pulse frequency for units with a rated pulse frequency of 1.25 kHz

Motor Module	Type rating at 400 V or 690 V kW	Output current at 1.25 kHz A	Derating factor at pulse frequency				
			2 kHz	2.5 kHz	4 kHz	5 kHz	7.5 kHz
380 ... 480 V 3 AC / 510 ... 720							
1TE36-1AA3	315	605	83 %	72 %	64 %	60 %	40 %
1TE37-5AA3	400	745	83 %	72 %	64 %	60 %	40 %
1TE38-4AA3	450	840	87 %	79 %	64 %	60 %	40 %
1TE41-0AA3	560	985	92 %	87 %	70 %	60 %	50 %
1TE41-2AA3	710	1260	92 %	87 %	70 %	60 %	50 %
1TE41-4AA3	800	1405	97 %	95 %	74 %	60 %	50 %
500 ... 690 V 3 AC / 675 ... 1035 V DC							
1TG35-8AA3	560	575	91 %	85 %	64 %	50 %	35 %
1TG37-4AA3	710	735	84 %	74 %	53 %	40 %	25 %
1TG38-0AA3	800 ¹⁾	810	82 %	71 %	52 %	40 %	25 %
1TG38-1AA3	800	810	97 %	95 %	71 %	55 %	35 %
1TG41-0AA3	1000	1025	91 %	86 %	64 %	50 %	30 %
1TG41-3AA3	1200	1270	87 %	79 %	55 %	40 %	25 %
1TG41-6AA3	1500	1560	87 %	79 %	55 %	40 %	25 %

The following tables list the maximum achievable output frequency as a function of the pulse frequency.

Maximum output frequencies achieved by increasing the pulse frequency in Vector mode

Pulse frequency	Max. achievable output frequency
1.25 kHz	100 Hz
2 kHz	160 Hz
2.5 kHz	200 Hz
4 kHz	320 Hz
5 kHz	400 Hz

Maximum output frequencies achieved by increasing the pulse frequency in Servo mode

Pulse frequency	Max. achievable output frequency
2 kHz	300 Hz
4 kHz	300/550 Hz ²⁾

¹⁾ The Motor Module 6SL3725-1TG38-0AA3 is optimized for low overload; with an increased pulse frequency, the derating factor is higher than for the Motor Module 6SL3725-1TG38-1AA3.

²⁾ Higher frequencies on request.

SINAMICS S120 Cabinet Modules

Liquid-cooled units

Liquid-cooled units

Characteristic curves (continued)

Overload capability

SINAMICS S120 Cabinet Modules have an overload reserve, e.g. to handle breakaway torques. If larger surge loads occur, this must be taken into account when configuring. For drives with overload requirements, the appropriate base load current must, therefore, be used as a basis for the required load.

Permissible overload assumes that the drive converter is operated at its base-load current before and after the overload occurs, based on a duty cycle duration of 300 s.

For temporary, periodic duty cycles with high variations of load within the duty cycle, the relevant sections of the SINAMICS Low Voltage Engineering Manual must be observed.

Motor Modules

Motor Modules can be configured on the basis of different base load currents.

The base-load current for a low overload I_L is the basis for a duty cycle of 110 % for 60 s or 150 % for 10 s.

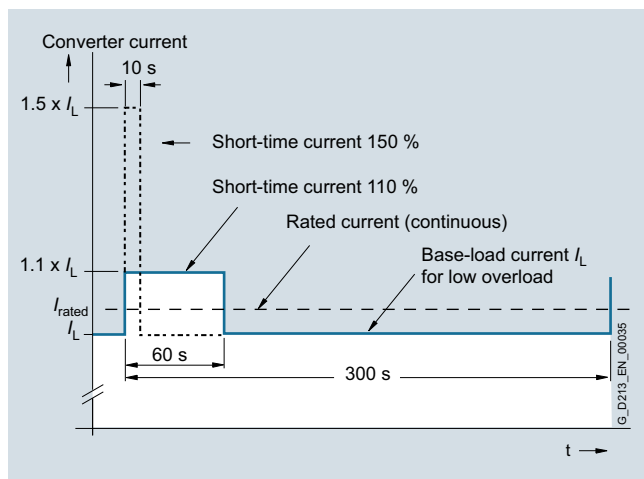

Low overload

The base-load current I_H for a high overload is based on a load cycle of 150 % for 60 s or 160 % for 10 s.

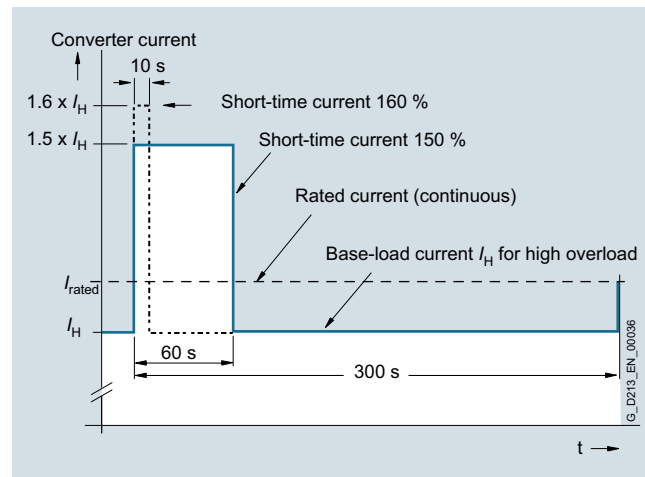

High overload

Basic Line Connection Modules and Active Line Connection Modules

The base-load current for a high overload I_{HDC} is the basis for a duty cycle of 150 % for 60 s or I_{maxDC} for 5 s.

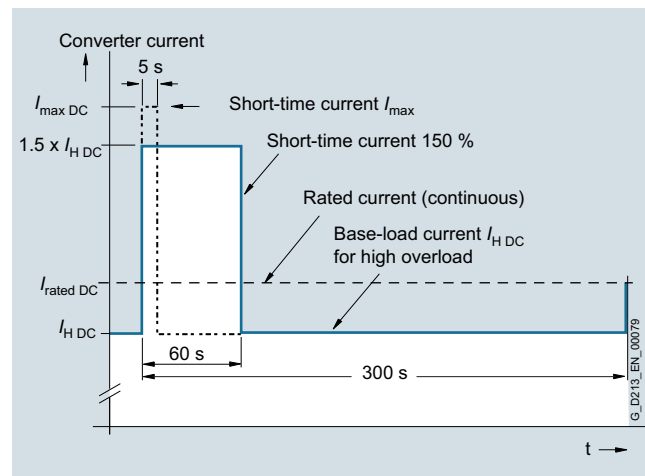

High overload

Overview



Basic Line Connection Modules are compact line infeeds for two-quadrant operation, i.e. no regenerative feedback. They are used when energy need not be fed back into the network.

Basic Line Connection Modules comprise a Line Connection Module and a liquid-cooled Basic Line Module.

As standard, the Basic Line Connection Module is positioned in the drive lineup so that the Motor Modules are arranged to the right. If Motor Modules are to be arranged to the left of the Basic Line Connection Module, option **M88** (DC bus system for line-side Cabinet Modules) must be ordered.

Line Connection Modules contain the line-side infeed via main breaker with fuse switch disconnecter or circuit breaker and establish the connection between the plant power system and the Basic Line Modules. It is equipped as standard with a radio interference suppression filter according to EN 61800-3 Category C3.

Under full load, the DC link voltage is higher than the rms value of the rated line voltage by a factor of 1.32, and under partial load by a factor of 1.35.

If regenerative conditions occur in the drive line-up, a Motor Module can be used as braking chopper, which then converts excess energy to heat in a braking resistor.

Basic Line Connection Modules are suitable for connection to grounded TN/TT and non-grounded IT systems. The following voltages and power ratings are available:

Line voltage	Rated input current	Rated power
380 ... 480 V 3 AC	610 ... 1420 A	360 ... 830 kW
500 ... 690 V 3 AC	340 ... 1350 A	355 ... 1370 kW

For a Basic Line Connection Module a line reactor should be provided at the connection point depending on the line short-circuit power. This reactor is available as standard. However, it can be omitted if it is not required (option **L22**).

Further information can be found in the [SINAMICS Low Voltage Engineering Manual](#).

Design

Depending on the input current, the following versions are available:

- ≤ 800 A: Main circuit breaker with fuse switch disconnecter
- > 800 A: Circuit breaker, type 3WL, with option **L25** as withdrawable circuit breaker

A fully controlled thyristor bridge is used to pre-charge the Basic Line Connection Module and the connected DC link. The thyristors normally operate with a trigger delay angle of 0°.

The power rating can be increased by connecting Basic Line Connection Modules in parallel. You must observe the following rules:

- Up to four identical Basic Line Connection Modules can be connected in parallel.
- A common Control Unit is required whenever the modules are connected in parallel.
- The parallel connection must be supplied from a common infeed point (i.e. the modules cannot be operated on different line supplies). For information on using line reactors, see [section Basic Line Connection Modules → Overview](#).
- A derating factor of 7.5% must be taken into consideration, regardless of the number of modules connected in parallel.
- The main contactors or circuit breakers of the respective Line Connection Modules must close together and simultaneously. Monitoring is performed via the -X50 terminals of the respective Line Connection Module.
- Option **M88** must be ordered.

For additional information, please refer to the [SINAMICS Low Voltage Engineering Manual](#).

Selection and ordering data

Rated power at 400 V or 690 V kW	Rated DC link current A	Basic Line Connection Module Article No.
Line voltage 380 ... 480 V 3 AC (DC link voltage 510 ... 650 V DC)		
360	740	6SL3735-1TE37-4LA3
600	1220	6SL3735-1TE41-2LA3
830	1730	6SL3735-1TE41-7LA3
Line voltage 500 ... 690 V 3 AC (DC link voltage 675 ... 930 V DC)		
355	420	6SL3735-1TG34-2LA3
630	730	6SL3735-1TG37-3LA3
1100	1300	6SL3735-1TG41-3LA3
1370	1650	6SL3735-1TG41-7LA3

SINAMICS S120 Cabinet Modules

Liquid-cooled units

Basic Line Connection Modules

Integration

4

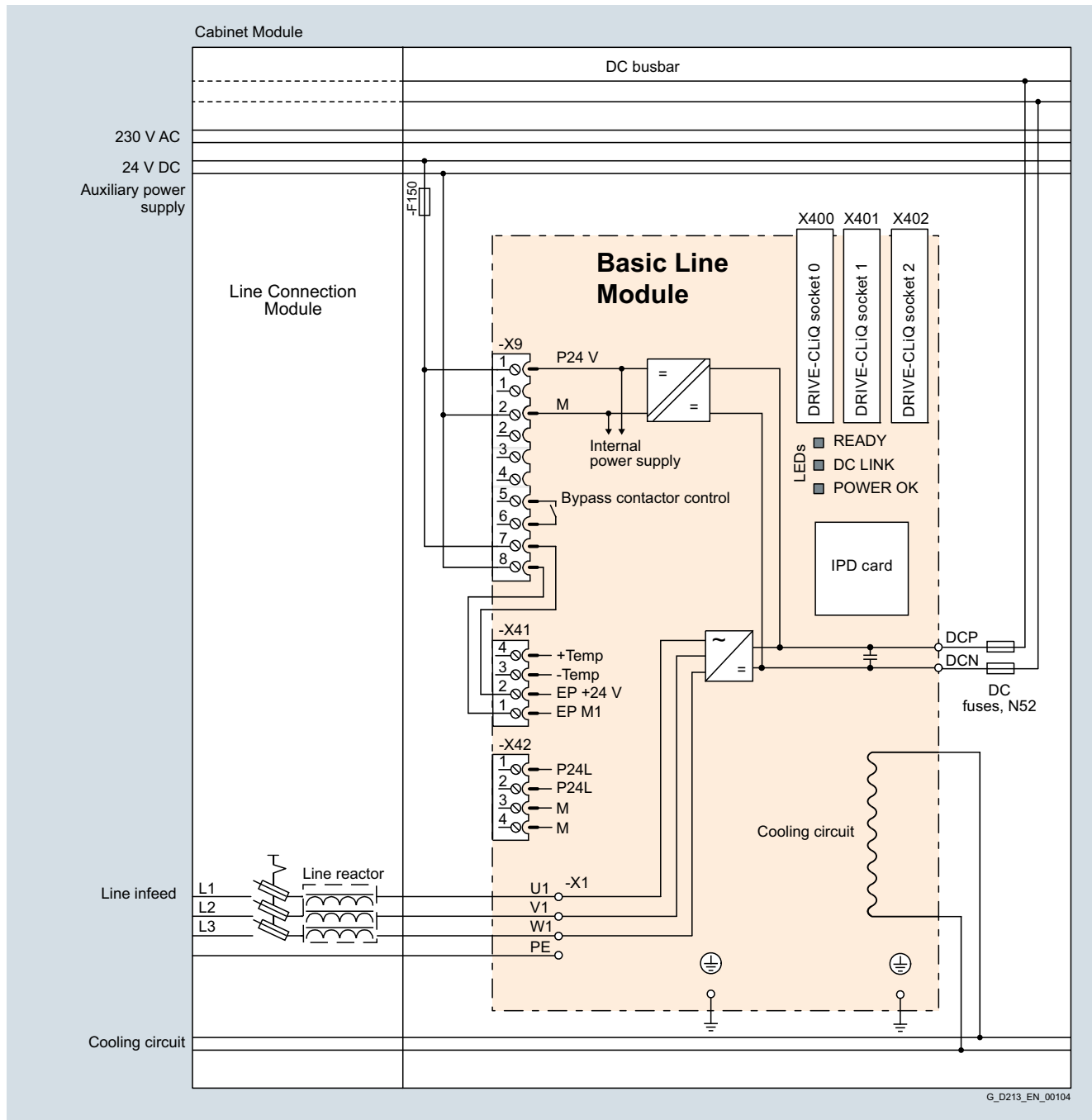

G_D213_EN_00104

Connection example of the Basic Line Connection Module, liquid-cooled

Technical specifications

Line voltage 380 ... 480 V 3 AC		Basic Line Connection Modules		
		6SL3735-1TE37-4LA3	6SL3735-1TE41-2LA3	6SL3735-1TE41-7LA3
Rated power				
• At $I_{rated\ DC}$ (50 Hz 400 V)	kW	360	600	830
• At $I_{H\ DC}$ (50 Hz 400 V)	kW	280	450	650
• At $I_{rated\ DC}$ (60 Hz 460 V)	hp	555	925	1280
• At $I_{H\ DC}$ (60 Hz 460 V)	hp	430	690	1000
DC link current				
• Rated current $I_{rated\ DC}$	A	740	1220	1730
• Base-load current $I_{H\ DC}^{1)}$	A	578	936	1350
• Maximum current $I_{max\ DC}$	A	1110	1830	2595
Input current				
• Rated current $I_{rated\ I}$	A	610	1000	1420
• Maximum current $I_{max\ I}$	A	915	1500	2130
Current demand				
• 24 V DC auxiliary power supply	A	0.7	0.7	0.7
• 230 V 1 AC	A	1.2	1.2	1.2
DC link capacitance				
• Basic Line Module	μF	12000	20300	26100
• Drive line-up, max.	μF	96000	162400	208800
Power loss, max. ²⁾ at 50 Hz 400 V				
• Degree of protection <IP55				
- Dissipated to coolant	kW	2.7	4.4	5.8
- Dissipated to ambient air	kW	2.7	3.5	4.2
• Degree of protection IP55				
- Dissipated to coolant	kW	4.9	7.4	9.5
- Dissipated to ambient air	kW	0.5	0.5	0.5
Coolant volume flow ³⁾		l/min	9/36	9/36
Degree of protection <IP55/IP55				12/39
Liquid volume		dm ³	6.6/10.2	6.6/10.2
Degree of protection <IP55/IP55				6.9/10.5
Pressure drop, max. ⁴⁾ for volume flow		Pa	150000	150000
Heat exchanger material			Aluminum	Aluminum
Sound pressure level L_{pA} (1 m) at 50/60 Hz		dB	54	56
Line supply connection L1, L2, L3			4/M12	5/M12 + 4/M16
• Conductor cross section, max. (IEC)	mm ²	4 × 240	8 × 240	10 × 240
PE/GND connection			PE bar	PE bar
• Busbar cross-section	mm ²	600	600	600
• Conductor cross section, max. (IEC)	mm ²	240	240	240
Cable length, max. ⁵⁾ Shielded/unshielded		m	2600/3900	4000/6000
Degree of protection (standard version)			IP21	IP21
Dimensions				
• Width	mm	1000	1000	1000
• Height	mm	2200	2200	2200
• Depth	mm	600	600	600
Weight, approx. (standard version)		kg	688	838
Frame size				
• Line Connection Module		HL	JL	JL
• Basic Line Module		FBL	FBL	GBL
Short-circuit current rating according to IEC		kA	65	84
Minimum short-circuit current ⁶⁾		A	8800	2000
				3200

¹⁾ The base-load current $I_{H\ DC}$ is the basis for a duty cycle of 150 % for 60 s or $I_{max\ DC}$ for 5 s with a duty cycle duration of 300 s.

²⁾ The specified power loss represents the maximum value at 100% utilization. The value is lower under normal operating conditions.

³⁾ The value applies to coolants comprising water and a mixture of water and anti-freeze agent.

⁴⁾ The value is valid for water as coolant. [Additional information and notes on other coolants is provided in the SINAMICS Low Voltage Engineering Manual.](#)

⁵⁾ Total of all motor cables and DC link. Longer cable lengths for specific configurations are available on request.

⁶⁾ Current required for reliably triggering protective devices.

SINAMICS S120 Cabinet Modules

Liquid-cooled units

Basic Line Connection Modules

Technical specifications (continued)

Line voltage 500 ... 690 V 3 AC		Basic Line Connection Modules			
		6SL3735-1TG34-2LA3	6SL3735-1TG37-3LA3	6SL3735-1TG41-3LA3	6SL3735-1TG41-7LA3
Rated power					
• At $I_{\text{rated DC}}$ (50 Hz 690 V)	kW	355	630	1100	1370
• At $I_{\text{H DC}}$ (50 Hz 690 V)	kW	275	475	840	1070
• At $I_{\text{rated DC}}$ (50 Hz 500 V)	kW	245	420	750	950
• At $I_{\text{H DC}}$ (50 Hz 500 V)	kW	200	345	610	775
• At $I_{\text{rated DC}}$ (60 Hz 575 V)	hp	395	705	1230	1530
• At $I_{\text{H DC}}$ (60 Hz 575 V)	hp	305	530	940	1195
DC link current					
• Rated current $I_{\text{rated DC}}$	A	420	730	1300	1650
• Base-load current $I_{\text{H DC}}^{1)}$	A	328	570	1014	1287
• Maximum current $I_{\text{max DC}}$	A	630	1095	1950	2475
Input current					
• Rated current $I_{\text{rated I}}$	A	340	600	1070	1350
• Maximum current $I_{\text{max I}}$	A	510	900	1605	2025
Current demand					
• 24 V DC auxiliary power supply	A	0.7	0.7	0.7	0.7
• 230 V 1 AC	A	1.2	1.2	1.2	1.2
DC link capacitance					
• Basic Line Module	μF	4800	7700	15500	19300
• Drive line-up, max.	μF	38400	61600	124000	154400
Power loss, max. ²⁾ at 50 Hz 690 V					
• Degree of protection <IP55					
- Dissipated to coolant	kW	1.8	2.7	4.7	5.7
- Dissipated to ambient air	kW	2.3	2.7	3.3	5.1
• Degree of protection IP55					
- Dissipated to coolant	kW	3.3	4.9	7.5	10.3
- Dissipated to ambient air	kW	0.5	0.5	0.5	0.5
Coolant volume flow ³⁾ Degree of protection <IP55/IP55		l/min	9/36	9/36	12/39
Liquid volume Degree of protection <IP55/IP55		dm ³	6.6/10.2	6.6/10.2	6.9/10.5
Pressure drop, max. ⁴⁾ for volume flow		Pa	150000	150000	150000
Heat exchanger material			Aluminum	Aluminum	Aluminum
Sound pressure level L_{pA} (1 m) at 50/60 Hz		dB	54	54	56
Line supply connection L1, L2, L3			2/M12	4/M12	5/M12 + 4/M16
• Conductor cross section, max. (IEC)	mm ²	2 × 150	4 × 240	8 × 240	8 × 240
PE/GND connection					
• Busbar cross-section	mm ²	PE bar 600	PE bar 600	PE bar 600	PE bar 600
• Conductor cross section, max. (IEC)	mm ²	240	240	240	240
Cable length, max. ⁵⁾ Shielded/unshielded		m	1500/2250	1500/2250	2250/3375
Degree of protection (standard version)			IP21	IP21	IP21
Dimensions					
• Width	mm	1000	1000	1000	1000
• Height	mm	2200	2200	2200	2200
• Depth	mm	600	600	600	600
Weight, approx. (standard version)		kg	578	668	995
Frame size					
• Line Connection Module		FL	GL	JL	JL
• Basic Line Module		FBL	FBL	GBL	GBL
Short-circuit current rating acc. to IEC		kA	65	84	100
Minimum short-circuit current ⁶⁾		A	4400	7200	2500

¹⁾ The base-load current $I_{\text{H DC}}$ is the basis for a duty cycle of 150 % for 60 s or $I_{\text{max DC}}$ for 5 s with a duty cycle duration of 300 s.

²⁾ The specified power loss represents the maximum value at 100% utilization. The value is lower under normal operating conditions.

³⁾ The value applies to coolants comprising water and a mixture of water and anti-freeze agent.

⁴⁾ The value is valid for water as coolant. [Additional information and notes on other coolants is provided in the SINAMICS Low Voltage Engineering Manual.](#)

⁵⁾ Total of all motor cables and DC link. Longer cable lengths for specific configurations are available on request.

⁶⁾ Current required for reliably triggering protective devices.

Overview



Active Line Connection Modules comprise a Line Connection Module, a liquid-cooled Active Interface Module and a liquid-cooled Active Line Module. They can supply motoring energy to the DC link and return regenerative energy to the line supply.

As standard, the Active Line Connection Module is positioned in the drive lineup so that the Motor Modules are arranged to the right. If Motor Modules are to be arranged to the left of the Active Line Connection Module, option **M88** (DC bus system for line-side Cabinet Modules) must be ordered.

Line Connection Modules contain the line-side infeed via main breaker with fuse switch disconnecter or circuit breaker and establish the connection between the plant power system and the Active Line Modules. It is equipped as standard with a radio interference suppression filter according to EN 61800-3 Category C3.

Active Line Connection Modules produce a stabilized DC voltage that remains constant regardless of fluctuations in the line voltage (the line voltage must remain within the permissible tolerances).

In the factory setting, the DC voltage is regulated to 1.5 times the rms value of the rated line voltage.

Active Line Connection Modules draw a virtually sinusoidal current from the supply system and cause virtually no line harmonics.

Active Line Connection Modules are suitable for connection to supply systems grounded at the neutral point (TN, TT) and non-grounded (IT) supply systems. The following voltages and currents are available:

Line voltage	Rated infeed/regenerative feedback current	Rated power
380 ... 480 V 3 AC	985 ... 1405 A	630 ... 900 kW
500 ... 690 V 3 AC	1025 ... 1560 A	1100 ... 1700 kW

Design

Active Line Modules always include an Active Interface Module, which contains the associated Clean Power Filter and pre-charging circuit. The line filter that is included ensures compliance with the EMC requirements for the "second environment".

Depending on the input current, the following versions are available:

- ≤ 800 A: Main circuit breaker with fuse switch disconnecter
- > 800 A: Circuit breaker, type 3WL, with option **L25** as withdrawable circuit breaker

The power rating can be increased by connecting Active Line Connection Modules in parallel. You must observe the following rules:

- Up to four identical Active Line Connection Modules can be connected in parallel.
- A common Control Unit is required whenever the modules are connected in parallel.
- The parallel connection must be supplied from a common infeed point (i.e. the modules cannot be operated on different line supplies).
- A derating factor of 5% must be taken into consideration, regardless of the number of modules connected in parallel.
- The main contactors or circuit breakers of the respective Line Connection Modules must close together and simultaneously. Monitoring is performed via the -X50 terminals of the respective Line Connection Module.
- Option **M88** must be ordered.

For additional information, please refer to the [SINAMICS Low Voltage Engineering Manual](#).

Selection and ordering data

Rated power at 400 V or 690 V kW	Rated DC link current A	Active Line Connection Module Article No.
Line voltage 380 ... 480 V 3 AC (DC link voltage 540 ... 720 V DC)		
630	1100	6SL3735-7TE41-0LA3
900	1573	6SL3735-7TE41-4LA3
Line voltage 500 ... 690 V 3 AC (DC link voltage 710 ... 1035 V DC)		
1100	1147	6SL3735-7TG41-0LA3
1400	1422	6SL3735-7TG41-3LA3
1700	1740	6SL3735-7TG41-6LA3

SINAMICS S120 Cabinet Modules

Liquid-cooled units

Active Line Connection Modules

Integration

4

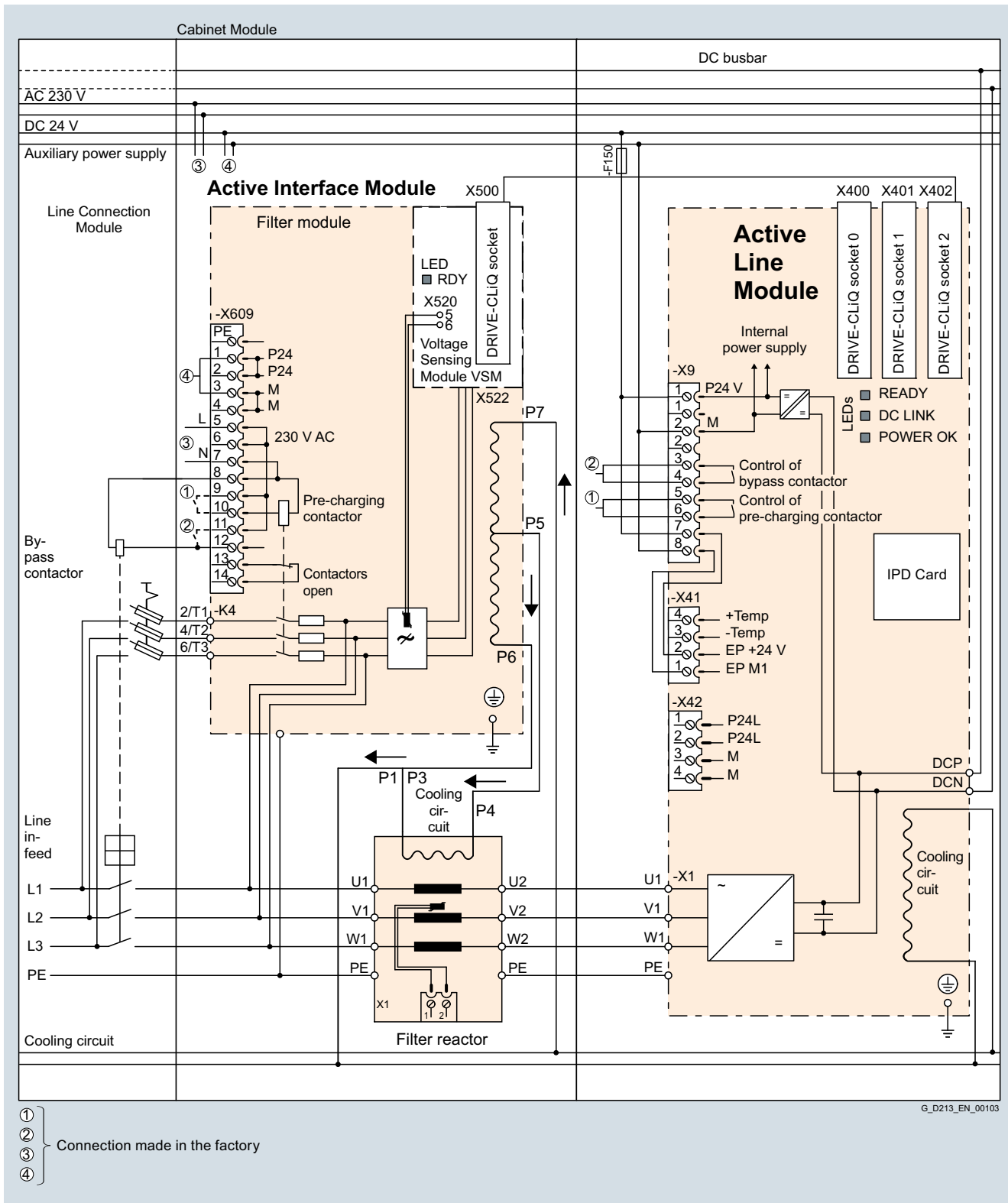

Connection example for the Active Line Connection Module, liquid-cooled

Technical specifications

Line voltage 380 ... 480 V 3 AC		Active Line Connection Modules	
		6SL3735-7TE41-0LA3	6SL3735-7TE41-4LA3
Rated power			
• At $I_{\text{rated DC}}$ (50 Hz 400 V)	kW	630	900
• At $I_{\text{H DC}}$ (50 Hz 400 V)	kW	545	780
• At $I_{\text{rated DC}}$ (60 Hz 460 V)	hp	900	1250
• At $I_{\text{H DC}}$ (60 Hz 460 V)	hp	800	1000
DC link current			
• Rated current $I_{\text{rated DC}}$	A	1100	1573
• Base-load current $I_{\text{H DC}}^{1)}$	A	982	1401
• Maximum current $I_{\text{max DC}}$	A	1654	2361
Infeed/regenerative feedback current			
• Rated current $I_{\text{rated I}}$	A	985	1405
• Maximum current $I_{\text{max I}}$	A	1477	2055
Current demand			
• 24 V DC auxiliary power supply	A	1.77	1.77
• 230 V 1 AC	A	1.2	1.2
DC link capacitance			
• Active Line Module	μF	18900	28800
• Drive line-up, max.	μF	230400	230400
Power loss, max. 2) at 50 Hz 400 V			
• Degree of protection <IP55			
- Dissipated to coolant	kW	19.6	21.8
- Dissipated to ambient air	kW	3.1	3.8
• Degree of protection IP55			
- Dissipated to coolant	kW	21.8	24.7
- Dissipated to ambient air	kW	0.9	0.9
Coolant volume flow 3)			
Degree of protection <IP55/IP55	l/min	43/70	43/70
Liquid volume			
Degree of protection <IP55/IP55	dm^3	14/17.6	14/17.6
Pressure drop, max. 4) for volume flow			
	Pa	150000	150000
Heat exchanger material			
• Active Line Module		Aluminum	Aluminum
• Active Interface Module		Aluminum	Aluminum
Sound pressure level $L_{\text{pA}}^{5)}$ (1 m) at 50/60 Hz			
	dB	71/71	71/71
Line supply connection			
L1, L2, L3		5/M12 + 4/M16	5/M12 + 4/M16
• Conductor cross section, max. (IEC)	mm^2	8 × 240	10 × 240
PE/GND connection			
• Busbar cross-section	mm^2	PE bar 600	PE bar 600
• Conductor cross section, max. (IEC)	mm^2	240	240
Cable length, max. 6)			
Shielded/unshielded	m	3900/5850	3900/5850
Degree of protection (standard version)			
		IP21	IP21
Dimensions			
• Width	mm	1600	1600
• Height	mm	2200	2200
• Depth	mm	600	600
Weight, approx. (standard version)			
	kg	1430	1470
Frame size			
• Line Connection Module		JL	JL
• Active Interface Module		JIL	JIL
• Active Line Module		JXL	JXL
Short-circuit current rating acc. to IEC			
	kA	84	100
Minimum short-circuit current 7)			
	A	2000	3200

1) The base-load current $I_{\text{H DC}}$ is the basis for a duty cycle of 150 % for 60 s or $I_{\text{max DC}}$ for 5 s with a duty cycle duration of 300 s.

2) The specified power loss represents the maximum value at 100% utilization. The value is lower under normal operating conditions.

3) The value applies to coolants comprising water and a mixture of water and anti-freeze agent.

4) The value is valid for water as coolant. [Additional information and notes on other coolants is provided in the SINAMICS Low Voltage Engineering Manual.](#)

5) Total sound pressure level of Active Interface Module and Active Line Module.

6) Total of all motor cables and DC link. Longer cable lengths for specific configurations are available on request.

7) Current required for reliably triggering protective devices.

SINAMICS S120 Cabinet Modules

Liquid-cooled units

Active Line Connection Modules

Technical specifications (continued)

Line voltage 500 ... 690 V 3 AC		Active Line Connection Modules		
		6SL3735-7TG41-0LA3	6SL3735-7TG41-3LA3	6SL3735-7TG41-6LA3
Rated power				
• At $I_{\text{rated DC}}$ (50 Hz 690 V)	kW	1100	1400	1700
• At $I_{\text{H DC}}$ (50 Hz 690 V)	kW	1000	1215	1490
• At $I_{\text{rated DC}}$ (50 Hz 500 V)	kW	780	965	1180
• At $I_{\text{H DC}}$ (50 Hz 500 V)	kW	710	880	1080
• At $I_{\text{rated DC}}$ (60 Hz 575 V)	hp	1250	1500	1855
• At $I_{\text{H DC}}$ (60 Hz 575 V)	hp	1000	1250	1530
DC link current				
• Rated current $I_{\text{rated DC}}$	A	1147	1422	1740
• Base-load current $I_{\text{H DC}}^{1)}$	A	1022	1266	1550
• Maximum current $I_{\text{max DC}}$	A	1722	2133	2620
Infeed/regenerative feedback current				
• Rated current $I_{\text{rated I}}$	A	1025	1270	1560
• Maximum current $I_{\text{max I}}$	A	1537	1905	2055
Current demand				
• 24 V DC auxiliary power supply	A	1.77	1.63	1.67
• 230 V 1 AC	A	1.2	1.2	1.2
DC link capacitance				
• Active Line Module	μF	19330	19330	21000
• Drive line-up, max.	μF	153600	153600	210000
Power loss, max. ²⁾ at 50 Hz 690 V				
• Degree of protection <IP55				
- Dissipated to coolant	kW	21.6	27.3	37.7
- Dissipated to ambient air	kW	3.1	3.7	4.4
• Degree of protection IP55				
- Dissipated to coolant	kW	23.7	30.1	39.2
- Dissipated to ambient air	kW	0.9	0.9	0.9
Coolant volume flow ³⁾				
Degree of protection <IP55/IP55	l/min	43/70	43/70	43/70
Liquid volume				
Degree of protection <IP55/IP55	dm ³	14/17.6	14/17.6	14/17.6
Pressure drop, max. ⁴⁾ for volume flow				
	Pa	150000	150000	150000
Heat exchanger material				
• Active Line Module		Aluminum	Aluminum	Aluminum
• Active Interface Module		Aluminum	Aluminum	Aluminum
Sound pressure level L_{pA} ⁵⁾ (1 m) at 50/60 Hz				
	dB	71/71	71/71	71/71
Line supply connection				
L1, L2, L3		5/M12 + 4/M16	5/M12 + 4/M16	5/M12 + 4/M16
• Conductor cross section, max. (IEC)	mm ²	8 × 240	8 × 240	8 × 240
PE/GND connection				
• Busbar cross-section	mm ²	PE bar 600	PE bar 600	PE bar 600
• Conductor cross section, max. (IEC)	mm ²	240	240	240
Cable length, max. ⁶⁾				
Shielded/unshielded	m	2250/3375	2250/3375	2250/3375
Degree of protection (standard version)				
		IP21	IP21	IP21
Dimensions				
• Width	mm	1600	1600	1600
• Height	mm	2200	2200	2200
• Depth	mm	600	600	600
Weight, approx. (standard version)				
	kg	1520	1540	1640
Frame size				
• Line Connection Module		JL	JL	JL
• Active Interface Module		JIL	JIL	JIL
• Active Line Module		JXL	JXL	JXL
Short-circuit current rating acc. to IEC				
	kA	100	100	100
Minimum short-circuit current ⁷⁾				
	A	2000	3200	3200

¹⁾ The base-load current $I_{\text{H DC}}$ is the basis for a duty cycle of 150 % for 60 s or $I_{\text{max DC}}$ for 5 s with a duty cycle duration of 300 s.

²⁾ The specified power loss represents the maximum value at 100% utilization. The value is lower under normal operating conditions.

³⁾ The value applies to coolants comprising water and a mixture of water and anti-freeze agent.

⁴⁾ The value is valid for water as coolant. [Additional information and notes on other coolants is provided in the SINAMICS Low Voltage Engineering Manual.](#)

⁵⁾ Total sound pressure level of Active Interface Module and Active Line Module.

⁶⁾ Total of all motor cables and DC link. Longer cable lengths for specific configurations are available on request.

⁷⁾ Current required for reliably triggering protective devices.

Overview



Motor Modules are available in the power range from 90 kW to 1500 kW.

Line voltage	DC link voltage	Type rating
380 ... 480 V 3 AC	510 ... 720 V DC	315 ... 800 kW
500 ... 690 V 3 AC	675 ... 1035 V DC	450 ... 1500 kW

By connecting in parallel up to four Motor Modules, which are operated on one Control Unit and supply one motor, it is possible to increase the available shaft power to max. approx. 5700 kW (taking into account the derating factors according to the SINAMICS Low Voltage Engineering Manual).

The Motor Modules can also be used as Braking Modules (braking chopper) if a 3-phase braking resistor is connected instead of a motor.

For more detailed information on this topic, please refer to the SINAMICS Low Voltage Engineering Manual.

Design

Motor Modules contain the following components as standard:

- Retaining device for the DC busbar, including the connection to the DC connections of the Motor Module
- Connection busbars, nickel-plated
 - on Motor Modules, frame size JXL, the connection for the motor cables is routed to the right of the device
 - on Motor Modules, frame size HXL, the connection is underneath the device
- Cable retaining bar for the power cables
- DRIVE-CLiQ interface (three DRIVE-CLiQ sockets), without Control Unit
- Auxiliary power supply system (4-pole) for the auxiliary power supply, including cable connections for looping through to the next Cabinet Module
- Nickel-plated PE busbar (60 x 10 mm), including jumper for looping through to the next Cabinet Module
- EMC-compliant design thanks to additional shielding measures and appropriately routed cables

Selection and ordering data

Type rating at 400 V or 690 V kW	Rated output current I_{rated} A	Motor Module Article No.
Line voltage 380 ... 480 V 3 AC (DC link voltage 510 ... 720 V DC)		
315	605	6SL3725-1TE36-1AA3
400	745	6SL3725-1TE37-5AA3
450	840	6SL3725-1TE38-4AA3
560	985	6SL3725-1TE41-0AA3
710	1260	6SL3725-1TE41-2AA3
800	1405	6SL3725-1TE41-4AA3
800	1330	6SL3725-1TE41-4AS3
Line voltage 500 ... 690 V 3 AC (DC link voltage 675 ... 1035 V DC)		
450	465	6SL3725-1TG34-7AA3
560	575	6SL3725-1TG35-8AA3
710	735	6SL3725-1TG37-4AA3
800	810	6SL3725-1TG38-0AA3
800	810	6SL3725-1TG38-1AA3
1000	1025	6SL3725-1TG41-0AA3
1200	1270	6SL3725-1TG41-3AA3
1500	1560	6SL3725-1TG41-6AA3

SINAMICS S120 Cabinet Modules

Liquid-cooled units

Motor Modules

Integration

Motor Modules are controlled by the CU320-2 DP or CU320-2 PN Control Unit. Communication between the Control Unit and Modules is established via a DRIVE-CLiQ connection.

If the Control Unit is integrated in the same cabinet as an option with order code **K90** or **K95**, these communication cables will al-

ready be installed. If the Control Unit is to be mounted externally, the DRIVE-CLiQ cable will not be included in the scope of delivery and must be configured on site.

For additional information, please refer to the [SINAMICS Low Voltage Engineering Manual](#).

4

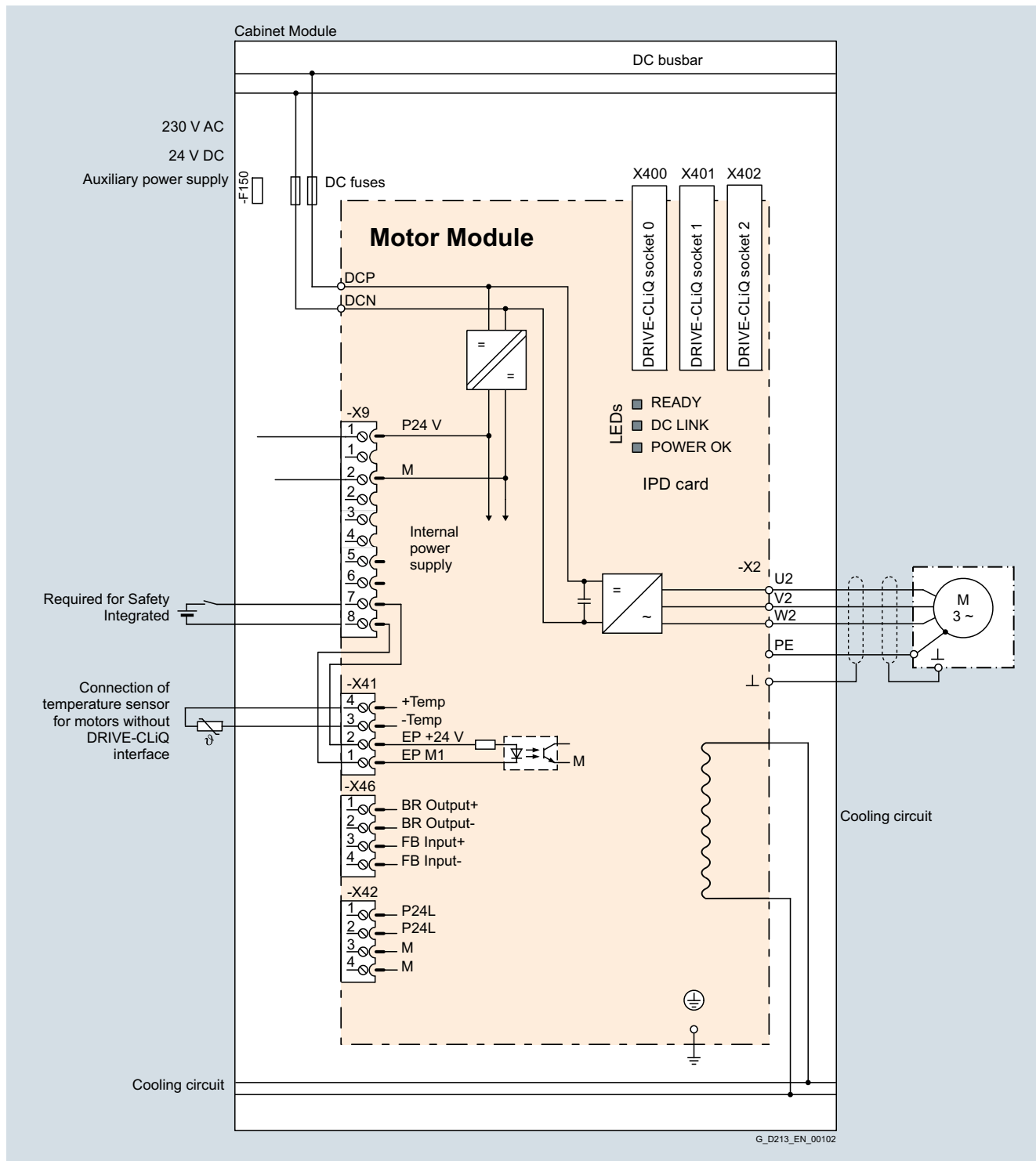

G_D213_EN_00102

Connection example of a Motor Module, liquid-cooled

Technical specifications

Line voltage 380 ... 480 V 3 AC		Motor Modules		
DC link voltage 510 ... 720 V DC		6SL3725-1TE36-1AA3	6SL3725-1TE37-5AA3	6SL3725-1TE38-4AA3
Type rating				
• At I_L (50 Hz 400 V) ¹⁾	kW	315	400	450
• At I_H (50 Hz 400 V) ¹⁾	kW	250	315	400
• At I_L (60 Hz 460 V) ²⁾	hp	500	600	700
• At I_H (60 Hz 460 V) ²⁾	hp	350	450	600
Output current				
• Rated current $I_{rated O}$	A	605	745	840
• Base-load current $I_L^{(3)}$	A	590	725	820
• Base-load current $I_H^{(4)}$	A	460	570	700
• Maximum current $I_{max O}$	A	885	1087	1230
DC link current				
• Rated current $I_{rated DC}$ when suppl. via				
- Basic Line Module	A	738	894	1025
- Active Line Module	A	664	805	922
• Base-load current $I_{L DC}^{(3)}$ when suppl. via				
- Basic Line Module	A	719	871	1000
- Active Line Module	A	646	784	898
• Base-load current $I_{H DC}^{(4)}$ when suppl. via				
- Basic Line Module	A	561	795	853
- Active Line Module	A	504	716	767
Current demand				
• 24 V DC auxiliary power supply	A	1.6	1.6	1.6
• 230 V 1 AC	A	0.6	0.6	0.6
DC link capacitance				
	μF	12600	17400	17400
Pulse frequency ⁵⁾				
• Rated frequency	kHz	1.25	1.25	1.25
• Pulse frequency, max.				
- Without current derating	kHz	1.25	1.25	1.25
- With current derating	kHz	7.5	7.5	7.5
Power loss, max. ⁶⁾ at 50 Hz 400 V				
• Degree of protection <IP55				
- Dissipated to coolant	kW	4.6	5.2	5.5
- Dissipated to ambient air	kW	0.6	0.7	0.8
• Degree of protection IP55				
- Dissipated to coolant	kW	5.0	5.7	6.2
- Dissipated to ambient air	kW	0.2	0.2	0.2
Coolant volume flow ⁷⁾				
All degrees of protection	l/min	16	16	16
Liquid volume				
Degree of protection <IP55/IP55	dm ³	3.3/5.1	3.3/5.1	3.3/5.1
Pressure drop, max. ⁸⁾ for volume flow				
	Pa	150000	150000	150000
Heat exchanger material				
		Aluminum	Aluminum	Aluminum
Sound pressure level L_{pA} (1 m) at 50/60 Hz				
	dB	54	54	54
Motor connection U2, V2, W2				
• Conductor cross section, max. (IEC)	mm ²	2/M12 4 × 185	2/M12 4 × 185	2/M12 4 × 185
PE/GND connection				
• Busbar cross-section	mm ²	600	600	600
• Conductor cross section, max. (IEC)	mm ²	240	240	240
Cable length, max. ⁹⁾ Shielded/unshield.				
		300/450	300/450	300/450
Degree of protection (standard version)				
		IP21	IP21	IP21
Dimensions				
• Width	mm	400	400	400
• Height	mm	2200	2200	2200
• Depth	mm	600	600	600
Weight, approx.				
	kg	350	350	350
Frame size				
		HXL	HXL	HXL
Short-circuit current rating acc. to IEC				
	kA	65	65	84

¹⁾ Rated output of a typical 6-pole standard induction motor based on I_L or I_H for 400 V 3 AC 50 Hz.

²⁾ Rated output of a typical 6-pole standard induction motor based on I_L or I_H for 460 V 3 AC 60 Hz.

³⁾ The base-load current I_L is based on a load cycle of 110 % for 60 s or 150 % for 10 s with a load cycle duration of 300 s.

⁴⁾ The base-load current I_H is based on a duty cycle of 150 % for 60 s or 160 % for 10 s with a duty cycle duration of 300 s.

⁵⁾ Information regarding the correlation between the pulse frequency and max. output current/output frequency is provided in the SINAMICS Low Voltage Engineering Manual.

⁶⁾ The specified power loss represents the maximum value at 100% utilization. The value is lower under normal operating conditions.

⁷⁾ The value applies to coolants comprising water and a mixture of water and anti-freeze agent.

⁸⁾ The value is valid for water as coolant. [Additional information and notes on other coolants is provided in the SINAMICS Low Voltage Engineering Manual.](#)

⁹⁾ Total of all motor cables. Longer cable lengths for specific configurations are available on request. [For additional information, please refer to the SINAMICS Low Voltage Engineering Manual.](#)

SINAMICS S120 Cabinet Modules

Liquid-cooled units

Motor Modules

Technical specifications (continued)

Line voltage 380 ... 480 V 3 AC		Motor Modules			
DC link voltage 510 ... 720 V DC		6SL3725-1TE41-0AA3	6SL3725-1TE41-2AA3	6SL3725-1TE41-4AA3	6SL3725-1TE41-4AS3 ¹⁰⁾
Type rating					
• At I_L (50 Hz 400 V) ¹⁾	kW	560	710	800	800
• At I_H (50 Hz 400 V) ¹⁾	kW	450	630	710	630
• At I_L (60 Hz 460 V) ²⁾	hp	800	1000	1150	1000
• At I_H (60 Hz 460 V) ²⁾	hp	700	900	1000	900
Output current					
• Rated current $I_{rated O}$	A	985	1260	1405	1330
• Base-load current $I_L^{(3)}$	A	960	1230	1370	1310
• Base-load current $I_H^{(4)}$	A	860	1127	1257	1150
• Maximum current $I_{max O}$	A	1440	1845	2055	2055
DC link current					
• Rated current $I_{rated DC}$ when suppl. via					
- Basic Line Module	A	1202	1512	1714	1550
- Active Line Module	A	1080	1361	1544	1403
• Base-load current $I_{DC}^{(3)}$ when suppl. via					
- Basic Line Module	A	1170	1474	1670	1525
- Active Line Module	A	1051	1326	1500	1405
• Base-load current $I_{HDC}^{(4)}$ when suppl. via					
- Basic Line Module	A	1048	1345	1532	1676
- Active Line Module	A	942	1211	1377	1403
Current demand					
• 24 V DC auxiliary power supply	A	1.46	1.46	1.46	1.46
• 230 V 1 AC	A	0.6	0.6	0.6	0.6
DC link capacitance					
	μF	21000	29000	29000	21000
Pulse frequency ⁵⁾					
• Rated frequency	kHz	1.25	1.25	1.25	2
• Pulse frequency, max.					
- Without current derating	kHz	1.25	1.25	1.25	2
- With current derating	kHz	7.5	7.5	7.5	4
Power loss, max. ⁶⁾ at 50 Hz 400 V					
• Degree of protection <IP55					
- Dissipated to coolant	kW	7.5	8.6	9.5	10.2
- Dissipated to ambient air	kW	1.0	1.3	1.5	1.4
• Degree of protection IP55					
- Dissipated to coolant	kW	8.3	9.6	10.7	11.3
- Dissipated to ambient air	kW	0.2	0.3	0.3	0.3
Coolant volume flow ⁷⁾					
All degrees of protection	l/min	27	27	27	27
Liquid volume					
Degree of protection <IP55/IP55	dm ³	5.2/7	5.2/7	5.2/7	5.2/7
Pressure drop, max. ⁸⁾ for volume flow					
	Pa	150000	150000	150000	150000
Heat exchanger material					
		Aluminum	Aluminum	Aluminum	Aluminum
Sound pressure level L_{pA} (1 m) at 50/60 Hz					
	dB	56	56	56	56
Motor connection U2, V2, W2					
		2/M12	2/M12	2/M12	2/M12
• Conductor cross section, max. (IEC)	mm ²	4 × 240	4 × 240	4 × 240	4 × 240
PE/GND connection					
• Busbar cross-section	mm ²	600	600	600	600
• Conductor cross section, max. (IEC)	mm ²	240	240	240	240
Cable length, max. ⁹⁾ Shielded/unshield.					
	m	300/450	300/450	300/450	300/450
Degree of protection (standard version)					
		IP21	IP21	IP21	IP21
Dimensions					
• Width	mm	600	600	600	600
• Height	mm	2200	2200	2200	2200
• Depth	mm	600	600	600	600
Weight, approx.					
	kg	460	460	460	470
Frame size					
		JXL	JXL	JXL	JXL
Short-circuit current rating acc. to IEC					
	kA	84	100	100	100

¹⁾ Rated output of a typical 6-pole standard induction motor based on I_L or I_H for 400 V 3 AC 50 Hz.

²⁾ Rated output of a typical 6-pole standard induction motor based on I_L or I_H for 460 V 3 AC 60 Hz.

³⁾ The base-load current I_L is based on a load cycle of 110 % for 60 s or 150 % for 10 s with a load cycle duration of 300 s.

⁴⁾ The base-load current I_H is based on a duty cycle of 150 % for 60 s or 160 % for 10 s with a duty cycle duration of 300 s.

⁵⁾ Information regarding the correlation between the pulse frequency and max. output current/output frequency is provided in the SINAMICS Low Voltage Engineering Manual.

⁶⁾ The specified power loss represents the maximum value at 100% utilization. The value is lower under normal operating conditions.

⁷⁾ The value applies to coolants comprising water and a mixture of water and anti-freeze agent.

⁸⁾ The value is valid for water as coolant. [Additional information and notes on other coolants is provided in the SINAMICS Low Voltage Engineering Manual.](#)

⁹⁾ Total of all motor cables. Longer cable lengths for specific configurations are available on request. [For additional information, please refer to the SINAMICS Low Voltage Engineering Manual.](#)

¹⁰⁾ This Motor Module has been specifically designed for loads demanding a high dynamic performance. The derating factor k_{IGBT} and the derating characteristics can be ignored (see section "Duty cycles" in the SINAMICS Low Voltage Engineering Manual).

Technical specifications (continued)

Line voltage 500 ... 690 V 3 AC		Motor Modules			
DC link voltage 675 ... 1035 V DC		6SL3725-1TG34-7AA3	6SL3725-1TG35-8AA3	6SL3725-1TG37-4AA3	6SL3725-1TG38-0AA3 ¹⁰⁾
Type rating					
• At I_L (50 Hz 690 V) ¹⁾	kW	450	560	710	800
• At I_H (50 Hz 690 V) ¹⁾	kW	400	450	630	710
• At I_L (50 Hz 500 V) ¹⁾	kW	315	400	500	560
• At I_H (50 Hz 500 V) ¹⁾	kW	250	315	450	500
• At I_L (60 Hz 575 V) ²⁾	hp	450	600	700	800
• At I_H (60 Hz 575 V) ²⁾	hp	450	500	700	700
Output current					
• Rated current $I_{rated O}$	A	465	575	735	810
• Base-load current $I_L^{(3)}$	A	452	560	710	790
• Base-load current $I_H^{(4)}$	A	416	514	657	724
• Maximum current $I_{max O}$	A	678	840	1065	1185
DC link current					
• Rated current $I_{rated DC}$ when suppl. via					
- Basic Line Module	A	558	702	903	990
- Active Line Module	A	502	632	759	891
• Base-load current $I_{L DC}^{(3)}$ when suppl. via					
- Basic Line Module	A	544	683	870	948
- Active Line Module	A	489	616	781	870
• Base-load current $I_{H DC}^{(4)}$ when suppl. via					
- Basic Line Module	A	496	627	795	885
- Active Line Module	A	446	565	732	808
Current demand					
• 24 V DC auxiliary power supply	A	1.6	1.6	1.6	1.6
• 230 V 1 AC	A	0.6	0.6	0.6	0.6
DC link capacitance					
	μF	9670	9670	10500	10500
Pulse frequency ⁵⁾					
• Rated frequency	kHz	1.25	1.25	1.25	1.25
• Pulse frequency, max.					
- Without current derating	kHz	1.25	1.25	1.25	1.25
- With current derating	kHz	7.5	7.5	7.5	7.5
Power loss, max. ⁶⁾ at 50 Hz 690 V					
• Degree of protection <IP55					
- Dissipated to coolant	kW	5.3	5.5	7.5	8.3
- Dissipated to ambient air	kW	0.4	0.5	0.6	0.7
• Degree of protection IP55					
- Dissipated to coolant	kW	5.6	5.8	7.9	8.8
- Dissipated to ambient air	kW	0.2	0.2	0.2	0.2
Coolant volume flow ⁷⁾					
All degrees of protection	l/min	16	16	16	16
Liquid volume					
Degree of protection <IP55/IP55	dm ³	3.3/5.1	3.3/5.1	3.3/5.1	3.3/5.1
Pressure drop, max. ⁸⁾ for volume flow					
	Pa	150000	150000	150000	150000
Heat exchanger material					
		Aluminum	Aluminum	Aluminum	Aluminum
Sound pressure level L_{pA} (1 m) at 50/60 Hz					
	dB	54	54	54	54
Motor connection U2, V2, W2					
• Conductor cross section, max. (IEC)	mm ²	2/M12 4 × 185	2/M12 4 × 185	2/M12 4 × 185	2/M12 4 × 185
PE/GND connection					
• Busbar cross-section	mm ²	PE bar 600	PE bar 600	PE bar 600	PE bar 600
• Conductor cross section, max. (IEC)	mm ²	240	240	240	240
Cable length, max. ⁹⁾ Shielded/unshield.					
	m	300/450	300/450	300/450	300/450
Degree of protection (standard version)					
		IP21	IP21	IP21	IP21
Dimensions					
• Width	mm	400	400	400	400
• Height	mm	2200	2200	2200	2200
• Depth	mm	600	600	600	600
Weight, approx.					
	kg	350	350	350	350
Frame size					
		HXL	HXL	HXL	HXL
Short-circuit current rating acc. to IEC					
	kA	84	84	100	100

¹⁾ Rated output of a typical 6-pole standard induction motor based on I_L or I_H for 500 V or 690 V 3 AC 50 Hz.
²⁾ Rated output of a typical 6-pole standard induction motor based on I_L or I_H for 575 V 3 AC 60 Hz.
³⁾ The base-load current I_L is based on a load cycle of 110 % for 60 s or 150 % for 10 s with a load cycle duration of 300 s.
⁴⁾ The base-load current I_H is based on a duty cycle of 150 % for 60 s or 160 % for 10 s with a duty cycle duration of 300 s.
⁵⁾ Information regarding the correlation between the pulse frequency and max. output current/output frequency is provided in the SINAMICS Low Voltage Engineering Manual.

⁶⁾ The specified power loss represents the maximum value at 100% utilization. The value is lower under normal operating conditions.
⁷⁾ The value applies to coolants comprising water and a mixture of water and anti-freeze agent.
⁸⁾ The value is valid for water as coolant. [Additional information and notes on other coolants is provided in the SINAMICS Low Voltage Engineering Manual.](#)
⁹⁾ Total of all motor cables. Longer cable lengths for specific configurations are available on request. [For additional information, please refer to the SINAMICS Low Voltage Engineering Manual.](#)
¹⁰⁾ The device is optimized for a base pulse frequency of 1.25 kHz, for an increased pulse frequency – or for certain overloads the derating factor is higher than that for the device with article number 6SL3325-1TG38-1AAx.

SINAMICS S120 Cabinet Modules

Liquid-cooled units

Motor Modules

Technical specifications (continued)

Line voltage 500 ... 690 V 3 AC		Motor Modules			
DC link voltage 675 ... 1035 V DC		6SL3725-1TG38-1AA3	6SL3725-1TG41-0AA3	6SL3725-1TG41-3AA3	6SL3725-1TG41-6AA3
Type rating					
• At I_L (50 Hz 690 V) ¹⁾	kW	800	1000	1200	1500
• At I_H (50 Hz 690 V) ¹⁾	kW	710	900	1000	1260
• At I_L (50 Hz 500 V) ¹⁾	kW	560	710	900	1000
• At I_H (50 Hz 500 V) ¹⁾	kW	560	630	800	900
• At I_L (60 Hz 575 V) ²⁾	hp	800	1000	1250	1500
• At I_H (60 Hz 575 V) ²⁾	hp	700	900	1000	1250
Output current					
• Rated current $I_{rated O}$	A	810	1025	1270	1560
• Base-load current I_L ³⁾	A	790	1000	1230	1500
• Base-load current I_H ⁴⁾	A	724	917	1136	1284
• Maximum current $I_{max O}$	A	1185	1500	1845	2055
DC link current					
• Rated current $I_{rated DC}$ when suppl. via					
- Basic Line Module	A	990	1250	1550	1903
- Active Line Module	A	891	1125	1395	1605
• Base-load current $I_{L DC}$ ³⁾ when suppl. via					
- Basic Line Module	A	963	1219	1500	1800
- Active Line Module	A	869	1100	1353	1650
• Base-load current $I_{H DC}$ ⁴⁾ when suppl. via					
- Basic Line Module	A	883	1118	1384	1680
- Active Line Module	A	796	1009	1250	1550
Current demand					
• 24 V DC auxiliary power supply	A	1.46	1.46	1.46	1.46
• 230 V 1 AC	A	0.6	0.6	0.6	0.6
DC link capacitance					
	μF	14000	16000	19330	21000
Pulse frequency ⁵⁾					
• Rated frequency	kHz	1.25	1.25	1.25	1.25
• Pulse frequency, max.					
- Without current derating	kHz	1.25	1.25	1.25	1.25
- With current derating	kHz	7.5	7.5	7.5	7.5
Power loss, max. ⁶⁾ at 50 Hz 690 V					
• Degree of protection <IP55					
- Dissipated to coolant	kW	9.0	10.0	12.9	17.1
- Dissipated to ambient air	kW	1.1	1.2	1.4	1.6
• Degree of protection IP55					
- Dissipated to coolant	kW	9.8	11.2	14.0	18.4
- Dissipated to ambient air	kW	0.3	0.3	0.3	0.3
Coolant volume flow ⁷⁾					
All degrees of protection	l/min	27	27	27	27
Liquid volume					
Degree of protection <IP55/IP55	dm ³	5.2/7	5.2/7	5.2/7	5.2/7
Pressure drop, max. ⁸⁾ for volume flow					
	Pa	150000	150000	150000	150000
Heat exchanger material					
		Aluminum	Aluminum	Aluminum	Aluminum
Sound pressure level L_{pA} (1 m) at 50/60 Hz					
	dB	56	56	56	56
Motor connection U2, V2, W2					
• Conductor cross section, max. (IEC)	mm ²	4 × 240	4 × 240	4 × 240	4 × 240
PE/GND connection					
• Busbar cross-section	mm ²	600	600	600	600
• Conductor cross section, max. (IEC)	mm ²	240	240	240	240
Cable length, max. ⁹⁾ Shielded/unshield.					
	m	300/450	300/450	300/450	300/450
Degree of protection (standard version)					
		IP21	IP21	IP21	IP21
Dimensions					
• Width	mm	600	600	600	600
• Height	mm	2200	2200	2200	2200
• Depth	mm	600	600	600	600
Weight, approx.					
	kg	460	460	460	470
Frame size					
		JXL	JXL	JXL	JXL
Short-circuit current rating acc. to IEC					
	kA	100	100	100	100

¹⁾ Rated output of a typical 6-pole standard induction motor based on I_L or I_H for 500 V or 690 V 3 AC 50 Hz

²⁾ Rated output of a typical 6-pole standard induction motor based on I_L or I_H for 575 V 3 AC 60 Hz.

³⁾ The base-load current I_L is based on a load cycle of 110 % for 60 s or 150 % for 10 s with a load cycle duration of 300 s.

⁴⁾ The base-load current I_H is based on a duty cycle of 150 % for 60 s or 160 % for 10 s with a duty cycle duration of 300 s.

⁵⁾ Information regarding the correlation between the pulse frequency and max. output current/output frequency is provided in the SINAMICS Low Voltage Engineering Manual.

⁶⁾ The specified power loss represents the maximum value at 100% utilization. The value is lower under normal operating conditions.

⁷⁾ The value applies to coolants comprising water and a mixture of water and anti-freeze agent.

⁸⁾ The value is valid for water as coolant. [Additional information and notes on other coolants is provided in the SINAMICS Low Voltage Engineering Manual.](#)

⁹⁾ Total of all motor cables. Longer cable lengths for specific configurations are available on request. [For additional information, please refer to the SINAMICS Low Voltage Engineering Manual.](#)

Overview



Heat Exchanger Modules are used to dissipate the power loss from the converter. They comprise a deionized water circuit on the converter side and a raw water circuit on the plant side.

The hot deionized water in the circuit on the converter side passes through a maintenance-free circulating pump into the water/water plate-type heat exchanger. This is made of stainless steel and connected to the raw water circuit on the plant side. The deionized water is cooled there by the raw water of the outer circuit and flows back into the drive.

The closed converter-side deionized water circuit is filled with coolant in accordance with the requirements in section "Cooling circuit and coolant quality" and deaerated before commissioning. The pressure is maintained by means of an expansion chamber. Any residual air that arises in the circuit during operation is removed via automatic vents.

To avoid condensation at excessively low coolant temperatures, a three-way valve for controlling the coolant temperature is installed.

Heat Exchanger Modules are available for the following voltages and cooling power ratings:

Line voltage	Cooling power
380 ... 415 V 3 AC, 50 Hz	32 ... 110 kW
660 ... 690 V 3 AC, 50/60 Hz	32 ... 110 kW

Heat Exchanger Modules for other line voltages (up to 480 V or as of 500 V) and for 60 Hz are available on request.

Design

The deionized water is monitored by the drive itself to ensure intrinsic protection. The operating status is signaled to the drive.

Heat Exchanger Modules contain the following components as standard:

- 1 pump
- 1 stainless steel plate-type heat exchanger
- 1 three-way valve
- Filter, expansion chamber, vent, safety valve, pressure sensors, pressure display, temperature sensor, TM31 Terminal Module, LOGO control

Note:

Heat Exchanger Modules can only be located at the beginning or end of a cabinet row for technical reasons.

Selection and ordering data

Cooling power kW	Heat Exchanger Module Article No.
Line voltage 380 ... 415 V 3 AC, 50 Hz	
32	6SL3705-0RE23-2AA3
48	6SL3705-0RE24-8AA3
72	6SL3705-0RE27-2AA3
110	6SL3705-0RE31-1AA3
Line voltage 660 ... 690 V 3 AC, 50/60 Hz	
32	6SL3705-0RG23-2AA3
48	6SL3705-0RG24-8AA3
72	6SL3705-0RG27-2AA3
110	6SL3705-0RG31-1AA3

SINAMICS S120 Cabinet Modules

Liquid-cooled units

Heat Exchanger Modules

Integration

4

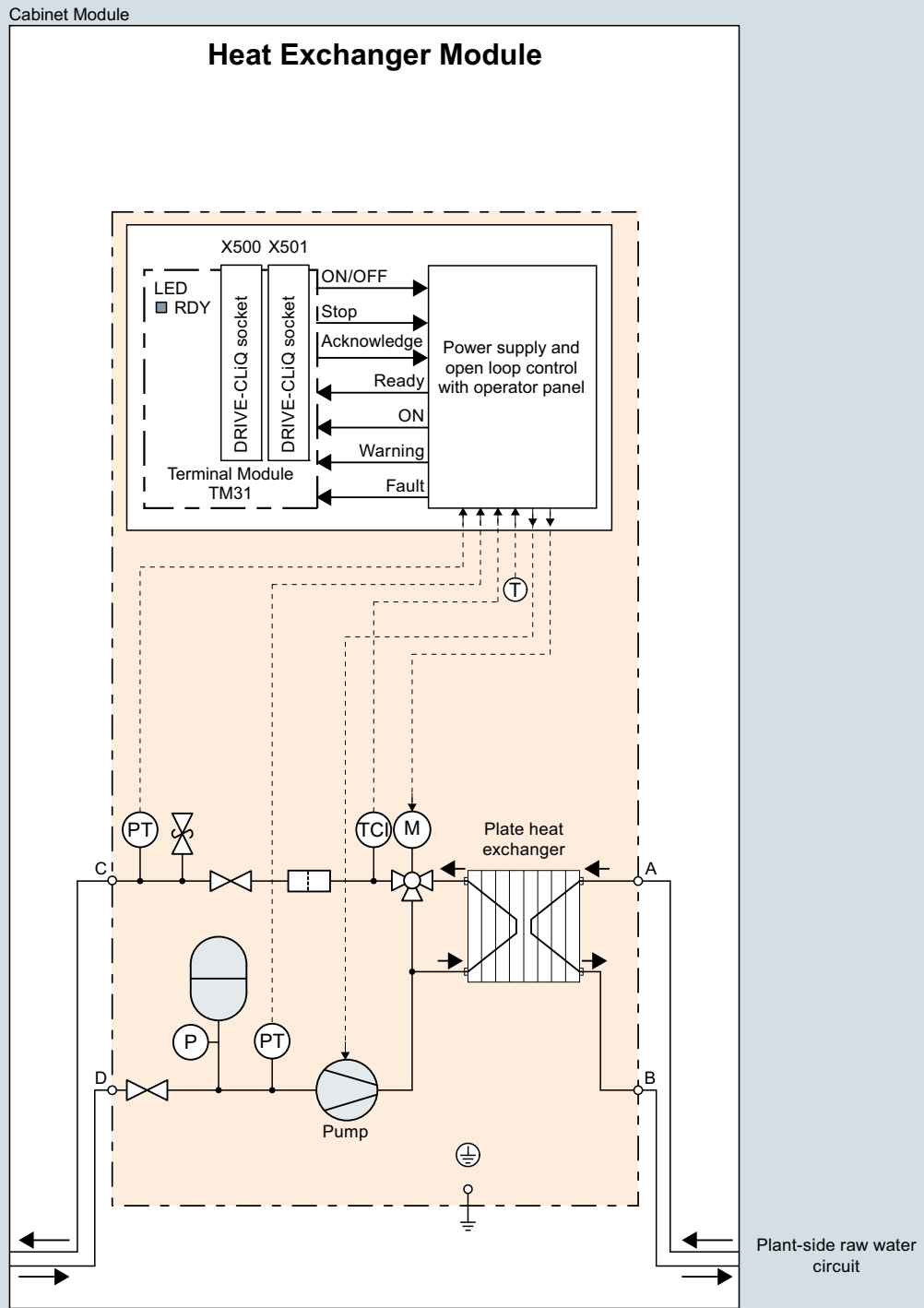

Connection example of the Heat Exchanger Module, liquid-cooled

Technical specifications

The Heat Exchanger Modules must be selected appropriately for the required cooling power and the required volume flow of coolant in the converter-side deionized water circuit. The values stated in the technical specifications of the Cabinet Modules for the heat loss dissipated into the coolant must be summated. The total value is then the required cooling power.

The volume flow of coolant stated in the technical data of the Cabinet Modules must also be added.

If either of the two total values exceeds the values defined in the technical specifications of the Heat Exchanger Module (cooling power and volume flow of coolant for converter-side deionized water), the next larger Heat Exchanger Module must be selected.

Line voltage 380 ... 415 V 3 AC 50 Hz		Heat Exchanger Modules			
		6SL3705-0RE23-2AA3	6SL3705-0RE24-8AA3	6SL3705-0RE27-2AA3	6SL3705-0RE31-1AA3
Cooling power	kW	32	48	72	110
Deionized water circuit (on the converter side)					
Inlet temperature		Depending on the ambient temperature and humidity of the air (see table for the dew point in section Liquid-cooled Cabinet Modules → Protection against condensation)			
• Min.	°C				
• Max.					
- Degree of protection <IP55	°C	45	45	45	45
- Degree of protection IP55	°C	40	40	40	40
Intake pressure					
• Min.	bar	1.7	1.7	1.7	1.7
• Max.	bar	6	6	6	6
Coolant volume flow ¹⁾	l/min	88	132	197	267
Liquid volume	l	18	25	43	47
Raw water circuit (on the plant side)					
Inlet temperature		Depending on the ambient temperature and humidity of the air (see table for the dew point in section Liquid-cooled Cabinet Modules → Protection against condensation)			
• Min.	°C	5 ²⁾	5 ²⁾	5 ²⁾	5 ²⁾
• Max.					
- Degree of protection <IP55	°C	38	38	38	38
- Degree of protection IP55	°C	33	33	33	33
Intake pressure, max.	bar	6	6	6	6
Coolant volume flow ¹⁾	l/min	132	198	263	445
General data					
Heat exchanger material		Stainless steel	Stainless steel	Stainless steel	Stainless steel
Current consumption					
• Operating current, total at 50 Hz 400 V	A	5.5	6.2	10.9	10.9
• Electronics current (24 V DC)	A	1.0	1.0	1.0	1.0
Power consumption	kW	1.3	1.7	4.2	4.2
Sound pressure level L_{pA} (1 m) at 50 Hz	dB	60	60	60	60
Line supply connection L1, L2, L3		Terminal	Terminal	Terminal	Terminal
• Conductor cross section, max. (IEC)	mm ²	4	4	4	4
PE/GND connection		Terminal	Terminal	Terminal	Terminal
• Conductor cross section, max. (IEC)	mm ²	4	4	4	4
Degree of protection (standard version)		IP21	IP21	IP21	IP21
Dimensions					
• Width	mm	800	1000	1200	1200
• Height	mm	2200	2200	2200	2200
• Depth	mm	600	600	600	600
Weight, approx. (standard version)	kg	540	565	608	628

¹⁾ The value is valid for water as coolant. For other coolants, see section Cooling circuit and coolant properties.

²⁾ 0 °C with anti-freeze (see derating characteristics).

SINAMICS S120 Cabinet Modules

Liquid-cooled units

Heat Exchanger Modules

Technical specifications (continued)

Line voltage 660 ... 690 V 3 AC 50/60 Hz		Heat Exchanger Modules			
		6SL3705-0RG23-2AA3	6SL3705-0RG24-8AA3	6SL3705-0RG27-2AA3	6SL3705-0RG31-1AA3
Cooling power	kW	32	48	72	110
Deionized water circuit (on the converter side)					
Inlet temperature					
• Min.	°C	Depending on the ambient temperature and humidity of the air (see table for the dew point in section Liquid-cooled Cabinet Modules → Protection against condensation)			
• Max.					
- Degree of protection <IP55	°C	45	45	45	45
- Degree of protection IP55	°C	40	40	40	40
Intake pressure					
• Min.	bar	1.7	1.7	1.7	1.7
• Max.	bar	6	6	6	6
Coolant volume flow ¹⁾	l/min	88	132	197	267
Liquid volume	l	18	25	43	47
Raw water circuit (on the plant side)					
Inlet temperature					
• Min.	°C	5 ²⁾	5 ²⁾	5 ²⁾	5 ²⁾
• Max.					
- Degree of protection <IP55	°C	38	38	38	38
- Degree of protection IP55	°C	33	33	33	33
Intake pressure, max.	bar	6	6	6	6
Coolant volume flow ¹⁾	l/min	132	198	263	445
General data					
Heat exchanger material		Stainless steel	Stainless steel	Stainless steel	Stainless steel
Current consumption					
• Operating current, total at 50/60 Hz 690 V	A	1.8/2.7	2.2/3.9	5.2/4.7	5.2/4.7
• Electronics current (24 V DC)	A	1.0	1.0	1.0	1.0
Power consumption at 50/60 Hz 690 V	kW	1.3/1.7	1.7/2.4	4.2/4.2	4.2/4.2
Sound pressure level L_{pA} (1 m) at 50/60 Hz	dB	60	60	60	60
Line supply connection L1, L2, L3		Terminal	Terminal	Terminal	Terminal
• Conductor cross section, max. (IEC)	mm ²	4	4	4	4
PE/GND connection		Terminal	Terminal	Terminal	Terminal
• Conductor cross section, max. (IEC)	mm ²	4	4	4	4
Degree of protection (standard version)		IP21	IP21	IP21	IP21
Dimensions					
• Width	mm	800	1000	1200	1200
• Height	mm	2200	2200	2200	2200
• Depth	mm	600	600	600	600
Weight, approx. (standard version)	kg	540	565	608	628

¹⁾ The value is valid for water as coolant. For other coolants, see section Cooling circuit and coolant properties.

²⁾ 0 °C with anti-freeze (see derating characteristics).

Overview

The following table provides an overview of all of the available options – and their assignment to the individual Cabinet Modules.

SINAMICS S120 Cabinet Modules		Air-cooled Cabinet Modules								Liquid-cooled Cabinet Modules				
Order code	Options	Line Connection Module	Basic Line Module	Smart Line Module	Active Line Module with Active Interface Module	Motor Module Booksize (Cabinet Kit)	Motor Module Booksize (Base Cabinet)	Motor Module Chassis	Central Braking Module	Auxiliary Power Supply Module	Basic Line Connection Module	Active Line Connection Module	Motor Module	Heat Exchanger Module
G20 ¹⁾	CBC10 Communication Board	-	✓	✓	✓	✓	-	✓	-	-	✓	✓	✓	-
G33 ¹⁾	CBE20 Communication Board	-	✓	✓	✓	✓	-	✓	-	-	✓	✓	✓	-
G51	1 x TM150 temperature sensor evaluation unit	✓	-	-	-	-	-	-	-	-	✓	✓	✓	-
G52	2 x TM150 temperature sensor evaluation units	✓	-	-	-	-	-	-	-	-	✓	✓	✓	-
G53	3 x TM150 temperature sensor evaluation units	✓	-	-	-	-	-	-	-	-	✓	✓	-	-
G54	4 x TM150 temperature sensor evaluation units	✓	-	-	-	-	-	-	-	-	✓	✓	-	-
G56	Contactor monitoring	-	✓	✓	✓ ²⁾	-	-	-	-	-	-	-	-	-
G60 ¹⁾	TM31 Terminal Module	-	-	-	-	-	-	-	-	-	✓	✓	✓	-
G61 ¹⁾	Additional TM31 Terminal Module	-	-	-	-	-	-	-	-	-	✓	✓	✓	-
G62 ¹⁾	TB30 Terminal Board	-	✓	✓	✓	✓	-	-	-	-	✓	✓	✓	-
K01 to K05	Safety license for 1 to 5 axes	-	-	-	-	✓	-	✓	-	-	-	-	✓	-
K08 ¹⁾	AOP30 Advanced Operator Panel installed in the cabinet door	-	✓	✓	✓	✓	-	✓	-	-	✓	✓	✓	-
K46	SMC10 Sensor Module Cabinet-Mounted	-	-	-	-	✓	-	✓	-	-	-	-	✓	-
K48	SMC20 Sensor Module Cabinet-Mounted	-	-	-	-	✓	-	✓	-	-	-	-	✓	-
K50	SMC30 Sensor Module Cabinet-Mounted	-	-	-	-	✓	-	✓	-	-	-	-	✓	-
K51	VSM10 Voltage Sensing Module	-	-	-	-	✓	-	✓	-	-	-	-	✓	-
K52	Second SMC30 Sensor Module Cabinet-Mounted	-	-	-	-	✓	-	✓	-	-	-	-	✓	-
K70	Fan power supply	✓	-	-	-	-	-	-	-	-	-	-	-	-
K73	SITOP power supply 24 V DC	-	-	-	-	✓	-	-	-	-	-	-	-	-
K76	Auxiliary power generation (in the Line Connection Module)	✓	-	-	-	-	-	-	-	-	✓	✓	-	-
K82	Terminal module for controlling the Safe Torque Off and Safe Stop 1 safety functions	-	-	-	-	✓	-	✓	-	-	-	-	-	-
K87	TM54F Terminal Module	-	-	-	-	✓	-	✓	-	-	-	-	✓	-
K88	Safe Brake Adapter 230 V AC	-	-	-	-	-	-	✓	-	-	-	-	-	-
K90	CU320-2 DP Control Unit	-	✓	✓	✓	✓	-	✓	-	-	✓	✓	✓	-
K94 ¹⁾	Performance expansion for CU320-2 Control Unit	-	✓	✓	✓	✓	-	✓	-	-	✓	✓	✓	-
K95	CU320-2 PN Control Unit	-	✓	✓	✓	✓	-	✓	-	-	✓	✓	✓	-

✓ Option can be ordered for this Cabinet Module
 - Option cannot be ordered for this Cabinet Module

SINAMICS S120 Cabinet Modules

Options

Overview (continued)

SINAMICS S120 Cabinet Modules		Air-cooled Cabinet Modules									Liquid-cooled Cabinet Modules			
Order code	Options	Line Connection Module	Basic Line Module	Smart Line Module	Active Line Module with Active Interface Module	Motor Module Booksize (Cabinet Kit)	Motor Module Booksize (Base Cabinet)	Motor Module Chassis	Central Braking Module	Auxiliary Power Supply Module	Basic Line Connection Module	Active Line Connection Module	Motor Module	Heat Exchanger Module
L00 ³⁾	Use in the "first environment" according to EN 61800-3, Category C2 (TN/TT supply systems with grounded neutral point)	✓	-	-	-	-	-	-	-	-	-	-	-	-
L07	dv/dt filter plus Voltage Peak Limiter	-	-	-	-	-	-	✓	-	-	-	-	-	-
L08	Motor reactor	-	-	-	-	✓	-	✓	-	-	-	-	-	-
L09	2 motor reactors connected in series	-	-	-	-	✓	-	-	-	-	-	-	-	-
L10	dv/dt filter plus Voltage Peak Limiter	-	-	-	-	-	-	✓	-	-	-	-	-	-
L13	Main contactor (for supply currents of ≤ 800 A)	✓ ⁴⁾	-	-	-	-	-	-	-	-	✓ ⁴⁾	-	-	-
L21	Surge suppression	✓	-	-	-	-	-	-	-	-	✓	✓	-	-
L22	Scope of delivery without line reactor	✓ ⁵⁾	-	✓	-	-	-	-	-	-	✓	✓	-	-
L25	Withdrawable circuit breaker in place of a fixed-mounted circuit breaker	✓ ⁶⁾	-	-	-	-	-	-	-	-	✓ ⁶⁾	✓ ⁶⁾	-	-
L34	Output-side circuit breaker (motor-driven)	-	-	-	-	-	-	✓	-	-	-	-	-	-
L37	DC interface incl. pre-charging circuit of the associated DC link capacitance	-	-	-	-	✓	-	✓	-	-	-	-	-	-
L40	Line filter monitoring	-	-	-	✓	-	-	-	-	-	-	✓	-	-
L41	Current transformer upstream of main circuit breaker	✓	-	-	-	-	-	-	-	-	✓	✓	-	-
L42	Line Connection Module for Active Line Modules	✓	-	-	-	-	-	-	-	-	-	-	-	-
L43	Line Connection Module for Basic Line Modules	✓	-	-	-	-	-	-	-	-	-	-	-	-
L44	Line Connection Module for Smart Line Modules	✓	-	-	-	-	-	-	-	-	-	-	-	-
L45	EMERGENCY OFF pushbutton installed in the cabinet door	✓	-	-	-	-	-	-	-	-	✓	✓	-	-
L46	Grounding switch upstream of main circuit breaker	✓ ⁷⁾	-	-	-	-	-	-	-	-	-	-	-	-
L47	Grounding switch downstream of main circuit breaker	✓ ⁷⁾	-	-	-	-	-	-	-	-	-	-	-	-
L50	Cabinet lighting with service socket	✓	-	-	-	-	-	-	-	-	✓	✓	-	-
L55	Cabinet anti-condensation heating	✓	✓	✓	✓	-	✓	✓	✓	✓	✓	✓	✓	✓
L61	25/125 kW braking unit (can be used for frame size FB) for line voltages of 380 ... 480 V and 660 ... 690 V	-	✓	-	✓	-	-	✓	-	-	-	-	-	-
L62	50/250 kW braking unit (can be used for frame size GB/GD) for line voltages of 380 ... 480 V and 660 ... 690 V	-	✓ ⁸⁾	✓	✓	-	-	✓	-	-	-	-	-	-
L64	25/125 kW braking unit (can be used for frame size FB) for line voltages of 500 ... 600 V	-	✓	-	✓	-	-	✓	-	-	-	-	-	-
L65	50/250 kW braking unit (can be used for frame size GB/GD) for line voltages of 500 ... 600 V	-	✓	✓	✓	-	-	✓	-	-	-	-	-	-
L87	Insulation monitoring	✓	-	-	-	-	-	-	-	-	✓	✓	-	-

✓ Option can be ordered for this Cabinet Module

- Option cannot be ordered for this Cabinet Module

For footnotes, see page 4/88.

Overview (continued)

SINAMICS S120 Cabinet Modules		Air-cooled Cabinet Modules								Liquid-cooled Cabinet Modules				
Order code	Options	Line Connection Module	Basic Line Module	Smart Line Module	Active Line Module with Active Interface Module	Motor Module Booksize (Cabinet Kit)	Motor Module Booksize (Base Cabinet)	Motor Module Chassis	Central Braking Module	Auxiliary Power Supply Module	Basic Line Connection Module	Active Line Connection Module	Motor Module	Heat Exchanger Module
M06	Base 100 mm high, RAL 7022	✓	✓	✓	✓	-	✓	✓	✓	✓	✓	✓	✓	✓
M07	Cable-marshaling space 200 mm high, RAL 7035	✓	✓	✓	✓	-	✓	✓	✓	✓	✓	✓	✓	✓
M21	Degree of protection IP21	✓	✓	✓	✓	-	-	-	-	-	-	-	-	-
M23	Degree of protection IP23 (includes M60)	✓	✓	✓	✓	-	✓	✓	✓	✓	✓	✓	✓	✓
M26	Side panel mounted to the right	-	✓	✓	✓	-	✓	✓	✓	✓	✓	✓	✓	✓
M27	Side panel mounted to the left	✓	✓	✓	✓	-	✓	✓	✓	✓	✓	✓	✓	✓
M43	Degree of protection IP43 (includes M60)	✓	✓	✓	✓	-	✓	✓	✓	✓	✓	✓	✓	✓
M51	Motor connection wired to customer terminal	-	-	-	-	✓	-	-	-	-	-	-	-	-
M54	Degree of protection IP54 (includes M60)	✓	✓	✓	✓	-	✓	✓	✓	✓	-	-	-	-
M55	Degree of protection IP55	-	-	-	-	-	-	-	-	-	✓	✓	✓	✓
M56	Reinforced mechanical design	✓	✓	✓	✓	-	✓	✓	✓	✓	-	-	-	-
M59	Closed cabinet door, air intake from below through floor opening	✓	✓	✓	✓	-	✓	✓	✓	✓	-	-	-	-
M60 ⁹⁾	Additional touch protection (included in M23 , M43 , and M54)	✓	✓	✓	✓	-	-	✓	-	-	-	-	-	-
M70	EMC shield bus	✓	-	-	-	-	✓	✓	-	✓	✓	✓	✓	-
M72	Quick-release couplings for water hoses	-	-	-	-	-	-	-	-	-	✓	✓	✓	-
M77	Version without component support plates and without additional control components	-	-	-	-	-	✓	-	-	-	-	-	-	-
M90	Crane transport assembly (top-mounted)	✓	✓	✓	✓	-	✓	✓	✓	✓	✓	✓	✓	✓
M91	Marking of all control cable wire ends (including customer-specific cables)	✓	✓	✓	✓	-	✓	✓	✓	✓	✓	✓	✓	-
N52	DC link fuses	-	✓	-	-	-	-	-	-	-	✓	✓	-	-
P10	Measuring instrument for line supply values; mounted in cabinet door (includes L41)	✓	-	-	-	-	-	-	-	-	✓	✓	-	-
P11	Measuring instrument for line supply values like option P10 , with PROFIBUS connection	✓	-	-	-	-	-	-	-	-	✓	✓	-	-
W01	Partially redundant cooling unit with 2 pumps and 1 stainless steel plate-type heat exchanger	-	-	-	-	-	-	-	-	-	-	-	-	✓
W20	Raw-water connection from the bottom	-	-	-	-	-	-	-	-	-	-	-	-	✓
Y09	Special paint finish for cabinet	✓	✓	✓	✓	-	✓	✓	✓	✓	✓	✓	✓	✓
Y11	Factory-assembled transport units	✓	✓	✓	✓	-	✓	✓	✓	✓	✓	✓	✓	✓

✓ Option can be ordered for this Cabinet Module
 - Option cannot be ordered for this Cabinet Module

SINAMICS S120 Cabinet Modules

Options

Overview (continued)

SINAMICS S120 Cabinet Modules		Air-cooled Cabinet Modules									Liquid-cooled Cabinet Modules			
		Line Connection Module	Basic Line Module	Smart Line Module	Active Line Module with Active Interface Module	Motor Module Booksize (Cabinet Kit)	Motor Module Booksize (Base Cabinet)	Motor Module Chassis	Central Braking Module	Auxiliary Power Supply Module	Basic Line Connection Module	Active Line Connection Module	Motor Module	Heat Exchanger Module
Order code	Options													
Production flowcharts														
B43	Document - Production flowchart: One issue	✓	✓	✓	✓	–	✓	✓	✓	✓	✓	✓	✓	✓
B44	Document - Production flowchart: Updated every two weeks	✓	✓	✓	✓	–	✓	✓	✓	✓	✓	✓	✓	✓
B45	Document - Production flowchart: Updated every month	✓	✓	✓	✓	–	✓	✓	✓	✓	✓	✓	✓	✓
Mechanical options for DC busbar system														
M80	DC busbar system ($I_d = 1170$ A, $1 \times 60 \times 10$ mm)	✓	✓	✓	✓	–	✓	✓	✓	✓	✓	✓	✓	–
M81	DC busbar system ($I_d = 1500$ A, $1 \times 80 \times 10$ mm)	✓	✓	✓	✓	–	✓	✓	✓	✓	✓	✓	✓	–
M82	DC busbar system ($I_d = 1840$ A, $1 \times 100 \times 10$ mm)	✓	✓	✓	✓	–	✓	✓	✓	✓	✓	✓	✓	–
M83	DC busbar system ($I_d = 2150$ A, $2 \times 60 \times 10$ mm)	✓	✓	✓	✓	–	✓	✓	✓	✓	✓	✓	✓	–
M84	DC busbar system ($I_d = 2730$ A, $2 \times 80 \times 10$ mm)	✓	✓	✓	✓	–	✓	✓	✓	✓	✓	✓	✓	–
M85	DC busbar system ($I_d = 3320$ A, $2 \times 100 \times 10$ mm)	✓	✓	✓	✓	–	✓	✓	✓	✓	✓	✓	✓	–
M86	DC busbar system ($I_d = 3720$ A, $3 \times 80 \times 10$ mm)	✓	✓	✓	✓	–	✓	✓	✓	✓	✓	✓	✓	–
M87	DC busbar system ($I_d = 4480$ A, $3 \times 100 \times 10$ mm)	✓	✓	✓	✓	–	✓	✓	✓	✓	✓	✓	✓	–
M88	DC busbar system for line-side Cabinet Modules	–	–	–	–	–	–	–	–	–	✓	✓	–	–
✓	Option can be ordered for this Cabinet Module													
–	Option cannot be ordered for this Cabinet Module													

Overview (continued)

SINAMICS S120 Cabinet Modules		Air-cooled Cabinet Modules									Liquid-cooled Cabinet Modules			
		Line Connection Module	Basic Line Module	Smart Line Module	Active Line Module with Active Interface Module	Motor Module Booksize (Cabinet Kit)	Motor Module Booksize (Base Cabinet)	Motor Module Chassis	Central Braking Module	Auxiliary Power Supply Module	Basic Line Connection Module	Active Line Connection Module	Motor Module	Heat Exchanger Module
Order code	Options													
Documentation														
D00	Documentation in German	✓	✓	✓	✓	–	✓	✓	✓	✓	✓	✓	✓	
D02	Customer documentation (circuit diagram, terminal diagram, layout diagram) in DXF format	✓	✓	✓	✓	–	✓	✓	✓	✓	✓	✓	✓	
D14	Preliminary version of customer documentation in PDF format	✓	✓	✓	✓	–	✓	✓	✓	✓	✓	✓	✓	
D56	Documentation in Russian	✓	✓	✓	✓	–	✓	✓	✓	✓	✓	✓	✓	
D58	Documentation in English / French	✓	✓	✓	✓	–	✓	✓	✓	✓	✓	✓	✓	
D60	Documentation in English / Spanish	✓	✓	✓	✓	–	✓	✓	✓	✓	✓	✓	✓	
D72	Documentation in Italian	✓	✓	✓	✓	–	✓	✓	✓	✓	✓	✓	✓	
D76	Documentation in English	✓	✓	✓	✓	–	✓	✓	✓	✓	✓	✓	✓	
D77	Documentation in French	✓	✓	✓	✓	–	✓	✓	✓	✓	✓	✓	✓	
D78	Documentation in Spanish	✓	✓	✓	✓	–	✓	✓	✓	✓	✓	✓	✓	
D80	Documentation in English / Italian	✓	✓	✓	✓	–	✓	✓	✓	✓	✓	✓	✓	
D84	Documentation in Chinese	✓	✓	✓	✓	–	✓	✓	✓	✓	✓	✓	✓	
D91	Documentation in English / Chinese	✓	✓	✓	✓	–	✓	✓	✓	✓	✓	✓	✓	
D93	Documentation in English / Portuguese (Brazil)	✓	✓	✓	✓	–	✓	✓	✓	✓	–	–	–	
D94	Documentation in English / Russian	✓	✓	✓	✓	–	✓	✓	✓	✓	✓	✓	✓	
D99	Without operating instructions	✓	✓	✓	✓	–	✓	✓	✓	✓	✓	✓	✓	
Labeling plates														
T58	Rating plate data in English/French	✓	✓	✓	✓	–	✓	✓	✓	✓	✓	✓	✓	
T60	Rating plate data in English/Spanish	✓	✓	✓	✓	–	✓	✓	✓	✓	✓	✓	✓	
T80	Rating plate data in English/Italian	✓	✓	✓	✓	–	✓	✓	✓	✓	✓	✓	✓	
T83	Rating plate data in English/Portuguese (Brazil)	✓	✓	✓	✓	–	✓	✓	✓	✓	–	–	–	
T85	Rating plate data in English/Russian	✓	✓	✓	✓	–	✓	✓	✓	✓	✓	✓	✓	
T91	Rating plate data in English/Chinese	✓	✓	✓	✓	–	✓	✓	✓	✓	✓	✓	✓	
Y31	One-line label for system identification, 40 × 80 mm	✓	✓	✓	✓	–	✓	✓	✓	✓	✓	✓	✓	
Y32	Two-line label for system identification, 40 × 180 mm	✓	✓	✓	✓	–	✓	✓	✓	✓	✓	✓	✓	
Y33	Four-line label for system identification, 40 × 180 mm	✓	✓	✓	✓	–	✓	✓	✓	✓	✓	✓	✓	
✓	Option can be ordered for this Cabinet Module													
–	Option cannot be ordered for this Cabinet Module													

SINAMICS S120 Cabinet Modules

Options

Overview (continued)

SINAMICS S120 Cabinet Modules		Air-cooled Cabinet Modules									Liquid-cooled Cabinet Modules			
		Line Connection Module	Basic Line Module	Smart Line Module	Active Line Module with Active Interface Module	Motor Module Booksize (Cabinet Kit)	Motor Module Booksize (Base Cabinet)	Motor Module Chassis	Central Braking Module	Auxiliary Power Supply Module	Basic Line Connection Module	Active Line Connection Module	Motor Module	Heat Exchanger Module
Order code	Options													
Converter acceptance inspection														
F03	Visual acceptance	✓	✓	✓	✓	–	✓	✓	✓	✓	✓	✓	✓	✓
F71	Function test without motor (witnessed by customer)	✓	✓	✓	✓	–	✓	✓	✓	✓	✓	✓	✓	✓
F72	Function test without motor (not witnessed by customer)	✓	✓	✓	✓	–	✓	✓	✓	✓	✓	✓	✓	✓
F74	Function test with test bay motor (not witnessed by customer) ¹⁰⁾	✓	✓	✓	✓	–	✓	✓	–	–	✓	✓	✓	✓
F75	Function test with test bay motor (witnessed by customer) ¹⁰⁾	✓	✓	✓	✓	–	✓	✓	–	–	✓	✓	✓	✓
F76	Insulation test (not witnessed by customer)	✓	✓	✓	✓	–	✓	✓	✓	✓	✓	✓	✓	✓
F77	Insulation test (witnessed by customer)	✓	✓	✓	✓	–	✓	✓	✓	✓	✓	✓	✓	✓
F97	Customer-specific acceptance inspections (on request)	✓	✓	✓	✓	–	✓	✓	✓	✓	✓	✓	✓	✓
✓	Option can be ordered for this Cabinet Module													
–	Option cannot be ordered for this Cabinet Module													

¹⁾ Only in conjunction with option **K90** or **K95**.

²⁾ Option **G56** cannot be selected for Active Line Modules in frame sizes FX and GX.

³⁾ For Basic Line Modules for cable lengths < 100 m. Not for a parallel connection of Line Modules to a common Line Connection Module.

⁴⁾ For rated currents ≤ 800 A.

⁵⁾ Only with option **L43** (for Basic Line Modules) and for rated currents ≤ 2000 A.

⁶⁾ For rated currents ≥ 800 A.

⁷⁾ For rated currents ≥ 2000 A.

⁸⁾ When Basic Line Modules are connected in parallel with a Line Connection Module, there is only space to fit a braking unit in the right-hand Basic Line Module.

⁹⁾ Can only be ordered for air-cooled Cabinet Modules. Liquid-cooled Cabinet Modules incorporate additional touch protection as a standard feature.

¹⁰⁾ For a function test with test-bay motor, the motor is connected to Motor Modules in chassis format and/or Motor Modules in booksize format in the Base Cabinet.

Overview (continued)*Option selection matrix*

Certain options are mutually exclusive. Options that are not affected are not shown.

✓	Possible combination
–	Combination not possible

Electrical options

	G20	G33	G62	K90	K95
G20		–	–	✓	✓
G33	–		–	✓	✓
G62	–	–		✓	✓
K90	✓	✓	✓		–
K95	✓	✓	✓	–	

	L61/64	L62/65
L61/64		–
L62/65	–	

	K46	K48	K50	K51	K52	K88	L07	L08	L09 ¹⁾	L10	L34	L37
K46		–	–	–	–	✓	✓	✓	✓	✓	✓	✓
K48	–		–	–	–	✓	✓	✓	✓	✓	✓	✓
K50	–	–		–	✓	✓	✓	✓	✓	✓	✓	✓
K51	–	–	–		–	✓	✓	✓	✓	✓	✓	✓
K52	–	–	✓	–		✓	✓	✓	✓	✓	✓	✓
K88	✓	✓	✓	✓	✓		✓	✓	✓	✓	✓	✓
L07	✓	✓	✓	✓	✓	✓		–	–	–	–	✓
L08	✓	✓	✓	✓	✓	✓	–		–	–	✓	✓
L09 ¹⁾	✓	✓	✓	✓	✓	✓	–	–		–	–	✓
L10	✓	✓	✓	✓	✓	✓	–	–	–		–	✓
L34	✓	✓	✓	✓	✓	✓	–	✓	–	–		✓
L37	✓	✓	✓	✓	✓	✓	✓	✓	✓	✓	✓	

¹⁾ Option for Booksize Cabinet Kit only.

Electrical options (Line Connection Module)

	K76	L13 ¹⁾	L25 ²⁾	L41	L46 ³⁾	L47 ³⁾	P10	P11
K76		✓	✓	✓	–	✓	✓	✓
L13 ¹⁾	✓		–	✓	–	–	✓	✓
L25 ²⁾	✓	–		✓	✓	✓	✓	✓
L41	✓	✓	✓		–	–	–	–
L46 ³⁾	–	–	✓	✓		✓	✓	✓
L47 ³⁾	✓	–	✓	✓	–		✓	✓
P10	✓	✓	✓	–	✓	✓		–
P11	✓	✓	✓	–	✓	✓	–	

¹⁾ Option for rated currents of ≤800 A only.

²⁾ Option for rated currents of >800 A only.

³⁾ Option for rated currents of ≥2000 A only.

SINAMICS S120 Cabinet Modules

Options

Overview (continued)

Mechanical/electrical options

	L22	L42	L43	L44	M06	M07	M21	M23	M26	M27	M43	M54	M55	M60	M90	Y11	Y31	Y32	Y33	
L22	✓	–	✓	–	✓	✓	✓	✓	✓	✓	✓	✓	✓	✓	✓	✓	✓	✓	✓	✓
L42	–	✓	–	–	✓	✓	✓	✓	✓	✓	✓	✓	–	✓	✓	✓	✓	✓	✓	✓
L43	✓	–	✓	–	✓	✓	✓	✓	✓	✓	✓	✓	–	✓	✓	✓	✓	✓	✓	✓
L44	–	–	–	✓	✓	✓	✓	✓	✓	✓	✓	✓	–	✓	✓	✓	✓	✓	✓	✓
M06	✓	✓	✓	✓	–	–	✓	✓	✓	✓	✓	✓	✓	✓	✓	✓	✓	✓	✓	✓
M07	✓	✓	✓	✓	–	–	✓	✓	✓	✓	✓	✓	✓	✓	✓	✓	✓	✓	✓	✓
M21	✓	✓	✓	✓	✓	✓	–	–	✓	✓	–	–	–	✓	✓	✓	✓	✓	✓	✓
M23	✓	✓	✓	✓	✓	✓	–	–	✓	✓	–	–	–	– ¹⁾	✓	✓	✓	✓	✓	✓
M26	✓	✓	✓	✓	✓	✓	✓	✓	–	–	✓	✓	✓	✓	✓	✓	✓	✓	✓	✓
M27	✓	✓	✓	✓	✓	✓	✓	✓	–	–	✓	✓	✓	✓	✓	✓	✓	✓	✓	✓
M43	✓	✓	✓	✓	✓	✓	–	–	✓	✓	–	–	–	– ¹⁾	✓	✓	✓	✓	✓	✓
M54	✓	✓	✓	✓	✓	✓	–	–	✓	✓	–	–	–	– ¹⁾	✓	✓	✓	✓	✓	✓
M55	✓	–	–	–	✓	✓	–	–	✓	✓	–	–	–	–	✓	✓	✓	✓	✓	✓
M60	✓	✓	✓	✓	✓	✓	– ¹⁾	–	✓	✓	– ¹⁾	– ¹⁾	–	–	✓	✓	✓	✓	✓	✓
M90	✓	✓	✓	✓	✓	✓	✓	✓	✓	✓	✓	✓	✓	✓	–	–	✓	✓	✓	✓
Y11	✓	✓	✓	✓	✓	✓	✓	✓	✓	✓	✓	✓	✓	✓	–	–	✓	✓	✓	✓
Y31	✓	✓	✓	✓	✓	✓	✓	✓	✓	✓	✓	✓	✓	✓	✓	✓	–	–	–	–
Y32	✓	✓	✓	✓	✓	✓	✓	✓	✓	✓	✓	✓	✓	✓	✓	✓	–	–	–	–
Y33	✓	✓	✓	✓	✓	✓	✓	✓	✓	✓	✓	✓	✓	✓	✓	✓	–	–	–	–

¹⁾ Option **M60** is already included in **M23**, **M43**, and **M54** for all Line Modules and Motor Modules in chassis format.

DC busbar system mechanical options (busbars between individual Cabinet Modules)

	M80	M81	M82	M83	M84	M85	M86	M87
M80	–	–	–	✓	–	–	–	–
M81	–	–	–	–	✓	–	✓	–
M82	–	–	–	–	–	✓	–	✓
M83	✓	–	–	–	–	–	–	–
M84	–	✓	–	–	–	–	✓	–
M85	–	–	✓	–	–	–	–	✓
M86	–	✓	–	–	✓	–	–	–
M87	–	–	✓	–	–	✓	–	–

Documentation

	D00	D02	D14	D56	D58	D60	D72	D76	D77	D78	D80	D84	D91	D94	D99
D00	–	✓	✓	✓	✓	✓	✓	✓	✓	✓	✓	✓	✓	✓	–
D02	✓	–	✓	✓	✓	✓	✓	✓	✓	✓	✓	✓	✓	✓	–
D14	✓	✓	–	✓	✓	✓	✓	✓	✓	✓	✓	✓	✓	✓	–
D56	✓	✓	✓	–	✓	✓	✓	✓	✓	✓	✓	✓	✓	–	–
D58	✓	✓	✓	✓	–	–	✓	–	–	✓	–	✓	–	–	–
D60	✓	✓	✓	✓	–	–	✓	–	✓	–	–	✓	–	–	–
D72	✓	✓	✓	✓	✓	✓	–	✓	✓	✓	–	✓	✓	✓	–
D76	✓	✓	✓	✓	–	–	✓	–	✓	✓	–	✓	–	–	–
D77	✓	✓	✓	✓	–	–	✓	✓	–	✓	✓	✓	✓	✓	–
D78	✓	✓	✓	✓	✓	–	✓	✓	✓	–	✓	✓	✓	✓	–
D80	✓	✓	✓	✓	–	–	–	–	✓	✓	–	✓	–	–	–
D84	✓	✓	✓	✓	✓	✓	✓	✓	✓	✓	–	–	–	✓	–
D91	✓	✓	✓	✓	–	–	✓	–	✓	✓	–	–	–	–	–
D94	✓	✓	✓	–	–	–	✓	–	✓	✓	–	✓	–	–	–
D99	–	–	–	–	–	–	–	–	–	–	–	–	–	–	–

Options

B43, B44, B45
Production flowcharts

Production flowcharts are provided with options **B43** to **B45**. After the order has been clarified, these are emailed as a dual language (English/German) PDF file.

Option	Description
B43	Documentation - Production flowchart: one issue
B44	Documentation - Production flowchart: updated every two weeks
B45	Documentation - Production flowchart: updated every month

D02
Customer documentation (circuit diagram, terminal diagram, layout diagram) in DXF format

Option **D02** can be used to order documents such as circuit diagrams, terminal diagrams, layout diagrams, and dimension drawings in DXF format, e.g. for further processing in CAD systems.

D14
Preliminary version of customer documentation in PDF format

If documents such as circuit diagrams, terminal diagrams, layout diagrams and dimension drawings are required in advance for the purpose of system engineering (integration of drive into higher-level systems, interface definition, installation, building planning, etc.), it is possible to order a draft copy of the documentation when ordering the Cabinet Modules. These documents are then supplied electronically a few working days following receipt of the order. If the order includes options that fall outside the scope of standard delivery, these will not be covered by the documentation due to the obvious time constraints.

Documentation relating to the order is sent to the buyer by email. The recipient's email address must be specified with the order for this purpose. In the email, the recipient will also receive a link (Internet address) for downloading general, non-order-specific documentation such as the Operating Instructions, Equipment Manual and Commissioning Instructions.

F03, F71, F72, F74, F75, F76, F77, F97
Converter acceptance inspections

Order code	Description
F03	<p>Visual acceptance</p> <p>The inspection includes the following:</p> <ul style="list-style-type: none"> • Check of degree of protection • Check of equipment (components) • Check of equipment identifiers • Check of clearance and creepage distances • Check of cables • Check of customer documentation • Submission of the acceptance report <p>All the above checks are performed with the equipment in a no-voltage condition.</p>

D58, D60, D80, D91, D93, D94
Documentation as language package

If a documentation option is not selected, the relevant documentation is supplied as standard in English/German. When one of the options specified in the table is selected, the standard documentation language will be changed from English / German to the language combination provided by the option.

Order code	Language
D58	English/French
D60	English/Spanish
D80	English/Italian
D91	English/Chinese
D93	English/Portuguese (Brazil)
D94	English/Russian

D00, D56, D72, D76, D77, D78, D84
Documentation in a single language

The documentation is also available in a single language, for example, to be able to order other language combinations.

If a further language is required for standard documentation in English/German, the option **D74** (documentation in English/German) must also be ordered in addition to that language.

Order code	Language
D00	German
D56	Russian
D72	Italian
D76	English
D77	French
D78	Spanish
D84	Chinese

D99
Without operating instructions

The Cabinet Modules or Booksize Cabinet Kit are shipped without a documentation CD.

Order code	Description
F71 (witnessed by customer) F72 (not witnessed by customer)	<p>Function test without motor</p> <p>After the visual acceptance with the converter switched off, the converter is connected to rated voltage. No current at the converter output end.</p> <p>The inspection includes the following:</p> <ul style="list-style-type: none"> • Visual acceptance as described for option F03 • Check of power supply • Check of protective and monitoring devices (simulation) • Check of fans • Pre-charging test • Function test without connected motor • Submission of the acceptance report

SINAMICS S120 Cabinet Modules

Options

Options (continued)

Order code	Description
F74 (not witnessed by customer) F75 (witnessed by customer)	Function test with test bay motor under no-load conditions After the visual acceptance with the converter switched off, the converter is connected to rated voltage. A small current flows at the converter output end in order to operate the test bay motor under no-load conditions. The inspection includes the following: <ul style="list-style-type: none"> • Visual acceptance as described for option F03 • Check of power supply • Check of protective and monitoring devices (simulation) • Check of fans • Function test with test bay motor under no-load conditions • Submission of the acceptance report
F76 (not witnessed by customer) F77 (witnessed by customer)	Insulation test of the equipment The inspection includes the following: <ul style="list-style-type: none"> • High-voltage test • Measurement of the insulation resistance • Submission of the acceptance report
F97	Customer-specific acceptance inspections (on request) If acceptance inspections that are not covered by the options F03 , F71/F72 , F74/F75 or F76/F77 are required, then customer-specific acceptance inspections/supplementary tests can be ordered using order code F97 on request and following technical clarification.

G20 **CBC10 Communication Board**

The CBC10 Communication Board is used to interface the CU320-2 Control Unit and thus the SINAMICS S120 Cabinet Modules to the CAN (Controller Area Network) protocol. The associated driver software fulfills the standards of the following CANopen specification of the CiA organization (CAN in Automation):

- Communication profiles according to DS 301
- Drive profile in accordance with DSP 402 (in this case Profile Velocity Mode)
- EDS (Electronic Data Sheet) in accordance with DSP 306
- Operational state signaling according to DSP 305

The CBC10 Communication Board plugs into the option slot on the CU320-2 Control Unit. The CAN interface on the CBC10 has 2 SUB-D connections for input and output.

The CBC10 Communication Board can only be ordered in conjunction with a CU320-2 Control Unit (option **K90** or **K95**). A combination with options **G33** and **G62** is not possible.

[Description of the CBC10 Communication Board](#) → [Chassis format units](#) → [System components](#) → [Supplementary system components](#).

G33 **CBE20 Communication Board**

The CBE20 Communication Board can be used to connect the SINAMICS S120 Cabinet Modules to a PROFINET-IO or EtherNet/IP network via a CU320-2 Control Unit. The CBE20 Communication Board plugs into the option slot on the CU320-2 Control Unit.

The CBE20 Communication Board can only be ordered as option **G33** in conjunction with a CU320-2 Control Unit (option **K90** or **K95**) and is supplied in an accessories pack for possible configuration. A combination with options **G20** and **G62** is not possible.

Note:

Only one communication interface can be used in isochronous operation when operating the Communication Board CBE20 in a Control Unit CU320-2.

- CU320-2 DP: Either the DP interface of the Control Unit or the PN interfaces of the CBE20
- CU320-2 PN: Either the internal PN interfaces or the external PN interfaces of the CBE20

[Description of the CBE20 Communication Board](#) → [Chassis format units](#) → [System components](#) → [Supplementary system components](#).

Options (continued)**G51 to G54****TM150 temperature sensor evaluation unit**

Options **G51** to **G54** can be used to order between one and four TM150 Terminal Modules for sensing and evaluating several temperature sensors.

Order code	Option
G51	1 x TM150 temperature sensor evaluation unit
G52	2 x TM150 temperature sensor evaluation units
G53	3 x TM150 temperature sensor evaluation units
G54	4 x TM150 temperature sensor evaluation units

The TM150 Terminal Module is a DRIVE-CLiQ component for temperature evaluation. The temperature is measured in a temperature range from -99 °C to +250 °C for the following temperature sensors:

- Pt100 (with monitoring for wire breaks and short-circuits)
- Pt1000 (with monitoring for wire breaks and short-circuits)
- KTY84 (with monitoring for wire breaks and short-circuits)
- PTC (with monitoring for short-circuits)
- Bimetallic NC contact (without monitoring)

For the temperature sensor inputs, the evaluation can be parameterized for 1x2-wire, 2x2-wire, 3-wire or 4-wire for each terminal block. There is no electrical isolation in the TM150.

A maximum of 12 temperature sensors can be connected to the TM150 Terminal Module.

[Description of the TM150 Terminal Module](#) → [SINAMICS S120 chassis format units](#) → [System components](#) → [Supplementary system components](#).

G56**Contactors monitoring**

The option is used for monitoring the pre-charging and bypass contactors of the Line Modules, mainly for infeeds connected in parallel.

Note:

Option **G56** cannot be selected for Active Line Modules in frame sizes FX and GX.

G60**TM31 Terminal Module**

The TM31 Terminal Module is used to expand the customer terminal.

The following additional interfaces are available:

- 8 digital inputs
- 4 bidirectional digital inputs/outputs
- 2 relay outputs with changeover contact
- 2 analog inputs
- 2 analog outputs
- 1 temperature sensor input (KTY84-130/PTC)
- 2 DRIVE-CLiQ sockets
- 1 connection for the electronics power supply via the 24 V DC supply connector
- 1 PE connection

To simplify configuration and commissioning of the drive, the optional TM31 Terminal Module is already preset with various factory settings, which can then be selected when commissioning the system.

[Description of the TM31 Terminal Module](#) → [SINAMICS S120 chassis format units](#) → [System components](#) → [Supplementary system components](#).

For additional information, please refer to the [SINAMICS Low Voltage Engineering Manual](#).

G61**Additional TM31 Terminal Module**

With option **G61**, the number of digital inputs/outputs, as well as the number of analog inputs/outputs in the drive system can be expanded using a second TM31 Terminal Module (in addition to the TM31 Terminal Module that can be selected using option **G60**).

Note:

Option **G61** requires option **G60**.

G62**TB30 Terminal Board**

The TB30 Terminal Board provides a way of adding digital inputs/digital outputs and analog inputs/analog outputs to the Control Unit. The TB30 Terminal Board plugs into the option slot on the Control Unit.

The following are located on the TB30 Terminal Board:

- Power supply for digital inputs/digital outputs
- 4 digital inputs
- 4 digital outputs
- 2 analog inputs
- 2 analog outputs

The TB30 Terminal Board can only be ordered in conjunction with a CU320-2 Control Unit (option **K90** or **K95**). A combination with options **G20** and **G33** is not possible.

[Description of the TB30 Terminal Board](#) → [SINAMICS S120 chassis format units](#) → [System components](#) → [Supplementary system components](#).

SINAMICS S120 Cabinet Modules

Options

Options (continued)

K01 to K05

Safety license for 1 to 5 axes

The Safety Integrated basic functions do not require a license. In the case of Safety Integrated Extended Functions, however, a license is required for each axis equipped with safety functions. It is irrelevant which safety functions are used and how many.

Option **K01** includes the license for 1 axis, **K02** for 2 axes, etc. up to option **K05** for 5 axes.

The required licenses can be optionally ordered with the CompactFlash card.

Subsequent licensing is possible online via the WEB License Manager by generating a license key:

www.siemens.com/automation/license

K08

AOP30 Advanced Operator Panel installed in the cabinet door

The AOP30 Advanced Operator Panel is an optional input/output device for the Cabinet Modules. If, for the Cabinet Module or the Booksize Cabinet Kit, an autonomous closed-control (option **K90** or **K95**) is selected, this module can be assigned to its own operator panel with option **K08**.

The AOP30 Advanced Operator Panel is installed in the cabinet door of each Cabinet Module.

[Description of the AOP30 → Chassis format units → System components → Supplementary system components.](#)

K46

SMC10 Sensor Module Cabinet-Mounted

The SMC10 Sensor Module Cabinet-Mounted can be used to simultaneously sense the speed and the rotor position angle. The signals received from the resolver are converted here and made available to the closed-loop controller via the DRIVE-CLiQ interface for evaluation purposes.

The following encoder signals can be evaluated:

- 2-pole resolver
- Multi-pole resolver

The motor temperature can also be measured using KTY84-130 or PTC thermistors.

[Description of the SMC10 Sensor Module Cabinet-Mounted → Chassis format units → System components → Supplementary system components.](#)

K48

SMC20 Sensor Module Cabinet-Mounted

The SMC20 Sensor Module Cabinet-Mounted can be used to simultaneously sense the speed and position. The signals received from the incremental encoder are converted here and made available to the closed-loop controller via the DRIVE-CLiQ interface for evaluation purposes.

The following encoder signals can be evaluated:

- Incremental encoder sin/cos 1 V_{pp}
- Absolute encoder EnDat 2.1
- SSI encoder with incremental signals sin/cos 1 V_{pp}

The motor temperature can also be measured using KTY84-130 or PTC thermistors.

[Description of the SMC20 Sensor Module → Chassis format units → System components → Supplementary system components.](#)

K50

SMC30 Sensor Module Cabinet-Mounted

The SMC30 Sensor Module Cabinet-Mounted can be used to evaluate the encoders of motors without a DRIVE-CLiQ interface. External encoders can also be connected via the SMC30.

The following encoder signals can be evaluated:

- Incremental encoders TTL/HTL with and without open-circuit detection (open-circuit detection is only available with bipolar signals)
- SSI encoders with TTL/HTL incremental signals
- SSI encoders without incremental signals

The motor temperature can also be measured using KTY84-130 or PTC thermistors.

[Description of the SMC30 Sensor Module → Chassis format units → System components → Supplementary system components.](#)

K51

VSM10 Voltage Sensing Module

The VSM10 Voltage Sensing Module is used to measure the voltage characteristic on the motor side, so that the following function can be implemented:

- Operation of a permanent-magnet synchronous motor without encoder with the requirement to be able to connect to a motor that is already running (flying restart function)
- Quick flying restart of large induction motors: The voltage sensing function eliminates the delay incurred by demagnetization of the motor.

[Description of the VSM10 Voltage Sensing Module → Chassis format units → System components → Supplementary system components.](#)

K52

Second SMC30 Sensor Module Cabinet-Mounted

With option **K50**, the cabinet unit contains an SMC30 Sensor Module Cabinet-Mounted. An additional SMC30 (option **K52**) enables reliable actual-value acquisition when Safety Integrated extended functions are used (requires a license: options **K01** to **K05**).

Detailed and comprehensive instructions and information for the Safety Integrated functions can be found in the associated Function Manual.

Options (continued)**K70****Fan power supply**

With option **K70**, the line voltage supply for the 400 V 3 AC auxiliary power supply system is tapped downstream of the circuit breaker and protected by a motor starter protector.

The voltages 230 V 1 AC and 24 V DC of the auxiliary power supply system are supplied externally on the plant side.

K73**SITOP power supply 24 V DC**

The 24 V DC supply for standard Booksize Cabinet Kits is tapped from the auxiliary power supply.

With option **K73**, the 24 V DC supply is provided by a dedicated SITOP power supply unit.

K76**Auxiliary voltage generation in the Line Connection Module**

Cabinet Modules require an auxiliary energy supply to function properly. This current demand must be included in the configuration and supplied from an external source. If an external supply is not possible, the required auxiliary voltages can be supplied by means of an Auxiliary Power Supply Module.

Alternatively, option **K76** can be selected. This provides for generation of auxiliary voltages in the Line Connection Module. This is particularly advisable for smaller device configurations.

With option **K76**, the following auxiliary voltages are provided:

	Air-cooled Cabinet Modules	Liquid-cooled Cabinet Modules
380 ... 480 V or 500 ... 690 V 2 AC	Possible tap for the following Line Connection Modules: <ul style="list-style-type: none"> Line Connection Module with rated current up to 800 A: 35 A Line Connection Module with rated current of 1000 to 1600 A: 50 A Line Connection Module 6SL3700-0LE42-0AA3: 50 A Line Connection Module with rated current of 2000 to 3200 A: 80 A 	–
230 V 1 AC	Possible tap for the Line Connection Modules: <ul style="list-style-type: none"> <800 A: approx. 4 A > 800 A: approx. 6 A 	Possible tap for Basic Line Connection Modules / Active Line Connection Modules 4 ... 10 A
24 V DC	Possible tap for the Line Connection Modules: <ul style="list-style-type: none"> <800 A: approx. 20 A > 800 A: approx. 40 A 	Possible tap for Basic Line Connection Modules / Active Line Connection Modules 5 ... 20 A

The supply for the auxiliary power supply system is connected at the auxiliary voltage module of the Line Connection Module.

K82**Terminal Module for controlling the Safe Torque Off and Safe Stop 1 safety functions**

The terminal module controls the Safety Integrated Basic Functions Safe Torque Off (STO) and Safe Stop 1 (SS1) (time-controlled) over a wide voltage range from 24 V to 240 V DC/AC (terminology as defined in IEC 61800-5-2).

The integrated safety functions, starting from the Safety Integrated (SI) input terminals of the components (Control Unit and Motor Module), satisfy the requirements of EN 61800-5-2, EN 60204-1, DIN EN ISO 13849-1 Category 3 for Performance Level (PL) d and IEC 61508 SIL 2.

With option **K82**, the requirements specified in EN 61800-5-2, EN 60204-1, DIN EN ISO 13849-1 Category 3 for Performance Level (PL) d and IEC 61508 SIL 2 are fulfilled.

The Safety Integrated functions using option **K82** are only available in conjunction with certified components and software versions.

The Safety Integrated functions of SINAMICS are generally certified by independent institutes. An up-to-date list of certified components is available on request from your local Siemens office.

K87**TM54F Terminal Module**

The TM54F Terminal Module is a terminal expansion module with safe digital inputs and outputs to control the Safety Integrated functions.

The TM54F is directly connected to a Control Unit via DRIVE-CLiQ. Each Control Unit can be assigned precisely to one TM54F.

Note:

It is not permissible to connect Motor Modules or Line Modules to a TM54F.

The TM54F provides 4 fail-safe digital outputs and 10 fail-safe digital inputs. A fail-safe digital output consists of one 24 V DC switching output, one output switching to ground and one digital input to check the switching state. A fail-safe digital input consists of two digital inputs.

[Description of the TM54F Terminal Module](#) → [SINAMICS S120 chassis format units](#) → [System components](#) → [Supplementary system components](#).

SINAMICS S120 Cabinet Modules

Options

Options (continued)

K88

SBA Safe Brake Adapter, 230 V AC

The Safe Brake Control (SBC) is a safety function, which is used in safety-relevant applications, for example in presses or rolling mills. In the no-current state, the brake acts on the drive motor using spring force. The brake is released when current flows in it (low active).

The Safe Brake Adapter is already installed in the cabinet unit in the factory. An infeed is connected to terminal -X12 on the Safe Brake Adapter for the power supply. For control, a connection is established between the Safe Brake Adapter and the Control Interface Module in the factory using a cable harness.

On the plant side, to control the brake, a connection must be established between terminal -X14 on the Safe Brake Adapter and the brake.

[Description of the SBA Safe Brake Adapter → SINAMICS S120 chassis format units → System components → Supplementary system components.](#)

K90

CU320-2 DP Control Unit (PROFIBUS)

Option **K90** assigns a CU320-2 DP Control Unit incl. CompactFlash card to the Line Modules and Motor Modules. This unit handles the communication and open-loop/closed-loop control functions. DRIVE-CLiQ is used to establish a connection to the various modules and where required, to additional I/O modules. A PROFIBUS interface is available as standard for the higher-level communication.

The computational performance required from the CU320-2 DP Control Unit increases with the number of connected Motor Modules and system components – as well as the dynamic performance demanded.

Without performance expansion, it is generally possible to operate two Motor Modules with one Line Module.

The full computational performance of the CU320-2 DP is only available on systems with performance expansion (option **K94**).

[Description of the CU320-2 Control Unit → SINAMICS S120 chassis format units → System components → Control Units.](#)

K94

Performance expansion for CU320-2 Control Unit

With option **K94**, the CU320-2 Control Unit (option **K90** or **K95**) is supplied with a CompactFlash card with performance expansion. This therefore provides the full computational performance of the CU320-2 Control Unit.

In addition to the firmware, the CompactFlash card also contains licensing codes that are required to enable firmware options, for example, the performance expansion and the Safety Integrated Extended Functions.

K95

CU320-2 PN Control Unit (PROFINET)

Option **K95** assigns a CU320-2 PN Control Unit, incl. CompactFlash card, to the Line Modules and Motor Modules. This unit handles the communication and open-loop/closed-loop control functions. DRIVE-CLiQ is used to establish a connection to the various modules and where required, to additional I/O modules. A PROFINET interface is available for the higher-level communication.

The computational performance required from the CU320-2 PN Control Unit increases with the number of connected Motor Modules and system components – as well as the dynamic performance demanded.

Without performance expansion, it is generally possible to operate two Motor Modules with one Line Module.

The full computational performance of the CU320-2 PN is only available on systems with performance expansion (option **K94**).

[Description of the CU320-2 Control Unit → SINAMICS S120 chassis format units → System components → Control Units.](#)

L00

Use in the first environment according to EN 61800-3, Category C2 (TN/TT supply systems with grounded neutral point)

With option **L00**, the Line Modules have a line filter as well as additional measures installed in the factory; this means that the Cabinet Modules can also comply with the limit values for use in the first environment (Category C2) according to EN 61800-3.

[Notes on the measures to be implemented by the customer are provided in the SINAMICS Low Voltage Engineering Manual.](#)

In order to achieve the full filter effect, the optional line filter must always be used in conjunction with a line reactor.

Note:

Option **L00** is not available for Line Modules in a parallel connection.

Options (continued)

L07**dv/dt filter compact plus Voltage Peak Limiter**

dv/dt filters compact plus VPL (**V**oltage **P**eak **L**imiter) limit the voltage rate-of-rise dv/dt to values of < 1600 V/μs and the typical voltage peaks to the following values in accordance with the limit value curve A according to IEC 60034-25: 2007:

- < 1150 V at $U_{line} < 575$ V
- < 1400 V at 660 V < $U_{line} < 690$ V

The dv/dt filter compact plus VPL functionally consists of two components that are supplied as a compact mechanical unit, the dv/dt reactor and the voltage limiting network (VPL), which limits voltage peaks and feeds back the energy to the DC link.

It is so compact that it can be completely integrated into the cabinet, even for high power ratings. An additional cabinet is not required.

By using a dv/dt filter compact plus VPL, standard motors with standard insulation and without insulated bearings can be used with supply voltages up to 690 V in converter operation.

The power losses stated in system component section System components → Motor-side components → dv/dt filters compact plus VPL can be used to determine the total losses for engineering purposes.

dv/dt filters compact plus VPL are designed for the following maximum motor cable lengths:

- Shielded cables 100 m (e.g. Protodur NYCWY)
- Unshielded cables 150 m (e.g. Protodur NYY)

For longer cable lengths (> 100 m shielded, > 150 m unshielded), the dv/dt filter plus VPL (option **L10**) should be used.

Notice:

- Operation with output frequencies < 10 Hz is permissible for max. 5 min.
- The maximum permissible output frequency is 150 Hz.

When using dv/dt filters, restrictions regarding permissible pulse frequencies must be observed.

Please also note the relevant information provided in the [SINAMICS Low Voltage Engineering Manual](#).

Note:

Option **L07** cannot be combined with the following options:

- **L08** (motor reactor)
- **L10** (dv/dt filter plus VPL)

L08**Motor reactor**

Motor reactors reduce the voltage load on the motor windings by reducing the voltage gradients at the motor terminals that occur during converter operation. At the same time, the capacitive charge/discharge currents that place an additional load at the Motor Module output when long motor cables are used are reduced.

Suitably dimensioned motor reactors or a series connection of several motor reactors make it possible to connect larger capacitances and thus allow the use of longer motor cables.

In the case of multi-motor drives, the use of motor reactors is recommended as a general principle.

The motor reactor is accommodated in the Cabinet Module. An additional 600-mm-wide cabinet located to the right of the Motor

Module is only required for the chassis format in frame sizes HX and JX.

[The power losses stated in the section System components → Motor-side components → Motor reactors can be used to determine the total losses for engineering purposes.](#)

Note:

The terminal lugs of the reactors are not nickel-plated.

For Motor Modules in chassis format, the maximum cable lengths when using motor reactors are 300 m (shielded) or 450 m (unshielded).

For Motor Modules in Booksize Cabinet Kit format, by using motor reactors (option **L08**) the maximum motor cable lengths, specified in the following table, can be reached:

Booksize Cabinet Kit	Rated output current of Motor Module	Maximum motor cable length when using motor reactors for Booksize Cabinet Kits					
		Shielded cable			Unshielded cable		
		Without reactor	With one reactor (option L08)	With two reactors in series (option L09)	Without reactor	With one reactor (option L08)	With two reactors in series (option L09)
6SL3720-...	A	m	m	m	m	m	m
1TE21-0AB3	9	50	135	–	75	200	–
1TE21-8AB3	18	70	160	320	100	240	480
1TE23-0AB3	30	100	190	375	150	280	560
1TE24-5AB3	45	100	200	400	150	300	600
1TE26-0AB3	60	100	200	400	150	300	600
1TE28-5AB3	85	100	200	400	150	300	600
1TE31-3AB3	132	100	200	400	150	300	600

SINAMICS S120 Cabinet Modules

Options

Options (continued)

L09

Two motor reactors in series

With option **L09** for Booksize Cabinet Kits, two motor reactors are used in series that can be located within the standard width of the Cabinet Kit.

The maximum permissible motor cable lengths when using option L09 are specified in the table under option **L08**.

Note:

The terminal lugs of the reactors are not nickel-plated.

L10

dv/dt filter plus Voltage Peak Limiter

A dv/dt filter plus VPL (Voltage Peak Limiter) limits the voltage rate-of-rise dv/dt to values $< 500 \text{ V}/\mu\text{s}$ and the typical voltage peaks to the following values in accordance with the limit value curve specified in IEC/TS 60034-17: 2006:

- $< 1000 \text{ V}$ at $U_{\text{line}} < 575 \text{ V}$
- $< 1250 \text{ V}$ at $660 \text{ V} < U_{\text{line}} < 690 \text{ V}$

The dv/dt filter plus VPL functionally consists of two components, the dv/dt reactor and the voltage limiting network (VPL), which limits voltage peaks and feeds the energy back to the DC link.

Option **L10** is installed in an additional cabinet with a width of 600 mm that is located on the right-hand side of the Motor Module.

By using a dv/dt filter plus VPL, standard motors with standard insulation and without insulated bearings can be used with supply voltages up to 690 V in converter operation.

dv/dt filters plus VPL are designed for the following maximum motor cable lengths:

- Shielded cable (e.g. Protodur NYCWY)
 - Motor Modules, frame sizes FX to HX: 300 m
 - Motor Modules, frame size JX: 150 m
- Unshielded cables (e.g. Protodur NYY)
 - Motor Modules, frame sizes FX to HX: 450 m
 - Motor Modules, frame size JX: 225 m

For cable lengths $< 100 \text{ m}$ shielded or $< 150 \text{ m}$ unshielded, the dv/dt filter compact plus VPL (option **L07**) can be used advantageously.

The power losses stated in the section System components → Motor-side components → dv/dt filters plus VPL can be used to determine the total losses for engineering purposes.

Notice:

- Operation with output frequencies $< 10 \text{ Hz}$ is permissible for max. 5 min.
- The maximum permissible output frequency is 150 Hz.

When using dv/dt filters, restrictions regarding permissible pulse frequencies must be observed.

Please also note the relevant information provided in the [SINAMICS Low Voltage Engineering Manual](#).

Note:

Parts of option **L10** do not have nickel-plated copper busbars. Option **L10** cannot be combined with the following options:

- **L07** (dv/dt filter compact plus VPL)
- **L08** (motor reactor)

L13

Main contactor (for supply currents $\leq 800 \text{ A}$)

Line Connection Modules for current ratings up to 800 A feature only a manually operated fuse switch disconnecter as standard. Option **L13** is needed if a switching element is also required for disconnecting the cabinet from the supply (needed for EMERGENCY OFF). The contactor is controlled by the closed-loop control in this case. Option **L13** can be ordered for Line Connection Modules together with Basic Line Modules (option **L43**). With Smart Line Modules and Active Line Modules, the contactor is included as standard.

L21

Surge suppression

In ungrounded IT systems, the line voltage is not permanently connected to the ground potential because of the missing ground connection of the supply network. Therefore, when a ground fault occurs during operation, a voltage against ground increased by a factor of 2 can occur. For this reason, it is recommended that a surge suppression against ground be installed for operation on IT systems. The surge suppression option includes the installation of line-side surge arresters and upstream fuses for each system phase. The signaling contacts for monitoring the surge arresters are connected in series and connected to a customer interface.

Note:

Option **L21** does not include the components required to install an insulation monitor for the IT system. An insulation monitor should always be ordered separately as option **L87** when the supplying IT system is not monitored at another position (e.g. at the transformer outgoing feeder). Only one insulation monitor can ever be used within the same electrically-connected network.

Option **L21** also does not include removal in the factory of the metal bracket that makes the connection to ground of the radio interference suppression filter installed as standard. The metal bracket should therefore be removed during the installation or commissioning of the converter if the device is to be operated on an ungrounded IT system.

L22

Delivery scope without line reactor

The air-cooled Basic Line Modules and Smart Line Modules as well as the liquid-cooled Basic Line Connection Modules are supplied with line reactors as standard; the reason for this is that frequently in practice the line configuration at the connection point of the drive line-up and/or the line supply short-circuit power is not known.

If the supply is connected through a separate transformer or if the line has a suitably low short-circuit power or if the standard integrated line reactor does not need to be supplied for other reasons, then this can be indicated by selecting option **L22**.

In the case of air-cooled Cabinet Modules, option **L22** can be selected for Line Connection Modules (rated current $< 2000 \text{ A}$) in conjunction with Basic Line Modules (option **L43**) and for Smart Line Modules. In the case of liquid-cooled Cabinet Modules, option **L22** can be selected for Basic Line Connection Modules.

For Basic Line Modules and Basic Line Connection Modules connected in parallel, a line reactor should always be used, i.e. option **L22** cannot be selected.

The power losses of each line reactor stated in section System components → Line-side components → Line reactors can be deducted from the total power loss for engineering purposes.

For additional information, please refer to the [SINAMICS Low Voltage Engineering Manual](#).

Options (continued)**L25****Withdrawable circuit breaker**

Line Connection Modules (air-cooled), Active Line Connection Modules and Basic Line Connection Modules (liquid-cooled) with an input current of > 800 A are equipped with fixed-mounted circuit breakers as standard. Where the customer requires a visible isolating distance, a withdrawable circuit breaker can be ordered as an option.

L34**Output-side circuit breaker**

Option **L34** can be used to disconnect the motor terminals from the Motor Module Chassis.

A rotating permanent-magnet synchronous motor generates a voltage at its motor terminals proportional to the speed. The motor terminal voltage is also available at the inverter output terminals as well as at the DC link and the components connected to it.

Option **L34** is available for disconnection in the case of a fault or if maintenance work is to be carried out.

Option **L34** is completely prewired and is accommodated in an additional cabinet, which is arranged at the right-hand side of the Motor Module (400 mm wide for frame sizes FX/GX, 600 mm wide for frame sizes HX/JX). It is controlled using a TM31 Terminal Module, which is included with this option. This means that the output switch is automatically controlled via the Motor Module.

Option **L34** cannot be combined with the following options:

- **L07** (dv/dt filter compact plus VPL)
- **L10** (dv/dt filter plus VPL)

L37**DC interface incl. pre-charging circuit of the relevant DC link capacitance**

If, for reasons relating to the process or availability, the Motor Module needs to be disconnected from the common DC link for an entire drive line-up or connected to it during operation, a manually operated isolating distance can be ordered as an option. With chassis format power units, this takes the form of switch disconnectors, and with Booksize Cabinet Kits, a contactor combination.

Option **L37** is installed on the busbar between the Motor Module and the main DC busbar. To ensure that the module can be connected to a pre-charged DC link, the option also includes a pre-charging circuit for the DC link capacitors of the relevant Motor Module.

The switching operation is performed externally. The operating levers can be locked using a padlock (padlock not included in scope of delivery). The degree of protection of the cabinets is not influenced.

The air guidance contains option **L37** and also option **M60** (additional touch protection).

Options **L61/L62** and **L64/L65** (braking units) cannot be ordered together with option **L37** for space reasons.

L40**Line filter monitoring**

With option **L40**, the filter in the Active Interface Module is monitored for effectiveness against harmonic effects on the system. The capacitance of the filter capacitors of the integrated filter is continuously calculated and compared with the installed nominal capacitance by measuring the current and voltage in the Active Interface Module. If the calculated capacity deviates by more than the set tolerance, an alarm is triggered.

L41**Current transformer upstream of main circuit breaker**

If additional current transformers are required for measuring or monitoring purposes, these can be ordered for (air-cooled) Line Connection Modules or (liquid-cooled) Active Line Connection Modules and Basic Line Connection Modules with option **L41**. The current transformers are installed upstream of the main circuit breaker in all three infeed phases.

The transformers have an accuracy class of 1.0. The secondary current is maximum 1 A.

The transformer measuring connections are routed to the terminal block in the Line Connection Module.

Note:

These current transformers are already included in options **P10** and **P11** (measuring instrument for the display of line values).

L42**Line Connection Module for Active Line Modules**

Order code **L42** is specified in the order to indicate that the Line Connection Module will be connected to an Active Line Module. The Line Connection Module is then adapted accordingly (pre-charging circuit, connection busbars, etc.). See also the information for the Line Connection Modules and the overview of options.

L43**Line Connection Module for Basic Line Modules**

Order code **L43** is specified in the order to indicate that the Line Connection Module will be connected to a Basic Line Module. The Line Connection Module is then adapted accordingly (line reactors, pre-charging circuit, connection busbars, etc.). See also the information for the Line Connection Modules and the overview of options.

L44**Line Connection Module for Smart Line Modules**

Order code **L44** is specified in the order to indicate that the Line Connection Module will be connected to a Smart Line Module. The Line Connection Module is then adapted accordingly (pre-charging circuit, connection busbars, etc.). See also the assignment table for the Line Connection Modules and the overview of options.

L45**EMERGENCY OFF pushbutton, installed in the cabinet door**

The EMERGENCY OFF pushbutton with protective collar is installed in the cabinet door of the Line Connection Module and its contacts are connected to a terminal block. From here, the EMERGENCY OFF pushbutton can be integrated into the plant-side EMERGENCY OFF chain.

SINAMICS S120 Cabinet Modules

Options

Options (continued)

L46

Grounding switch upstream of main circuit breaker

The grounding switch is upstream of the circuit breaker in the Line Connection Module and short-circuits the incoming supply system to ground. The grounding switch is manually engaged using a rotary operating mechanism to ensure isolation from the line supply when maintenance is being carried out. Measures must be taken at the plant to ensure that the grounding switch cannot be engaged when voltage is applied.

It is also essential to ensure that the supply system cannot be connected when the grounding switch is engaged.

The signals required for mutual interlocking are available on the terminal block.

L47

Grounding switch downstream of main circuit breaker

The grounding switch is installed downstream of the circuit breaker in the Line Connection Module and short-circuits the incoming supply system to ground downstream of the main circuit breaker. The grounding switch is manually engaged using a rotary operating mechanism to ensure isolation from the line supply when maintenance work is being carried out on the converter.

In this case, the grounding switch and the main circuit breaker for the Line Connection Module are interlocked with each other, which ensures that the grounding switch cannot be closed when the main circuit breaker is closed.

If the grounding switch is engaged, it is interconnected to ensure that the main circuit breaker cannot be closed.

L50

Cabinet lighting with service socket

With option **L50**, cabinet lighting is included with an additional service socket for a SCHUKO connector (connector type F) according to CEE 7/4. The power supply for the cabinet lighting and the service socket is external and must be fuse-protected for max. 10 A.

The cabinet lighting consists of an LED hand lamp with On/Off switch and with magnetic fasteners with an approx. 3 m long connecting cable. The lamp is factory-positioned in the cabinet door at a defined marking, and the connecting cable is wound on the associated mount.

L55

Cabinet anti-condensation heating

The anti-condensation heating is recommended at low ambient temperatures and high levels of humidity to prevent condensation. Depending on the cabinet width, a 100 W cabinet heater is installed for each Cabinet Module.

1 heating element for cabinet width up to 600 mm, 2 heating elements for cabinet width over 800 mm.

The power supply for the anti-condensation heating (110 V to 230 V AC, at terminal block -X240) must be provided externally and fused with max. 16 A.

L61, L62, L64, L65

Braking units

Braking units may be required for drives in which motors might operate in generator mode, but have no facility for feeding energy back into the supply system.

The braking unit comprises two components:

- A Braking Module that can be installed in the air discharge of the chassis format power units
- A braking resistor to be mounted externally (degree of protection IP20).

The braking unit functions as an autonomous unit, and does not require an external power supply. During the braking process, the kinetic energy is converted into heat in the externally mounted braking resistor.

A max. cable length of 100 m is permissible between the Braking Module and the braking resistor. This allows the braking resistor to be mounted externally so that heat losses can be dissipated outside the converter enclosure. The braking resistor is directly connected to the Braking Module.

For SINAMICS S120 Cabinet Modules the following braking modules are available, depending on the frame size:

Option	Can be used with frame sizes	Braking Module		
		Rated power P_{DB} kW	Braking power P_{20} kW	Peak power P_{15} kW
380 ... 480 V 3 AC, 660 ... 690 V 3 AC				
L61	FX	25	100	125
L62	GX, HX, JX	50	200	250
500 ... 600 V 3 AC				
L64	FX	25	100	125
L65	GX, HX, JX	50	200	250

P_{DB} : Rated power (continuous braking power)

P_{20} : 20 s power referred to a braking interval of 90 s

P_{15} : 15 s power referred to a braking interval of 90 s

If the braking units listed here do not provide adequate braking power, up to four braking units on a DC link busbar may be connected in parallel. Braking power can be shared among several Modules. In this case, a Braking Module is assigned to each braking resistor.

Note:

It is only possible to use a Braking Module, if a DC interface (option **L37**) has not been selected for the Motor Module.

When engineering the system, it should be ensured that the module in which the Braking Module is installed is switched on during braking so that the Braking Module is properly cooled. Failure to follow this instruction means that the Braking Module could overheat and shut down, the drive will no longer be able to operate in braking mode. In this case, the Braking Modules should preferably be located in the Line Modules.

Options (continued)

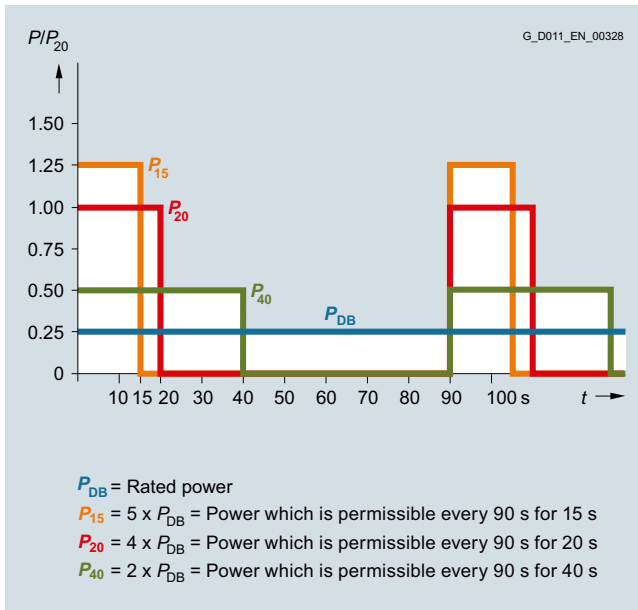

Load diagram for Braking Modules and braking resistors

Additional notes about possible duty cycles of the braking resistors and other engineering notes are included in the SINAMICS Low Voltage Engineering Manual.

L87**Insulation monitoring**

An insulation monitor must be used if the converter is connected to an ungrounded line supply. The device monitors the entire galvanically coupled circuit for insulation faults.

An alarm is output in the event of a fault.

Notice:

Only **one** insulation monitor can be used in each galvanically coupled network.

As there are different response strategies when a ground fault occurs in an ungrounded system, output relays of the insulation monitor are provided for integration in a plant-side control. It is also possible to integrate the outputs into the Cabinet Modules monitoring system on the plant side.

M06**Base 100 mm high, RAL 7022**

The additional cabinet base allows larger bending radii for cables (cable inlet from below) and enables them to be routed within the cabinet base.

The cabinet base is supplied in RAL 7022 as standard. A special paint finish is not available for the base. It is delivered completely assembled with the cabinet. The height of the operator panel changes accordingly.

M07**Cable marshaling space 200 mm high, RAL 7035**

The cable marshaling space is made of strong sheet steel and allows cables to be connected more flexibly (entry from below). It also allows routing of cables within the marshaling compartment. It is delivered completely assembled with the cabinet. The height of the operator panel changes accordingly.

Notice:

The cable compartment is painted as standard with RAL 7035. If a special color is requested for the cabinet (option **Y09**), the cable marshaling space is also painted in this color.

M21**Degree of protection IP21 (for air cooling only)**

Cabinet version in IP20, but with additional top cover or drip protection cover. This increases the cabinet height by 250 mm. For transport reasons, the top or drip protection covers are delivered separately and must be fitted on site.

Notice:

The top covers or canopies are painted in RAL 7035 as standard. If a special color is requested for the cabinet (option **Y09**), the roof sections or drip protection cover are also painted in this color.

Degree of protection IP21 is the standard version for liquid-cooled Cabinet Modules.

M23**Degree of protection IP23**

Cabinet Modules with degree of protection IP23 are supplied with additional plastic ventilation grilles and a filter medium in the air inlet and outlet. The filter medium must be maintained according to the local environmental conditions. The covers provided with option **M60** are also included in the scope of supply.

The air-cooled Cabinet Modules are additionally supplied with a roof section. This increases the cabinet height by 400 mm. For transport reasons, the roof sections are delivered separately and must be fitted on site.

Notice:

The roof sections are painted in RAL 7035 as standard. If a special color is requested for the cabinet (option **Y09**), the roof section is also painted in this color. The molded plastic parts (e.g. ventilation grilles) are in RAL 7035 and cannot be painted.

M26**Side panel mounted at the right**

For side-by-side installation of Cabinet Modules from left to right, cabinets can be ordered ready-prepared at the factory for assembly on-site. If option **M26** is ordered, the Cabinet Module is shipped with a side panel fitted on the right.

This side panel is essential for ensuring compliance with IP20 and higher degrees of protection.

SINAMICS S120 Cabinet Modules

Options

Options (continued)

M27

Side panel mounted to the left

For side-by-side installation of Cabinet Modules from right to left, cabinets can be ordered ready-prepared at the factory for assembly on-site. If option **M27** is ordered, the Cabinet Module is shipped with a side panel fitted on the left.

This side panel is essential for ensuring compliance with IP20 and higher degrees of protection.

M43

Degree of protection IP43

Cabinet Modules with degree of protection IP43 are supplied with additional plastic ventilation grilles and a filter medium in the air inlet and outlet. The filter medium must be maintained according to the local environmental conditions. The covers provided with option **M60** are also included in the scope of supply.

The air-cooled Cabinet Modules are additionally supplied with a roof section. This increases the cabinet height by 400 mm. For transport reasons, the roof sections are delivered separately and must be fitted on site.

Notice:

The roof sections are painted in RAL 7035 as standard. If a special color is requested for the cabinet (option **Y09**), the roof section is also painted in this color. The molded plastic parts (e.g. ventilation grilles) are in RAL 7035 and cannot be painted.

M51

Motor connection wired to customer terminal

Option **M51** is a meaningful add-on to option **M77** (version without component support plates or additional control components).

With option **M51**, the connection of the motor cable is wired to a customer terminal -X1 and thus makes the process of connecting motor cables easier.

Without option **M51**, the motor cable is connected directly to the Motor Module. In systems with one motor reactor or two series-connected motor reactors (option **L08/L09**), the motor cables are connected directly to the motor reactor.

M54

Degree of protection IP54 (for air cooling only)

Cabinet Modules with degree of protection IP54 are supplied with additional roof sections, plastic ventilation grilles, and a filter medium in the air inlet and outlet, which ensures compliance with degree of protection IP54. This increases the cabinet height by 400 mm. For transport reasons, the roof sections are delivered separately and must be fitted on site.

The filters must be maintained according to the local environmental conditions.

Notice:

- The roof sections are painted in RAL 7035 as standard. If a special color is requested for the cabinet (option **Y09**), the roof section is also painted in this color. The molded plastic parts (e.g. ventilation grilles) are in RAL 7035 and cannot be painted.
- For units with degree of protection IP54, it is important to observe the derating factor for output currents in relation to ambient temperature and installation altitude.

M55

Degree of protection IP55 (for liquid cooling only)

Cabinet Modules with degree of protection IP55 are supplied with closed doors and roof sheets (without additional roof section). Water jets from any angle are permitted. Because the cabinets are completely enclosed and there is no exchange of air with the environment, it is not necessary to clean a filter medium.

The derating data are provided in the derating characteristics for the liquid-cooled Cabinet Modules.

Almost all heat losses are dissipated into the cooling liquid.

M56

Reinforced mechanical design

This option includes a strengthened mechanical version of the cabinet and mechanical locking of the cabinet doors. To secure the converter to the floor, a welding frame (5 mm high) is supplied separately. This option is available for all degrees of protection.

Note:

Option **M56** cannot be combined with option **M70** (EMC shielding busbar).

M59

Closed cabinet doors, air inlet from below through floor opening

If the Cabinet Modules are erected on a false floor or duct which forms part of a forced ventilation system, the modules can be ordered with closed cabinet doors. To ensure an adequate air inlet cross-section, the units are shipped without the standard base plates. In this case, the customer must ensure that no dirt/dust or moisture can enter the Cabinet Module. Cables must not be routed in such a way that they impede the flow of air through the cabinet floor opening. If the area beneath the Cabinet Modules can be accessed, the customer must provide touch protection.

M60

Additional touch protection

The Cabinet Modules are designed in accordance with BGV A3 as standard. With option **M60**, additional covers (out of reach) at accessible operator control and switching elements, are provided in the area of the AC and DC busbars and in front of the power unit.

Option **M60** is already included in **M23**, **M43**, and **M54** for the following Cabinet Modules.

- Line Connection Modules
- Basic Line Modules
- Smart Line Modules
- Active Line Modules with Active Interface Modules
- Motor Modules chassis
- Central Braking Modules
- Auxiliary Supply Modules

Liquid-cooled Cabinet Modules incorporate additional touch protection as a standard feature - it does not have to be ordered with option **M60**.

M70

EMC shield bus

The EMC shield bus is used to connect shielded line and motor supply cables. The shields can be applied over a large surface area with the supplied EMC shield clips.

Options (continued)

M72**Quick-release couplings for water hoses (for liquid cooling only)**

With option **M72**, the ports for connecting the water hoses to the power modules and heat exchangers are fitted with quick-release couplings. The quick-release couplings ensure that no liquid escapes during uncoupling.

The use of quick-release couplings makes disassembly of the power modules and heat exchangers easier.

M77**Version without component support plates and without additional control components**

If electronic components (Control Unit, Terminal Modules, Sensor Modules) are not used in the Booksize Cabinet Kit, the mechanical component support plates are omitted with option **M77**, including the customer terminal blocks for connecting motor cables.

The motor cables are then connected directly to the Motor Module in booksize format.

When option **L08/L09** is used (motor reactor / 2 motor reactors in series), the motor cables are connected directly to the motor reactor.

The table below provides an overview of possible motor cable connection cross-sections for motor cables connected directly to a Motor Module in booksize format:

Booksize Cabinet Kit	Rated output current of Motor Module	Conductor cross-section
6SL3720-...	A	mm ²
1TE21-0AB3	9	1.5 ... 6
1TE21-8AB3	18	1.5 ... 6
1TE23-0AB3	30	1.5 ... 6
1TE24-5AB3	45	6 ... 50
1TE26-0AB3	60	6 ... 50
1TE28-5AB3	85	16 ... 120
1TE31-3AB3	132	25 ... 120

Note:

When combined with option **M51**, the motor connection is wired to a customer terminal.

M80 to M87**DC busbar system**

The correct DC busbar for the Cabinet Module must be ordered. This is fitted in the upper section of the Cabinet Modules and connects the Line Modules to the Motor Modules.

The busbar is dimensioned according to the load requirements and demand factor associated with operation of the individual drives, and according to the specific Cabinet Module layout. For this reason, the DC busbar is not supplied as standard, but must be ordered as an option.

When selecting busbars, it is important to ensure that the systems of adjacent Cabinet Modules are compatible with one another (refer to the table below and option selection matrix for the Cabinet Modules in question).

Where Cabinet Modules are ordered as a factory-assembled transport unit with option **Y11**, all busbars in the transport unit must be identical.

Order code	DC busbar system, rated current I_{rated}	Number	Dimensions mm	Compatible with
M80	1170	1	60 × 10	M83
M81	1500	1	80 × 10	M84 and M86
M82	1840	1	100 × 10	M85 and M87
M83	2150	2	60 × 10	M80
M84	2730	2	80 × 10	M81 and M86
M85	3320	2	100 × 10	M82 and M87
M86	3720	3	80 × 10	M81 and M84
M87	4480	3	100 × 10	M82 and M85

The DC busbars are nickel-plated as standard and are available in different designs for a variety of current-carrying capacities. The scope of delivery also includes the jumpers required to link the busbar systems of individual Cabinet Modules.

M88**DC busbar system for line-side Cabinet Modules (for liquid cooling only)**

Option **M88** is required if Motor Modules are to be installed to the left or if up to four Basic Line Connection Modules or Active Line Connection Modules are to be connected for a parallel connection.

For this purpose, DC busbars are built into the upper part on the left hand side in the line-side Cabinet Module of each Active Line Connection Module and Basic Line Connection Module.

The busbars are nickel plated as standard and are selected for different current carrying capacities as for the selected options **M80 to M87**.

SINAMICS S120 Cabinet Modules

Options

Options (continued)

M90

Crane transport assembly (top-mounted)

A top-mounted crane transport assembly can be ordered as an option for Cabinet Modules.

Depending on the width of the module, it consists of either transport eyebolts (width ≤ 800 mm) or transport rails (width > 800 mm).

When Cabinet Modules are ordered as factory-assembled transport units (option **Y11**), they are shipped with transport rails, i.e. option **M90** is automatically included in the scope of delivery of option **Y11** and does not need to be ordered separately.

M91

Marking of all control cable conductor ends (incl. customer-specific wiring)

When this option is selected, all control cables or conductor ends (including all customer-specific options) are labeled throughout the cabinet.

N52

DC link fuses

The Basic Line Modules (air-cooled), Active Line Connection Modules and Basic Line Connection Modules (liquid-cooled) come without DC link fuses as standard.

If fuses are required, they can be ordered with option **N52**. The fuses are mounted on the connecting rail to the DC busbar in the cabinet rather than in the power unit.

The use of DC link fuses is recommended when Basic Line Modules, Active Line Connection Modules, and Basic Line Connection Modules are connected in parallel.

The Motor Modules contain DC link fuses as standard.

P10

Measuring instrument for line values, mounted in the cabinet door

A measuring instrument with display, installed in the cabinet door of the Line Connection Module, for acquiring measured values of the power supply. In addition to these measured values, additional plant values (such as power and power factor, etc.) are calculated from the measured values using powerful, state-of-the-art microprocessors.

Current transformers (option **L41**) are already included in the scope of delivery.

P11

Measuring instrument for line values with PROFIBUS connection, mounted in the cabinet door

A measuring instrument with display, installed in the cabinet door of the Line Connection Module, for acquiring measured values of the power supply. In addition to these measured values, additional plant values (such as power and power factor, etc.) are calculated from the measured values using powerful, state-of-the-art microprocessors. The measuring instrument has a PROFIBUS interface that permits a data transfer rate of up to 12 Mbit/s.

Current transformers (option **L41**) are already included in the scope of delivery.

T58, T60, T80, T83, T85, T91

Rating plate data

The rating plate is provided in English/German as standard. A rating plate in another language combination can be selected by specifying the following option order codes.

Option	Rating plate language
T58	English/French
T60	English/Spanish
T80	English/Italian
T83	English/Portuguese (Brazil)
T85	English/Russian
T91	English/Chinese

W01

Partially redundant cooling unit with 2 pumps

The Heat Exchanger Module is equipped with a pump and a plate-type heat exchanger as standard. With option **W01**, two redundant pumps with two dirt traps are fitted: The pumps, which operate alternately, pump the hot coolant of the internal deionized water circuit into the plate-type heat exchanger and there it is cooled by the raw water of the plant-side cooling circuit.

System reliability is increased as a result of the alternating operation of the redundant pumps. In addition, the dirt traps can be cleaned independently and during operation.

W20

Raw water connection from the bottom

The raw water from the supply is fed into the Heat Exchanger Module from above as standard. With option **W20**, the Heat Exchanger Module has its port for the raw water underneath.

Y09

Special cabinet paint finish

The Cabinet Modules are delivered in RAL 7035 as standard. The special paint finish must be specified in plain text when ordering. Any RAL colors that are available as powdered coatings can be selected.

Notice:

If options such as cable marshaling space (option **M07**), top or drip protection covers (option **M21**) or roof sections (options **M23/M43/M54**) are ordered for the Cabinet Modules, they will also be supplied in the paint finish specified for the cabinet in the order. The molded plastic parts (e.g. ventilation grilles) are in RAL 7035 and cannot be painted.

Options (continued)**Y11****Factory assembly into transport units**

With this option, Cabinet Modules can be ordered as factory-assembled transport units with a maximum total width of up to 2400 mm. In this case, the relevant modules are shipped as interconnected units (both electrically and mechanically).

When DC busbars (options **M80** to **M87**) are selected, it must be ensured that identical busbars are installed within the transport unit and are compatible with all adjacent Cabinet Modules.

In the case of a transport unit order, all the Cabinet Modules to be included in the unit and their installation sequence from left to right must be specified in plain text according to the syntax below:

Plain text required to order	TE	1	-	1 ... 6
• Transport unit (TU)				
• Serial number of transport unit				
• Position of Cabinet Module within transport unit from left to right				

In the case of air-cooled Cabinet Modules, option **Y11** is recommended when creating units comprising Line Connection Modules with Line Modules because the required pre-charging circuits and connection busbars, for example, can be incorporated for certain versions. Please refer to the assignment tables for the Line Connection Modules.

With liquid-cooled Cabinet Modules, option **Y11** is especially recommended to reduce the number of connection elements used in the cooling circuit on the converter side. It results in lower resistance to flow and avoids leaks.

The transport unit is shipped with a crane transport rail, which means that option **M90** is not required.

Y31**One-line label for system identification, 40 × 80 mm**

Resopal labeling plates (white with black lettering) for identifying Cabinet Modules are available. The labels are stuck to the cabinet door.

Dimensions H × W: 40 × 80 mm

The text must be specified in plain text when ordering.

Field 1: Max. 9 characters, font size 10 mm.

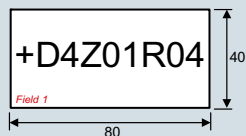
**Y32****Two-line label for system identification, 40 × 180 mm**

Resopal labeling plates (white with black lettering) for identifying Cabinet Modules are available. The labels are stuck to the cabinet door.

Dimensions H × W: 40 × 180 mm

The text must be specified in plain text when ordering.

Field 1: Max. 9 characters, font size 10 mm

Field 2: Max. 9 characters, font size 10 mm

Field 3: Max. 20 characters, font size 10 mm.

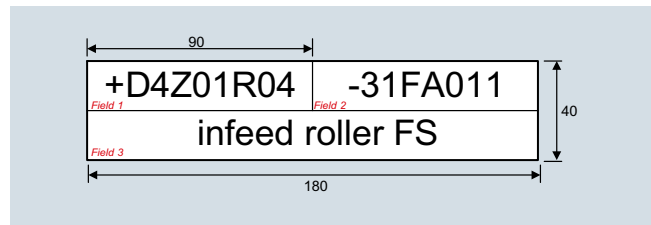
**Y33****Four-line label for system identification, 40 × 180 mm**

Resopal labeling plates (white with black lettering) for identifying Cabinet Modules are available. The labels are stuck to the cabinet door.

Dimensions H × W: 40 × 180 mm

The text must be specified in plain text when ordering.

Field 1: Max. 9 characters, font size 10 mm

Field 2: Max. 20 characters, font size 6 mm

Field 3: Max. 20 characters, font size 6 mm

Field 4: Max. 20 characters, font size 6 mm

Field 5: Max. 20 characters, font size 6 mm

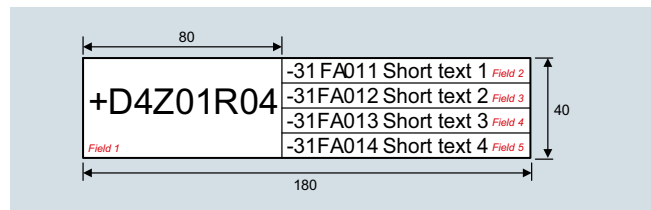

SINAMICS S120 Cabinet Modules

Supplementary system components

Overview

Mounting device for air-cooled power blocks



Power block mounting device for installing and removing the power blocks for the Basic Line Modules, Smart Line Modules, Active Line Modules and Motor Modules in chassis format.

The mounting device is a mounting aid. It is placed in front of the module and attached to the module. The telescopic rails allow the device to be adjusted to the installation height of the power blocks.

Once the mechanical and electrical connections have been released, the power block can be removed from the module.

The power block is guided and supported by the guide rails on the handling device.

Selection and ordering data

Description	Article No.
Mounting device for installing and removing power blocks	6SL3766-1FA00-0AA0

Overview

Just like the SINAMICS S120 chassis units, SINAMICS S120 Cabinet Modules form a modular drive system that consists of various intelligent Drive Objects such as Line Modules, Motor Modules, Control Units, Sensor Modules, etc.

As a consequence, SINAMICS S120 Cabinet Modules are supplied with documentation that only includes and describes the individual Cabinet Modules (circuit diagram, layout diagram, terminal diagram and additional Operating Instructions).

By selecting option **Y11**, individual Cabinet Modules are assembled at the factory as interconnected units for transport and are then supplied as such.

Detailed documentation showing features such as the signal connections between the individual Cabinet Modules that make up the order, is not included in the normal scope of delivery.

In this case, only a collection of the individual documents are shipped with the converter.

If the documentation is to include a complete representation of the equipment supplied, the equipment and documentation must be additionally processed. This can be ordered with the integration engineering.

Integration engineering includes the following:

- Checking the combinations and options ordered, in relation to the device configurations
- Defining how the individual drive objects are to be connected and coordinated, with the customer if required.
- Checking the performance of the ordered CompactFlash card
- Installing the required DRIVE-CLiQ cables within the transport units.
Cables between the transport units are connected at one end.
- Higher-level documentation of the scope of delivery (layout diagram, circuit diagram, terminal diagram, dimension drawing, spare parts list).
- Summary of the individual documents included in a shipment, in conjunction with a delivery address separate from the equipment
- Customer-specific system and location designations, coordinated with the customer

Note:

The order-specific integration engineering is especially recommended for liquid-cooled Cabinet Modules.

Selection and ordering data

The following engineering services can be ordered depending on the number of drives/axes included in an order:

Integration engineering	Article No.
For 1 drive (also parallel connection) including the associated Line Modules, Sensor Modules, Terminal Modules etc.	6SL3780-0AA00-0AA0
For up to 3 drives (also parallel connection) including the associated Line Modules, Sensor Modules, Terminal Modules etc.	6SL3780-0AC00-0AA0
For up to 5 drives (also parallel connection) including the associated Line Modules, Sensor Modules, Terminal Modules etc.	6SL3780-0AE00-0AA0
For up to 10 drives (also parallel connection) including the associated Line Modules, Sensor Modules, Terminal Modules etc.	6SL3780-0AJ00-0AA0

Engineering services for larger drive systems is also available on request.

Options

The table below lists the options available for order-specific integration engineering (for details, see [Description of the options](#)):

Available options	Order code
Customer documentation (circuit diagram, terminal diagram, layout diagram) in DXF format	D02
Preliminary version of customer documentation in PDF format	D14
Documentation in English / French	D58
Documentation in English / Spanish	D60
Documentation in English / Italian	D80
Documentation in English / Chinese	D91
Documentation in English / Russian	D94

When ordering the order-specific integration engineering, the required documentation options must always be ordered together with the order engineering (not to the individual Cabinet Modules).

Ordering the documentation options for the particular Cabinet Modules is only required if equipment is ordered without integration engineering.

Option selection matrix of the order-specific integration engineering

Certain options are mutually exclusive.

✓	Possible combination
–	Combination not possible

	D02	D14	D58	D60	D80	D91	D94
D02		✓	✓	✓	✓	✓	✓
D14	✓		✓	✓	✓	✓	✓
D58	✓	✓		–	–	–	–
D60	✓	✓	–		–	–	–
D80	✓	✓	–	–		–	–
D91	✓	✓	–	–	–		–
D94	✓	✓	–	–	–	–	

SINAMICS S120 Cabinet Modules

Customized solutions

More information

Customized solutions

In addition to the wide range of possibilities of configuring drives with the available modules and options to address specific plant and system requirements, for special applications we also offer customized applications to fully comply with the actual requirement.

These are based on the standard SINAMICS S120 Cabinet Modules and are supplied as completely wired units that are ready to be connected up.

Examples of applications such as these include:

- **SINAMICS S120 Cabinet Modules Application Marine Drive**

The range of requirements that drive systems have to meet aboard a ship is enormous – and highly varied. In addition to maximum efficiency and reliability, compactness is absolutely essential given the confined spaces. The systems used must also be low-maintenance, service-friendly, and in every way suitable for marine applications. Siemens' answer to these requirements is the SINAMICS S120 Cabinet Modules Application Marine Drive.

The innovative liquid-cooled drive system for all marine applications is based on the SINAMICS platform, which is a proven success worldwide. Its footprint has been optimized for use on board and it impresses with its flexibility and economic efficiency.

- **SINAMICS S120 Switch-Over Modules**

Where different motors have to run at different times on a common converter, SINAMICS S120 Switch-Over Modules are the ideal solution.

A Switch-Over Module switches the output of the Motor Module over to the motor that is required.

If, for example, processes powered by specific motors run at different times, or if the individual motor is only briefly used during the day, costs and space can be saved by using just one converter, supplemented with the corresponding Switch-Over Module.

Such an application involves, for instance instance, pump drives on tankers when various ship's compartments have to be emptied one after the other. Another application involves container cranes, if in addition to the drive for loading and unloading, also the drive for operating the boom must be fed from the converter.

- **SINAMICS S120 Motor Multi-Connection Modules**

SINAMICS S120 Motor Multi-Connection Modules are intended for applications in conjunction with group drives where a different number of multi-motor outputs are required. With Motor Multi-Connection Modules, Motor Modules are supplemented with a corresponding control system, as well as switching and protection devices. This configuration allows the associated motors with small power ratings (motor groups) to be operated from a common inverter with a high power rating.

The completely prewired and ready-to-connect cabinet units make commissioning quicker and easier. The transparent and flexible design allows changes and additions to be made at any time at low associated costs.

Simply contact us if you are interested or require these or any other applications.

Notes regarding the addresses of contact persons are provided in the appendix under "Contact partners for Industry Automation and Drive Technologies."



Cement mill



Ship docked in port with container crane



Oil rig

SINAMICS S150 Converter Cabinet Units



5/2	SINAMICS S150 converter cabinet units
5/2	Overview
5/2	Benefits
5/3	Application
5/3	Selection and ordering data
5/4	Design
5/6	Function
5/8	Technical specifications
5/15	Characteristic curves
5/18	Options

5/22	Description of the options
-------------	-----------------------------------

5/35	Line-side components
	Recommended fuses

5/36	Cable cross-sections and connections
-------------	---

5/38	Supplementary system components
-------------	--

5/38	Mounting device for power blocks
------	----------------------------------

SINAMICS S150 Converter Cabinet Units

SINAMICS S150 converter cabinet units

Overview



SINAMICS S150 converter cabinet units are particularly suitable for all variable-speed single-axis drives with high performance requirements, i.e. drives with:

- High dynamic requirements
- Frequent braking cycles and high braking energy levels
- Four-quadrant operation

SINAMICS S150 offers high-performance speed control with excellent accuracy and a high dynamic response.

The following voltages and power ratings are available:

Line voltage	Type rating
380 ... 480 V 3 AC	110 ... 800 kW
500 ... 690 V 3 AC	75 ... 1200 kW

Degrees of protection are IP20 (standard) and optionally IP21, IP23, IP43 and IP54.

Line and motor-side components as well as additional monitoring devices can be installed in the converter cabinet units.

A wide range of electrical and mechanical components enable the drive system to be optimized individually to suit customer requirements.

Benefits

The self-commutating, pulsed infeed/regenerative unit uses IGBT technology and is equipped with a Clean Power Filter. This combination guarantees extremely line-friendly behavior which is characterized by the following:

- Negligible line harmonics as a result of the innovative Clean Power Filter ($<< 1\%$)
- The stringent limit values of the standard IEEE 519-1992 are fully complied with.
- Regenerative feedback (four-quadrant operation)
- Tolerant to fluctuations in the line voltage
- Operation on weak line supplies
- Reactive power compensation is possible (inductive or capacitive)
- High drive dynamic performance

In addition, factors have been considered to ensure easy handling of the drive from the planning and design phase through to operation. These factors include:

- Compact, modular design with an optimum degree of service friendliness
- Straightforward configuring and commissioning thanks to assistance provided by the SIZER for Siemens Drives and STARTER tools
- Simple installation, as it is ready to be connected up
- Fast, menu-prompted commissioning with no complex parameterization
- Clear and convenient drive monitoring/diagnostics, commissioning and operation via a user-friendly graphical operator panel with measured values displayed in plain text or in a quasi-analog bar display.
- SINAMICS as an integral part of Totally Integrated Automation (TIA). The TIA concept offers an optimized range of products for automation and drive technology. This concept is characterized by configuration, communication, and data management that are consistent throughout the product range. SINAMICS is fully integrated in the TIA concept. Separate S7/PCS7 blocks and faceplates for WinCC are available.
- Integration in SIMATIC H systems via a Y link
- SINAMICS Drive Control Chart (SINAMICS DCC) SINAMICS DCC is an additional tool for the easy configuration of process-oriented functions for SINAMICS. The block library encompasses a large selection of closed-loop, arithmetic and logic blocks, as well as a more comprehensive range of open-loop and closed-loop control functions. The user-friendly DCC editor enables easy graphics-based configuration, allows control loop structures to be clearly represented and provides a high degree of reusability of charts that have already been created. SINAMICS DCC is an add-on to the STARTER commissioning tool.

Application

SINAMICS S150 is especially suitable for use in all applications that place the highest demands on process operations with dynamic, reproducible processes. These include, for example:

- Test stands
- Centrifuges
- Elevators and cranes
- Cross cutters and shears
- Conveyor belts with a high power demand and energy recovery
- Presses
- Cable winches

Selection and ordering data

Type rating at 400 V or 690 V kW	Rated output current I_{rated} A	SINAMICS S150 converter cabinet unit Article No.
Line voltage 380 ... 480 V 3 AC		
110	210	6SL3710-7LE32-1AA3
132	260	6SL3710-7LE32-6AA3
160	310	6SL3710-7LE33-1AA3
200	380	6SL3710-7LE33-8AA3
250	490	6SL3710-7LE35-0AA3
315	605	6SL3710-7LE36-1AA3
400	745	6SL3710-7LE37-5AA3
450	840	6SL3710-7LE38-4AA3
560	985	6SL3710-7LE41-0AA3
710	1260	6SL3710-7LE41-2AA3
800	1405	6SL3710-7LE41-4AA3
Line voltage 500 ... 690 V 3 AC		
75	85	6SL3710-7LG28-5AA3
90	100	6SL3710-7LG31-0AA3
110	120	6SL3710-7LG31-2AA3
132	150	6SL3710-7LG31-5AA3
160	175	6SL3710-7LG31-8AA3
200	215	6SL3710-7LG32-2AA3
250	260	6SL3710-7LG32-6AA3
315	330	6SL3710-7LG33-3AA3
400	410	6SL3710-7LG34-1AA3
450	465	6SL3710-7LG34-7AA3
560	575	6SL3710-7LG35-8AA3
710	735	6SL3710-7LG37-4AA3
800	810	6SL3710-7LG38-1AA3
900	910	6SL3710-7LG38-8AA3
1000	1025	6SL3710-7LG41-0AA3
1200	1270	6SL3710-7LG41-3AA3

SINAMICS S150 Converter Cabinet Units

Converter cabinet units

Design

The SINAMICS S150 converter cabinet units are characterized by their compact, modular and service-friendly design.

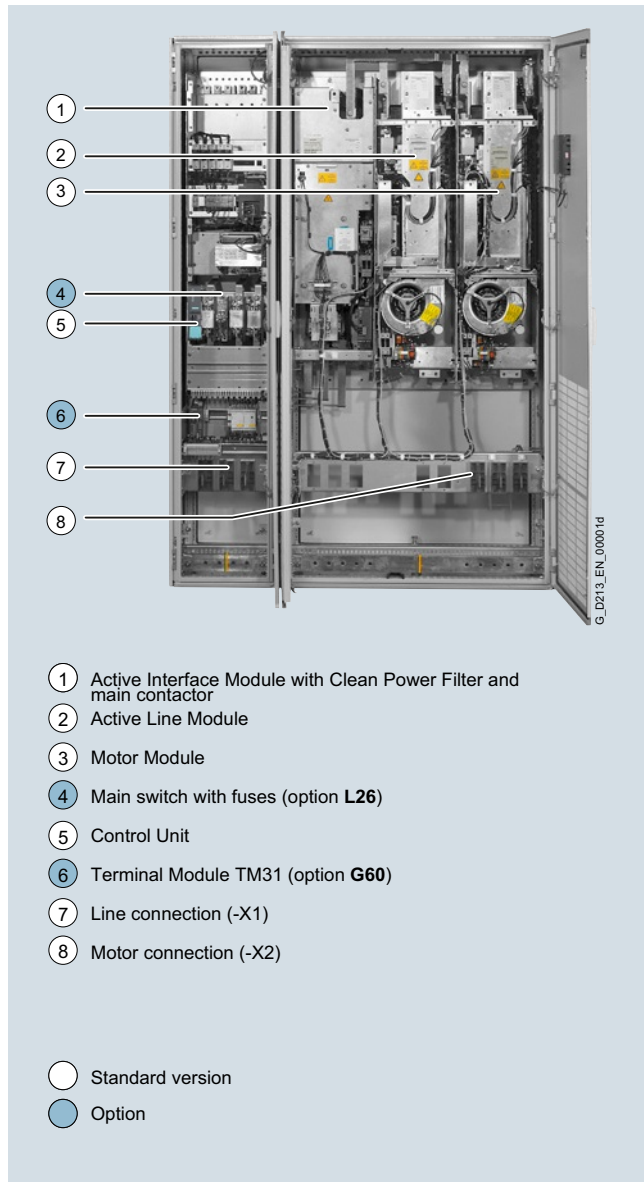

Design example of a SINAMICS S150 converter cabinet unit

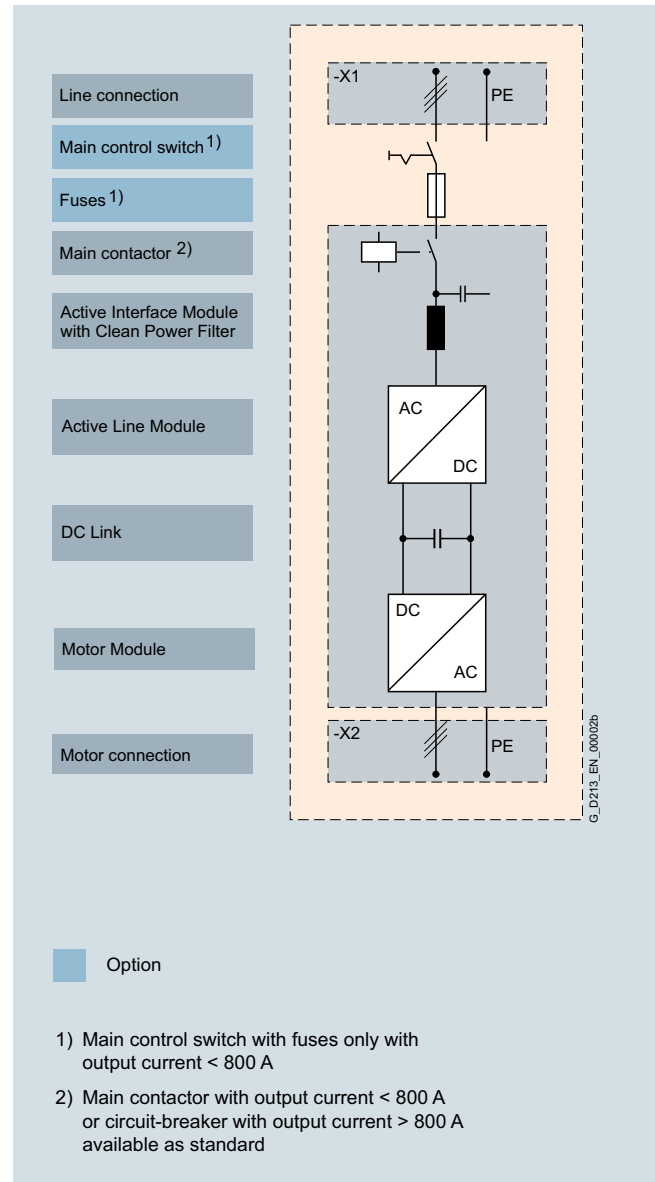

Basic design of a SINAMICS S150 converter cabinet unit with a number of version-specific options

Design (continued)**Coated modules**

The following devices are equipped as standard with coated modules:

- Chassis format units
- Control Units
- Sensor Modules
- Terminal Modules
- Advanced Operator Panel (AOP30)

The coating on the modules protects the sensitive SMD components against corrosive gases, chemically active dust and moisture.

Nickel-plated busbars

All of the copper busbars used in the converter cabinets are nickel-plated in order to achieve the best possible immunity to environmental effects. Further, it is possible to eliminate having to clean the contacts at the customer connections, which is required for bare copper connections.

Note:

With some options, parts of the copper busbars cannot be nickel-plated for technical reasons.

Degrees of protection

The EN 60529 standard covers the protection of electrical equipment by means of housings, covers or equivalent, and includes:

- Protection of persons against accidental contact with live or moving parts within the housing and protection of the equipment against the ingress of solid foreign bodies (touch protection and protection against ingress of solid foreign bodies)
- Protection of the equipment against the ingress of water (water protection)
- Abbreviations for the internationally agreed degrees of protection

The degrees of protection are specified by abbreviations comprising the code letters IP and two digits.

Degree of protection	First digit (Touch protection and protection against foreign bodies)	Second digit (Protection of equipment against the ingress of water)
IP20 (Standard)	Protected against solid foreign bodies with a diameter ≥ 12.5 mm	No water protection
IP21 (Option M21)	Protected against solid foreign bodies with a diameter ≥ 12.5 mm	Protected against drip water Vertically falling water drops must not have any harmful effects.
IP23 (Option M23)	Protected against solid foreign bodies with a diameter ≥ 12.5 mm	Protected against spray water Water sprayed on both sides of the vertical at an angle of up to 60° shall not have a harmful effect.
IP43 (Option M43)	Protected against solid foreign bodies diameter ≥ 1 mm	Protected against spray water Water sprayed on both sides of the vertical at an angle of up to 60° shall not have a harmful effect.
IP54 (Option M54)	Dust protected Ingress of dust is not totally prevented, but dust must not be allowed to enter in such quantities that the functioning or safety of the equipment is impaired.	Protected against splash water Water splashing onto the housing from any direction must not have any harmful effects.

SINAMICS S150 Converter Cabinet Units

Converter cabinet units

Function

AOP30 Advanced Operator Panel

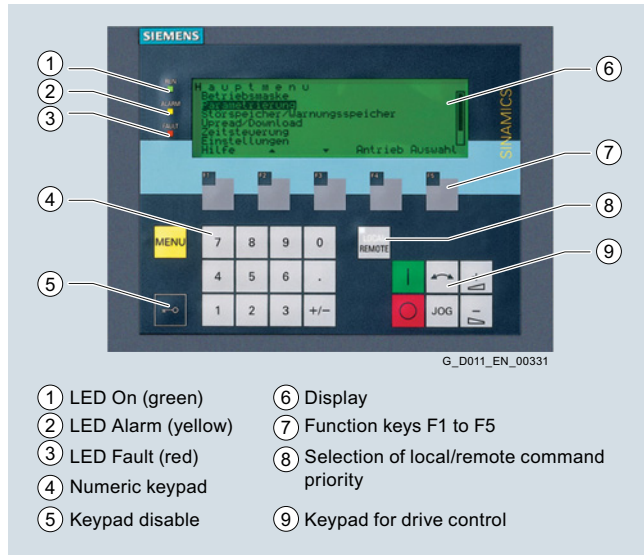

An Advanced Operator Panel (AOP30) is installed in the cabinet door of the converter for operation, monitoring and commissioning tasks.

The user is guided by interactive menus through the drive commissioning screens. When the drive is commissioned for the first time, only 6 motor parameters (which can be found on the motor rating plate) have to be entered on the AOP30. The closed-loop control is then optimized automatically to adapt the converter to the motor.

The AOP30's two-stage safety concept prevents unintentional or unauthorized changes to settings. Operation of the drive from the operator panel can be disabled by the keyboard lock and so that only parameter values and process variables can be displayed on the operator panel. The OFF key is factory-set to "active", but can be deactivated by the customer. A password can be used to prevent the unauthorized changing of converter parameters.

German, English, French, Italian, Spanish and Chinese are stored on the CU320-2 Control Unit CompactFlash card as operator panel languages. The desired language must be downloaded to the AOP30 prior to commissioning. In addition to these standard operator panel languages, Russian can also be retro-installed. Further languages are available on request.

Examples of plain-text displays during various phases of operation are shown below.

The **first commissioning** is performed via the operator panel.

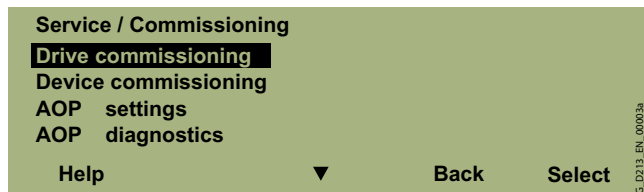

Only 6 motor parameters have to be entered: Power, speed, current, $\cos \varphi$, voltage and frequency of the motor.

This information can be found on the motor rating plate, and must be entered in the screens on the display by following a short, menu-assisted procedure. The motor cooling method must also be specified.

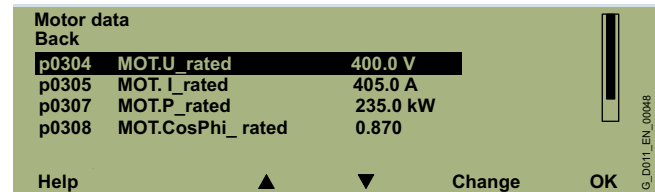

The next screen contains the parameter values that are used to automatically optimize the control.

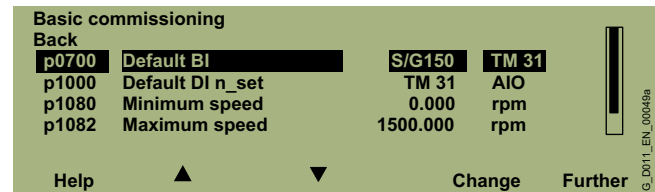

During operation, the display shows current data, such as set-points and actual values as absolute values or it is possible to parameterize up to 3 process variables as a quasi-analog bar display.

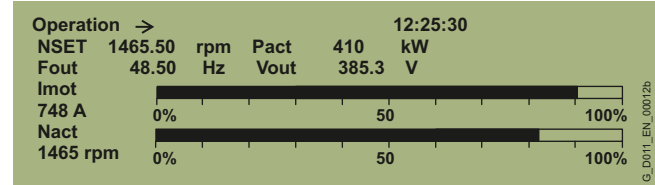
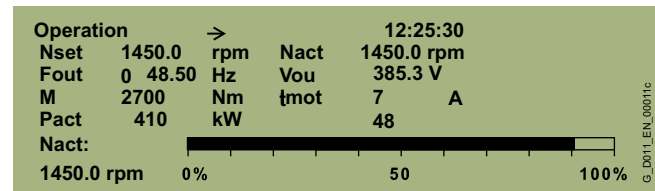

Any **alarms** that occur are signaled by flashing of the yellow ALARM LED, **faults** by the red FAULT LED, which is then lit. There is also an indication of the cause displayed in plain text on the display's status line (with counter/remedial measures).

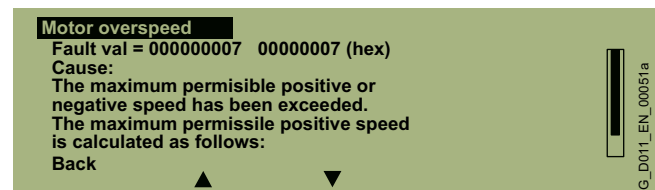
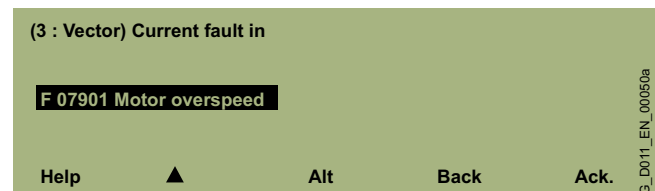

Function (continued)**Communication with higher-level controller and customer terminal block**

A PROFIBUS or PROFINET interface on the Control Unit CU320-2 is provided as standard as the customer control interface.

This interface can be used to connect the system to the higher-level controller using analog and digital signals, or to connect additional units.

The inputs and outputs available as standard can be optionally expanded by up to two Terminal Modules TM31 (refer to the description of options, option **G60** or **G61**). To simplify configuration and commissioning of the drive, the TM31 Terminal Module can be preset to a variety of factory settings.

For additional information, please refer to the SINAMICS Low Voltage Engineering Manual.

Open-loop and closed-loop control functions

SINAMICS S150 has a high-dynamic vector control with speed and current control – with and without speed actual value feedback.

Software and protective functions

The software functions available as standard are described below.

Software and protective functions	Description
Setpoint input	The setpoint can be specified both internally and externally; internally as a fixed setpoint, motorized potentiometer setpoint or jog setpoint, externally via the communications interface or an analog input. The internal fixed setpoint and the motorized potentiometer setpoint can be switched or adjusted via control commands from any interface.
Motor identification	The automatic motor identification function makes commissioning faster and easier and optimizes closed-loop control of the drive.
Ramp-function generator	A user-friendly ramp-function generator with separately adjustable ramp-up and ramp-down times, together with adjustable rounding times in the lower and upper speed ranges, allows the drive to be smoothly accelerated and braked. This results in a good speed control response and plays its role in reducing the stress on the mechanical system. The down ramps can be parameterized separately for quick stop.
$V_{dc\ max}$ controller	The $V_{dc\ max}$ controller automatically prevents overvoltages in the DC link, if the set down ramp is too short, for example. This may also extend the set ramp-down time.
Kinetic buffering (KIP)	For brief line supply failures, the kinetic energy of the rotating drive is used to buffer the DC link and therefore prevents fault trips. The drive converter remains operational as long as the drive can provide regenerative energy as a result of its motion and the DC link voltage does not drop below the shutdown threshold. When the line supply recovers within this time, the drive is again bumplessly accelerated up to its setpoint speed.
Automatic restart	The automatic restart switches the drive on again when the power is restored after a power failure, and ramps up to the current speed setpoint.
Flying restart	The flying restart function allows the converter to be switched to a motor that is still turning. With the voltage sensing capability provided by the optional VSM10, the flying restart time for large induction motors can be significantly reduced because the motor does not need to be de-magnetized.
Technology controller	The technology controller function module allows simple control functions to be implemented, e.g. level control or volumetric flow control and complex tension controls. The existing D component can act both on the system deviation well as on the actual value (factory setting). The P, I, and D components are set separately.
Free function blocks	Using the freely programmable function blocks, it is easy to implement logic and arithmetic functions for controlling the SINAMICS drive. The blocks can be programmed at the operator panel or the STARTER commissioning tool.
SINAMICS Drive Control Chart (SINAMICS DCC)	SINAMICS DCC is an additional tool for the easy configuration of technological functions for SINAMICS. The block library contains a large selection of control, arithmetic and logic blocks as well as extensive open-loop and closed-loop control functions. The user-friendly DCC editor enables easy graphics-based configuration, allows control loop structures to be clearly represented and provides a high degree of reusability of charts that have already been created. SINAMICS DCC is an add-on to the STARTER commissioning tool (→ Tools and Engineering).
\dot{I}^2t sensing for motor protection	A motor model stored in the converter software calculates the motor temperature based on the current speed and load. More exact measurement of the temperature, which also takes into account the influence of the ambient temperature, is possible by means of direct temperature measurement using KTY84 sensors in the motor winding.
Motor temperature evaluation	Motor protection by evaluating a KTY84, PTC or Pt100 temperature sensor. When a KTY84 temperature sensor is connected, the limit values can be set for alarm or shutdown. When a PTC thermistor is connected, the system reaction to triggering of the thermistor (alarm or trip) can be defined.
Motor blocking protection	A blocked motor is detected and protected against thermal overloading by a fault trip.
Brake control	"Simple brake control" for control of holding brakes: The holding brake is used to secure drives against unwanted motion when deactivated. "Extended brake control" function module for complex brake control, e.g. for motor holding brakes and operational brakes: When braking with a feedback signal, the brake control reacts to the feedback signal contacts of the brake.
Write protection	Write protection to prevent unintentional changing of the setting parameters (without password function).
Know-how protection	Know-how protection for encrypting stored data, e.g. to protect configuration know-how, and to protect against changes and duplication (with password function).
Web server	The integrated web server provides information about the drive unit via its web pages. The web server is accessed using an Internet browser via unsecured (http) or secured transmission (https).

SINAMICS S150 Converter Cabinet Units

Converter cabinet units

Function (continued)

Power unit protection

Power unit protection	Description
Ground fault monitoring at the output	A ground fault at the output is detected by a total current monitor and results in shutdown in grounded systems.
Electronic short-circuit protection at the output	A short-circuit at the output (e.g. at the converter output terminals, in the motor cable or in the motor terminal box) is detected and the converter shuts down with a "fault".
Thermal overload protection	An alarm is issued first when the overtemperature threshold responds. If the temperature continues to rise, the unit either shuts down or independently adjusts the pulse frequency or output current so that thermal load is reduced. Once the cause of the fault has been eliminated (e.g. cooling has been improved), the original operating values are automatically resumed.

Technical specifications

The most important directives and standards are listed below. These are used as basis for the SINAMICS S150 converter cabinet units and they must be carefully observed to achieve an EMC-compliant configuration that is safe both functionally and in operation.

European directives

2006/95/EC	Low Voltage Directive: Directive of the European Parliament and Council of December 12, 2006, on the approximation of the laws of the member states relating to electrical equipment designed for use within certain voltage limits
2004/108/EC	EMC Directive: Directive of the European Parliament and Council of December 15, 2004, which repeals directive 89/336/EEC, on the approximation of laws of the member states relating to electromagnetic compatibility
2006/42/EC	Machinery Directive: Directive of the European Parliament and Council of May 17, 2006, on machinery and amending Directive 95/16/EC (recast).

European standards

EN ISO 3744	Acoustics – Determination of the sound power level and sound energy level for noise sources that result from sound pressure measurements – envelope surface procedure of the accuracy class 2 for a largely free sound field over a reflecting plane
EN ISO 13849-1	Safety of machinery – safety-related parts of control systems; Part 1: General design guidelines (ISO 13849-1: 2006)
EN 60146-1-1	Semiconductor converters – General requirements and line-commutated converters Part 1-1: Specification of basic requirements
EN 60204-1	Safety of machinery – Electrical equipment of machines; Part 1: General requirements
EN 60529	Degrees of protection provided by enclosures (IP code)
EN 61508-1	Functional safety of electrical/electronic/programmable electronic safety-related systems Part 1: General requirements
EN 61800-2	Adjustable speed electrical power drive systems Part 2: General requirements; rating specifications for low voltage adjustable frequency AC power drive systems
EN 61800-3	Adjustable speed electrical power drive systems Part 3: EMC requirements and specific test methods
EN 61800-5-1	Adjustable speed electrical power drive systems Part 5: Safety requirements Main section 1: Electrical and thermal requirements
EN 61800-5-2	Adjustable speed electrical power drive systems Part 5-2: Safety requirements – Functional safety (IEC 61800-5-2: 2007)

Technical specifications (continued)

General technical specifications

Electrical specifications			
Line voltages	380 ... 480 V 3 AC, ±10% (-15% <1 min) 500 ... 690 V 3 AC, ±10% (-15% <1 min)		
Line supply types	Grounded TN/TT systems and non-grounded IT systems		
Line frequency	47 ... 63 Hz		
Output frequency ¹⁾	0 ... 550 Hz		
Line power factor	Adjustable (factory-set to $\cos \varphi = 1$)		
Efficiency	>96%		
Overvoltage category	III to EN 61800-5-1		
Control method	Vector control with and without encoder or V/f control		
Fixed speeds	15 fixed speeds plus 1 minimum speed, parameterizable (in the default setting, 3 fixed setpoints plus 1 minimum speed are selectable using terminal block/PROFIBUS/PROFINET)		
Skippable speed ranges	4, parameterizable		
Setpoint resolution	0.001 rpm digital (14 bits + sign) 12 bits analog		
Braking operation	Four-quadrant operation is possible as standard (optional via a braking unit if braking is required when power fails)		
Mechanical specifications			
Degree of protection	IP20 (higher degrees of protection up to IP54 optional)		
Protection class	I acc. to EN 61800-5-1		
Touch protection	EN 50274 / BGV A3 when used for the intended purpose		
Cabinet system	Rittal TS8, doors with double-bit key, three-section base plates for cable entry		
Paint finish	RAL 7035 (indoor requirements)		
Cooling method	Forced air cooling AF according to EN 60146		
Ambient conditions	Storage ²⁾	Transport ²⁾	Operation
Ambient temperature	-25 ... +55 °C	-25 ... +70 °C from <u>-40 °C</u> for 24 hours	<u>0 ... 40 °C</u> to +50 °C, see derating data
Relative humidity (condensation not permissible)	<u>5 ... 95%</u> Class 1K4 acc. to IEC 60721-3-1	5 ... 95% at 40 °C Class 2K3 acc. to IEC 60721-3-2	5 ... <u>95%</u> Class 3K3 acc. to IEC 60721-3-3
Environmental class/ harmful chemical substances	Class 1C2 acc. to IEC 60721-3-1	Class 2C2 acc. to IEC 60721-3-2	Class 3C2 acc. to IEC 60721-3-3
Organic/biological influences	Class 1B1 acc. to IEC 60721-3-1	Class 2B1 acc. to IEC 60721-3-2	Class 3B1 acc. to IEC 60721-3-3
Degree of pollution	2 acc. to EN 61800-5-1		
Installation altitude	Up to 2000 m above sea level without derating; > 2000 m see derating data		
Mechanical stability	Storage ²⁾	Transport ²⁾	Operation
Vibratory load	Class 1M2 acc. to IEC 60721-3-1	Class 2M2 acc. to IEC 60721-3-2	–
• Deflection	1.5 mm at <u>5 ... 9 Hz</u> ³⁾	3.1 mm at <u>5 ... 9 Hz</u> ³⁾	0.075 mm at 10 ... 58 Hz
• Acceleration	5 m/s ² at > <u>9 ... 200 Hz</u>	10 m/s ² at <u>9 ... 200 Hz</u>	9.8 m/s ² at 58 ... 200 Hz
Shock load	Class 1M2 acc. to IEC 60721-3-1	Class 2M2 acc. to IEC 60721-3-2	Class 3M4 acc. to IEC 60721-3-3
• Acceleration	40 m/s ² at 22 ms	100 m/s ² at 11 ms	100 m/s ² at 11 ms
Compliance with standards			
Conformances/approvals, according to	CE (EMC Directive No. 2004/108/EC and Low Voltage Directive No. 2006/95/EC and Machinery Directive No. 2006/42/EC for functional safety)		
Radio interference suppression	SINAMICS drive converter systems are not designed for connection to the public grid (first environment). Radio interference suppression is compliant with the EMC product standard for variable-speed drives EN 61800-3, "Second environment" (industrial networks). EMC disturbances can occur when connected to the public power networks. However, if additional measures are taken (e.g. line filter), it can also be operated in the "first environment".		

Deviations from the specified classes are underlined.

¹⁾ Please note:

- The correlation between the maximum output frequency, pulse frequency and current derating. Higher output frequencies on request.
- The correlation between the maximum output frequency and permissible output current (current derating).

[Information is provided in the SINAMICS Low Voltage Configuration Manual.](#)

²⁾ In transport packaging.

SINAMICS S150 Converter Cabinet Units

Converter cabinet units

Technical specifications (continued)

Line voltage 380 ... 480 V 3 AC		SINAMICS S150 Converter Cabinet Units					
		6SL3710-7LE32-1AA3	6SL3710-7LE32-6AA3	6SL3710-7LE33-1AA3	6SL3710-7LE33-8AA3	6SL3710-7LE35-0AA3	6SL3710-7LE36-1AA3
Type rating							
• At I_L (50 Hz 400 V) ¹⁾	kW	110	132	160	200	250	315
• At I_H (50 Hz 400 V) ¹⁾	kW	90	110	132	160	200	250
• At I_L (60 Hz 460 V) ²⁾	hp	150	200	250	300	400	500
• At I_H (60 Hz 460 V) ²⁾	hp	150	200	200	250	350	350
Output current							
• Rated current $I_{rated O}$	A	210	260	310	380	490	605
• Base-load current I_L ³⁾	A	205	250	302	370	477	590
• Base-load current I_H ⁴⁾	A	178	233	277	340	438	460
• Maximum current $I_{max O}$	A	307	375	453	555	715	885
Infeed/regenerative feedback current							
• Rated input current $I_{rated I}$	A	197	242	286	349	447	549
• Maximum input current $I_{max I}$	A	315	390	570	570	735	907
Current demand, max. ⁵⁾							
• 24 V DC aux. power supply	A	Internal	Internal	Internal	Internal	Internal	Internal
Pulse frequency ⁶⁾							
• Rated frequency	kHz	2	2	2	2	2	1.25
• Pulse frequency, max.							
- Without current derating	kHz	2	2	2	2	2	1.25
- With current derating	kHz	8	8	8	8	8	7.5
Power loss, max. ⁷⁾							
• At 50 Hz 400 V	kW	6.31	7.55	10.01	10.72	13.13	17.69
• At 60 Hz 460 V	kW	6.49	7.85	10.45	11.15	13.65	18.55
Cooling air requirement		m ³ /s	0.58	0.7	1.19	1.19	1.96
Sound pressure level L_{pA} (1 m) at 50/60 Hz		dB	71/73	71/73	72/74	72/74	77/79
Cable length, max.							
• Shielded	m	300	300	300	300	300	300
• Unshielded	m	450	450	450	450	450	450
Degree of protection			IP20	IP20	IP20	IP20	IP20
Dimensions							
• Width	mm	1400	1400	1600	1800	1800	2200
• Height	mm	2000	2000	2000	2000	2000	2000
• Depth	mm	600	600	600	600	600	600
Weight (without options), approx.		kg	708	708	892	980	1716
Short-circuit current rating according to IEC ⁸⁾		kA	65	65	65	65	65
Minimum short-circuit current ⁹⁾		A	3000	3000	4500	4500	8000
Frame sizes							
• Active Interface Module		FI	FI	GI	GI	GI	HI
• Active Line Module		FX	FX	GX	GX	GX	HX
• Motor Module		FX	FX	GX	GX	GX	HX

Note:

The power data in hp units is based on the NEC/CEC standards for the North American market. Information about line supply connections, motor connections and cabinet grounding can be found under **Cable cross-sections and connections**.

¹⁾ Rated output of a typical 6-pole standard induction motor based on I_L or I_H for 400 V 3 AC 50 Hz.

²⁾ Rated output of a typical 6-pole standard induction motor based on I_L or I_H for 460 V 3 AC 60 Hz.

³⁾ The base-load current I_L is based on a load cycle of 110% for 60 s or 150% for 10 s with a load cycle duration of 300 s.

⁴⁾ The base-load current I_H is based on a duty cycle of 150% for 60 s or 160% for 10 s with a duty cycle duration of 300 s.

⁵⁾ If the drive closed-loop control is still to remain active when the line supply fails, the equipment must be provided with an external 24 V DC supply.

⁶⁾ Information regarding the correlation between the pulse frequency and max. output current/output frequency is provided in the SINAMICS Low Voltage Configuration Manual.

⁷⁾ The specified power losses are the maximum values at 100% utilization. The values are lower under normal operating conditions.

⁸⁾ In conjunction with the specified fuses or circuit breakers.

⁹⁾ Current required for reliably triggering protective devices.

Technical specifications (continued)

Line voltage 380 ... 480 V 3 AC		SINAMICS S150 Converter Cabinet Units				
		6SL3710- 7LE37-5AA3	6SL3710- 7LE38-4AA3	6SL3710- 7LE41-0AA3	6SL3710- 7LE41-2AA3	6SL3710- 7LE41-4AA3
Type rating						
• At I_L (50 Hz 400 V) ¹⁾	kW	400	450	560	710	800
• At I_H (50 Hz 400 V) ¹⁾	kW	315	400	450	560	710
• At I_L (60 Hz 460 V) ²⁾	hp	600	700	800	900	1150
• At I_H (60 Hz 460 V) ²⁾	hp	450	600	700	900	1000
Output current						
• Rated current $I_{rated O}$	A	745	840	985	1260	1405
• Base-load current I_L ³⁾	A	725	820	960	1230	1370
• Base-load current I_H ⁴⁾	A	570	700	860	1127	1257
• Maximum current $I_{max O}$	A	1087	1230	1440	1845	2055
Infeed/regenerative feedback current						
• Rated input current $I_{rated I}$	A	674	759	888	1133	1262
• Maximum input current $I_{max I}$	A	1118	1260	1477	1891	2107
Current demand, max. ⁵⁾						
• 24 V DC aux. power supply	A	Internal	Internal	Internal	Internal	Internal
Pulse frequency ⁶⁾						
• Rated frequency	kHz	1.25	1.25	1.25	1.25	1.25
• Pulse frequency, max.						
- Without current derating	kHz	1.25	1.25	1.25	1.25	1.25
- With current derating	kHz	7.5	7.5	7.5	7.5	7.5
Power loss, max. ⁷⁾						
• At 50 Hz 400 V	kW	20.63	21.1	27.25	33.05	33.95
• At 60 Hz 460 V	kW	21.75	22.25	28.65	34.85	35.85
Cooling air requirement		m ³ /s	1.96	1.96	2.6	2.6
Sound pressure level L_{pA} (1 m) at 50/60 Hz		dB	77/79	77/79	77/79	78/80
Cable length, max.						
• Shielded	m	300	300	300	300	300
• Unshielded	m	450	450	450	450	450
Degree of protection			IP20	IP20	IP20	IP20
Dimensions						
• Width	mm	2200	2200	2800	2800	2800
• Height	mm	2000	2000	2000	2000	2000
• Depth	mm	600	600	600	600	600
Weight (without options), approx.		kg	1731	1778	2408	2408
Short-circuit current rating according to IEC ⁸⁾		kA	65	65	84	100
Minimum short-circuit current ⁹⁾		A	15000	2000	2500	3200
Frame sizes						
• Active Interface Module		HI	HI	JI	JI	JI
• Active Line Module		HX	HX	JX	JX	JX
• Motor Module		HX	HX	JX	JX	JX

Note:

The power data in hp units is based on the NEC/CEC standards for the North American market. Information about line supply connections, motor connections and cabinet grounding can be found under **Cable cross-sections and connections**.

¹⁾ Rated output of a typical 6-pole standard induction motor based on I_L or I_H for 400 V 3 AC 50 Hz.

²⁾ Rated output of a typical 6-pole standard induction motor based on I_L or I_H for 460 V 3 AC 60 Hz.

³⁾ The base-load current I_L is based on a load cycle of 110% for 60 s or 150% for 10 s with a load cycle duration of 300 s.

⁴⁾ The base-load current I_H is based on a duty cycle of 150% for 60 s or 160% for 10 s with a duty cycle duration of 300 s.

⁵⁾ If the drive closed-loop control is still to remain active when the line supply fails, the equipment must be provided with an external 24 V DC supply.

⁶⁾ Information regarding the correlation between the pulse frequency and max. output current/output frequency is provided in the SINAMICS Low Voltage Configuration Manual.

⁷⁾ The specified power losses are the maximum values at 100% utilization. The values are lower under normal operating conditions.

⁸⁾ In conjunction with the specified fuses or circuit breakers.

⁹⁾ Current required for reliably triggering protective devices.

SINAMICS S150 Converter Cabinet Units

Converter cabinet units

Technical specifications (continued)

Line voltage 500 ... 690 V 3 AC		SINAMICS S150 Converter Cabinet Units					
		6SL3710-7LG28-5AA3	6SL3710-7LG31-0AA3	6SL3710-7LG31-2AA3	6SL3710-7LG31-5AA3	6SL3710-7LG31-8AA3	6SL3710-7LG32-2AA3
Type rating							
• At I_L (50 Hz 690 V) ¹⁾	kW	75	90	110	132	160	200
• At I_H (50 Hz 690 V) ¹⁾	kW	55	75	90	110	132	160
• At I_L (50 Hz 500 V) ¹⁾	kW	55	55	75	90	110	132
• At I_H (50 Hz 500 V) ¹⁾	kW	45	55	75	90	90	110
• At I_L (60 Hz 575 V) ²⁾	hp	75	75	100	150	150	200
• At I_H (60 Hz 575 V) ²⁾	hp	75	75	100	125	150	200
Output current							
• Rated current $I_{rated O}$	A	85	100	120	150	175	215
• Base-load current I_L ³⁾	A	80	95	115	142	170	208
• Base-load current I_H ⁴⁾	A	76	89	117	134	157	192
• Maximum current $I_{max O}$	A	120	142	172	213	255	312
Infeed/regenerative feedback current							
• Rated current $I_{rated I}$	A	86	99	117	144	166	202
• Maximum current $I_{max I}$	A	125	144	170	210	253	308
Current demand, max. ⁵⁾							
• 24 V DC aux. power supply	A	Internal	Internal	Internal	Internal	Internal	Internal
Pulse frequency ⁶⁾							
• Rated frequency	kHz	1.25	1.25	1.25	1.25	1.25	1.25
• Pulse frequency, max.							
- Without current derating	kHz	1.25	1.25	1.25	1.25	1.25	1.25
- With current derating	kHz	7.5	7.5	7.5	7.5	7.5	7.5
Power loss, max. ⁷⁾							
• At 50 Hz 690 V	kW	5.12	5.38	5.84	5.75	11.02	11.44
• At 60 Hz 575 V	kW	4.45	4.65	5.12	4.97	11.15	11.56
Cooling air requirement		m ³ /s	0.58	0.58	0.58	0.58	1.19
Sound pressure level L_{pA} (1 m) at 50/60 Hz		dB	71/73	71/73	71/73	71/73	75/77
Cable length, max.							
• Shielded	m	300	300	300	300	300	300
• Unshielded	m	450	450	450	450	450	450
Degree of protection			IP20	IP20	IP20	IP20	IP20
Dimensions							
• Width	mm	1400	1400	1400	1400	1600	1600
• Height	mm	2000	2000	2000	2000	2000	2000
• Depth	mm	600	600	600	600	600	600
Weight (without options), approx.		kg	708	708	708	708	892
Short-circuit current rating according to IEC ⁸⁾		kA	65	65	65	65	65
Minimum short-circuit current ⁹⁾		A	1000	1000	1300	1800	2500
Frame size							
• Active Interface Module		FI	FI	FI	FI	GI	GI
• Active Line Module		FX	FX	FX	FX	GX	GX
• Motor Module		FX	FX	FX	FX	GX	GX

Note:

The power data in hp units is based on the NEC/CEC standards for the North American market. Information about line supply connections, motor connections and cabinet grounding can be found under **Cable cross-sections and connections**.

¹⁾ Rated output of a typical 6-pole standard induction motor based on I_L or I_H for 690 V 3 AC 50 Hz.

²⁾ Rated output of a typical 6-pole standard induction motor based on I_L or I_H for 575 V 3 AC 60 Hz.

³⁾ The base-load current I_L is based on a load cycle of 110% for 60 s or 150% for 10 s with a load cycle duration of 300 s.

⁴⁾ The base-load current I_H is based on a duty cycle of 150% for 60 s or 160% for 10 s with a duty cycle duration of 300 s.

⁵⁾ If the drive closed-loop control is still to remain active when the line supply fails, the equipment must be provided with an external 24 V DC supply.

⁶⁾ Information regarding the correlation between the pulse frequency and max. output current/output frequency is provided in the SINAMICS Low Voltage Configuration Manual.

⁷⁾ The specified power losses are the maximum values at 100% utilization. The values are lower under normal operating conditions.

⁸⁾ In conjunction with the specified fuses or circuit breakers.

⁹⁾ Current required for reliably triggering protective devices.

Technical specifications (continued)

Line voltage 500 ... 690 V 3 AC		SINAMICS S150 Converter Cabinet Units					
		6SL3710-7LG32-6AA3	6SL3710-7LG33-3AA3	6SL3710-7LG34-1AA3	6SL3710-7LG34-7AA3	6SL3710-7LG35-8AA3	6SL3710-7LG37-4AA3
Type rating							
• At I_L (50 Hz 690 V) ¹⁾	kW	250	315	400	450	560	710
• At I_H (50 Hz 690 V) ¹⁾	kW	200	250	315	400	450	630
• At I_L (50 Hz 500 V) ¹⁾	kW	160	200	250	315	400	500
• At I_H (50 Hz 500 V) ¹⁾	kW	132	160	200	250	315	450
• At I_L (60 Hz 575 V) ²⁾	hp	250	300	400	450	600	700
• At I_H (60 Hz 575 V) ²⁾	hp	200	250	350	450	500	700
Output current							
• Rated current $I_{rated O}$	A	260	330	410	465	575	735
• Base-load current I_L ³⁾	A	250	320	400	452	560	710
• Base-load current I_H ⁴⁾	A	233	280	367	416	514	657
• Maximum current $I_{max O}$	A	375	480	600	678	840	1065
Infeed/regenerative feedback current							
• Rated current $I_{rated I}$	A	242	304	375	424	522	665
• Maximum current $I_{max I}$	A	370	465	619	700	862	1102
Current demand, max. ⁵⁾							
• 24 V DC aux. power supply	A	Internal	Internal	Internal	Internal	Internal	Internal
Pulse frequency ⁶⁾							
• Rated frequency	kHz	1.25	1.25	1.25	1.25	1.25	1.25
• Pulse frequency, max.							
- Without current derating	kHz	1.25	1.25	1.25	1.25	1.25	1.25
- With current derating	kHz	7.5	7.5	7.5	7.5	7.5	7.5
Power loss, max. ⁷⁾							
• At 50 Hz 690 V	kW	11.97	12.69	19.98	20.55	24.05	30.25
• At 60 Hz 575 V	kW	12.03	12.63	18.86	19.47	22.85	28.75
Cooling air requirement		m ³ /s	1.19	1.19	1.96	1.96	2.6
Sound pressure level L_{pA} (1 m) at 50/60 Hz		dB	75/77	75/77	77/79	77/79	77/79
Cable length, max.							
• Shielded	m	300	300	300	300	300	300
• Unshielded	m	450	450	450	450	450	450
Degree of protection			IP20	IP20	IP20	IP20	IP20
Dimensions							
• Width	mm	1600	1600	2200	2200	2200	2800
• Height	mm	2000	2000	2000	2000	2000	2000
• Depth	mm	600	600	600	600	600	600
Weight (without options), approx.		kg	892	892	1716	1716	2300
Short-circuit current rating according to IEC ⁸⁾		kA	65	65	65	65	85
Minimum short-circuit current ⁹⁾		A	3000	4500	4500	7000	9000
Frame size							
• Active Interface Module		GI	GI	HI	HI	HI	J1
• Active Line Module		GX	GX	HX	HX	HX	JX
• Motor Module		GX	GX	HX	HX	HX	JX

Note:

The power data in hp units is based on the NEC/CEC standards for the North American market. Information about line supply connections, motor connections and cabinet grounding can be found under **Cable cross-sections and connections**.

¹⁾ Rated output of a typical 6-pole standard induction motor based on I_L or I_H for 690 V 3 AC 50 Hz.

²⁾ Rated output of a typical 6-pole standard induction motor based on I_L or I_H for 575 V 3 AC 60 Hz.

³⁾ The base-load current I_L is based on a load cycle of 110% for 60 s or 150% for 10 s with a load cycle duration of 300 s.

⁴⁾ The base-load current I_H is based on a duty cycle of 150% for 60 s or 160% for 10 s with a duty cycle duration of 300 s.

⁵⁾ If the drive closed-loop control is still to remain active when the line supply fails, the equipment must be provided with an external 24 V DC supply.

⁶⁾ Information regarding the correlation between the pulse frequency and max. output current/output frequency is provided in the SINAMICS Low Voltage Configuration Manual.

⁷⁾ The specified power losses are the maximum values at 100% utilization. The values are lower under normal operating conditions.

⁸⁾ In conjunction with the specified fuses or circuit breakers.

⁹⁾ Current required for reliably triggering protective devices.

SINAMICS S150 Converter Cabinet Units

Converter cabinet units

Technical specifications (continued)

Line voltage 500 ... 690 V 3 AC		SINAMICS S150 Converter Cabinet Units			
		6SL3710-7LG38-1AA3	6SL3710-7LG38-8AA3	6SL3710-7LG41-0AA3	6SL3710-7LG41-3AA3
Type rating					
• At I_L (50 Hz 690 V) ¹⁾	kW	800	900	1000	1200
• At I_H (50 Hz 690 V) ¹⁾	kW	710	800	900	1000
• At I_L (50 Hz 500 V) ¹⁾	kW	560	630	710	900
• At I_H (50 Hz 500 V) ¹⁾	kW	500	560	630	800
• At I_L (60 Hz 575 V) ²⁾	hp	800	900	1000	1250
• At I_H (60 Hz 575 V) ²⁾	hp	700	800	900	1000
Output current					
• Rated current $I_{rated O}$	A	810	910	1025	1270
• Base-load current I_L ³⁾	A	790	880	1000	1230
• Base-load current I_H ⁴⁾	A	724	814	917	1136
• Maximum current $I_{max O}$	A	1185	1320	1500	1845
Infeed/regenerative feedback current					
• Rated current $I_{rated I}$	A	732	821	923	1142
• Maximum current $I_{max I}$	A	1218	1367	1537	1905
Current demand, max. ⁵⁾					
• 24 V DC aux. power supply	A	Internal	Internal	Internal	Internal
Pulse frequency ⁶⁾					
• Rated frequency	kHz	1.25	1.25	1.25	1.25
• Pulse frequency, max.					
- Without current derating	kHz	1.25	1.25	1.25	1.25
- With current derating	kHz	7.5	7.5	7.5	7.5
Power loss, max. ⁷⁾					
• At 50 Hz 690 V	kW	34.45	34.65	36.15	42.25
• At 60 Hz 575 V	kW	32.75	32.85	34.25	39.25
Cooling air requirement		m ³ /s	2.6	2.6	2.6
Sound pressure level L_{pA} (1 m) at 50/60 Hz		dB	77/79	77/79	77/79
Cable length, max.					
• Shielded	m	300	300	300	300
• Unshielded	m	450	450	450	450
Degree of protection			IP20	IP20	IP20
Dimensions					
• Width	mm	2800	2800	2800	2800
• Height	mm	2000	2000	2000	2000
• Depth	mm	600	600	600	600
Weight (without options), approx.		kg	2408	2408	2408
Short-circuit current rating according to IEC ⁸⁾		kA	85	85	85
Minimum short-circuit current ⁹⁾		A	2000	2000	2500
Frame size					
• Active Interface Module		J1	J1	J1	J1
• Active Line Module		JX	JX	JX	JX
• Motor Module		JX	JX	JX	JX

Note:

The power data in hp units is based on the NEC/CEC standards for the North American market. Information about line supply connections, motor connections and cabinet grounding can be found under **Cable cross-sections and connections**.

¹⁾ Rated output of a typical 6-pole standard induction motor based on I_L or I_H for 690 V 3 AC 50 Hz.

²⁾ Rated output of a typical 6-pole standard induction motor based on I_L or I_H for 575 V 3 AC 60 Hz.

³⁾ The base-load current I_L is based on a load cycle of 110% for 60 s or 150% for 10 s with a load cycle duration of 300 s.

⁴⁾ The base-load current I_H is based on a duty cycle of 150% for 60 s or 160% for 10 s with a duty cycle duration of 300 s.

⁵⁾ If the drive closed-loop control is still to remain active when the line supply fails, the equipment must be provided with an external 24 V DC supply.

⁶⁾ Information regarding the correlation between the pulse frequency and max. output current/output frequency is provided in the SINAMICS Low Voltage Configuration Manual.

⁷⁾ The specified power losses are the maximum values at 100% utilization. The values are lower under normal operating conditions.

⁸⁾ In conjunction with the specified fuses or circuit breakers.

⁹⁾ Current required for reliably triggering protective devices.

Characteristic curves

Derating data

SINAMICS S150 converter cabinet units and the associated system components are rated for an ambient temperature of 40 °C and installation altitudes up to 2000 m above sea level.

At ambient temperatures > 40 °C, the output current must be reduced. Ambient temperatures above 50 °C are not permissible.

At installation altitudes > 2000 m above sea level, it must be taken into account that the air pressure, and therefore air density, decreases as the height increases. As a consequence, the cooling efficiency and the insulation capacity of the air also decrease.

Due to the reduced cooling efficiency, it is necessary, on the one hand, to reduce the ambient temperature and on the other hand, to lower heat loss in the converter cabinet unit by reducing the output current, whereby ambient temperatures lower than 40 °C may be offset to compensate.

The following table lists the permissible output currents depending on the installation altitude and ambient temperature for the various degrees of protection. The specified values already include a permitted compensation in respect of installation altitude and ambient temperatures < 40 °C (temperature at the air intake of the converter cabinet unit).

The values apply under the precondition that the cooling air flow stated in the technical specifications is ensured by the way the devices are installed in the cabinet.

As additional measure for installation altitudes from 2000 m up to 5000 m, an isolating transformer is required in order to reduce transient overvoltages according to EN 60664-1.

[For additional information, please refer to the SINAMICS Low Voltage Engineering Manual.](#)

Degree of protection	Installation altitude above sea level m	Current derating factor (as a percentage of the rated current) for an ambient / air intake temperature of						
		20 °C	25 °C	30 °C	35 °C	40 °C	45 °C	50 °C
IP20, IP21, IP23, IP43	0 ... 2000						93.3 %	86.7 %
	2001 ... 2500					96.3 %		
	2501 ... 3000		100 %		98.7 %			
	3001 ... 3500							
	3501 ... 4000				96.3 %			
	4001 ... 4500			97.5 %				
	4501 ... 5000	98.2 %						
IP54	0 ... 2000					93.3 %	86.7 %	80.0 %
	2001 ... 2500				96.3 %	89.8 %		
	2501 ... 3000		100 %	98.7 %	92.5 %			
	3001 ... 3500			94.7 %				
	3501 ... 4000		96.3 %	90.7 %				
	4001 ... 4500	97.5 %	92.1 %					
	4501 ... 5000	93.0 %						

SINAMICS S150 Converter Cabinet Units

Converter cabinet units

Characteristic curves (continued)

Current derating depending on the pulse frequency

To reduce motor noise or to increase output frequency, the pulse frequency can be increased relative to the factory setting (1.25 kHz or 2 kHz). When the pulse frequency is increased, the derating factor of the output current must be taken into account. This derating factor must be applied to the currents specified in the technical specifications.

For additional information, please refer to the SINAMICS Low Voltage Engineering Manual.

Derating factor of the output current depending on the pulse frequency for devices with a rated pulse frequency of 2 kHz

SINAMICS S150 converter cabinet unit	Type rating at 400 V	Output current at 2 kHz	Derating factor at the pulse frequency				
			2.5 kHz	4 kHz	5 kHz	7.5 kHz	8 kHz
6SL3710-...	kW	A					
380 ... 480 V 3 AC							
7LE32-1AA3	110	210	95 %	82 %	74 %	54 %	50 %
7LE32-6AA3	132	260	95 %	83 %	74 %	54 %	50 %
7LE33-1AA3	160	310	97 %	88 %	78 %	54 %	50 %
7LE33-8AA3	200	380	96 %	87 %	77 %	54 %	50 %
7LE35-0AA3	250	490	94 %	78 %	71 %	53 %	50 %

Derating factor of the output current depending on the pulse frequency for devices with a rated pulse frequency of 1.25 kHz

SINAMICS S150 converter cabinet unit	Type rating at 400 V or 690 V	Output current at 1.25 kHz	Derating factor at the pulse frequency				
			2 kHz	2.5 kHz	4 kHz	5 kHz	7.5 kHz
6SL3710-...	kW	A					
380 ... 480 V 3 AC							
7LE36-1AA3	315	605	83 %	72 %	64 %	60 %	40 %
7LE37-5AA3	400	745	83 %	72 %	64 %	60 %	40 %
7LE38-4AA3	450	840	87 %	79 %	64 %	55 %	40 %
7LE41-0AA3	560	985	92 %	87 %	70 %	60 %	50 %
7LE41-2AA3	710	1260	92 %	87 %	70 %	60 %	50 %
7LE41-4AA3	800	1405	97 %	95 %	74 %	60 %	50 %
500 ... 690 V 3 AC							
7LG28-5AA3	75	85	93 %	89 %	71 %	60 %	40 %
7LG31-0AA3	90	100	92 %	88 %	71 %	60 %	40 %
7LG31-2AA3	110	120	92 %	88 %	71 %	60 %	40 %
7LG31-5AA3	132	150	90 %	84 %	66 %	55 %	35 %
7LG31-8AA3	160	175	92 %	87 %	70 %	60 %	40 %
7LG32-2AA3	200	215	92 %	87 %	70 %	60 %	40 %
7LG32-6AA3	250	260	92 %	88 %	71 %	60 %	40 %
7LG33-3AA3	315	330	89 %	82 %	65 %	55 %	40 %
7LG34-1AA3	400	410	89 %	82 %	65 %	55 %	35 %
7LG34-7AA3	450	465	92 %	87 %	67 %	55 %	35 %
7LG35-8AA3	560	575	91 %	85 %	64 %	50 %	35 %
7LG37-4AA3	710	735	87 %	79 %	64 %	55 %	35 %
7LG38-1AA3	800	810	97 %	95 %	71 %	55 %	35 %
7LG38-8AA3	900	910	92 %	87 %	67 %	55 %	33 %
7LG41-0AA3	1000	1025	91 %	86 %	64 %	50 %	30 %
7LG41-3AA3	1200	1270	87 %	79 %	55 %	40 %	25 %

The following table lists the maximum achievable output frequency as a function of the pulse frequency:

Pulse frequency	Max. achievable output frequency
1.25 kHz	100 Hz
2 kHz	160 Hz
2.5 kHz	200 Hz
≥4 kHz	300 Hz

Characteristic curves (continued)**Overload capability**

The SINAMICS S150 converter cabinet units are equipped with an overload reserve to deal with breakaway torques, for example. If larger surge loads occur, this must be taken into account in the configuration. For drives with overload requirements, the appropriate base load current must, therefore, be used as a basis for the required load.

The criterion for overload is that the drive is operated with its base load current before and after the overload occurs on the basis of a duty cycle duration of 300 s.

For temporary, periodic duty cycles with high variations of load within the duty cycle, the relevant sections of the SINAMICS Low Voltage Engineering Manual must be observed.

The base-load current for a low overload I_L is the basis for a duty cycle of 110 % for 60 s or 150 % for 10 s.

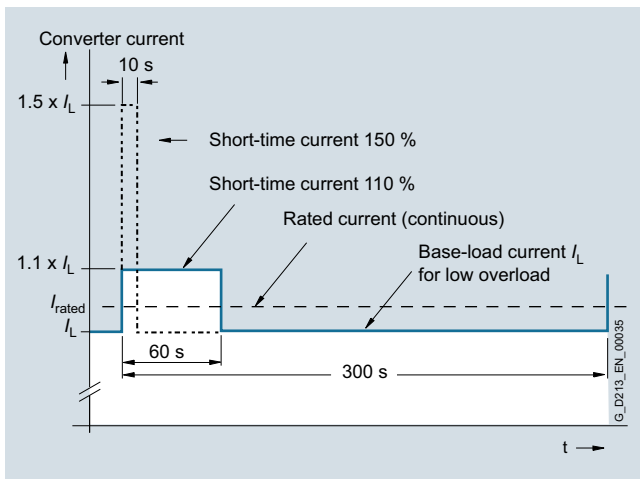

Low overload

The base-load current I_H for a high overload is based on a load cycle of 150 % for 60 s or 160 % for 10 s.

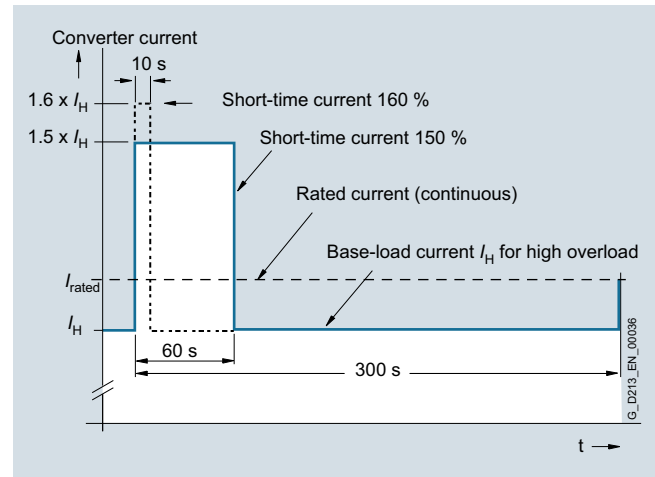

High overload

SINAMICS S150 Converter Cabinet Units

Converter cabinet units

Options

When ordering a converter with options, add the suffix "-Z" to the article number and then the order code(s) for the desired option(s).

Example:

**6SL3710-7LE32-1AA3-Z
M07+D60+...**

See also ordering examples.

Available options	Order code
Input side	
Use in the first environment according to EN 618003, Category C2 (TN-TT line supplies with grounded neutral point)	L00
Infeed module one level lower	L04
Surge suppression	L21
Main switch incl. fuses or circuit breakers	L26
Line filter monitoring	L40
EMC shielding busbar (cable connection from below) ¹⁾	M70
Output side	
dv/dt filter plus Voltage Peak Limiter	L07
Motor reactor	L08
dv/dt filter plus Voltage Peak Limiter	L10
Sine-wave filter (only for the voltage range 380 to 480 V, up to 200 kW)	L15
EMC shielding busbar (cable connection from below) ¹⁾	M70
Motor protection and safety functions	
EMERGENCY OFF pushbutton installed in the cabinet door	L45
EMERGENCY OFF category 0, 230 V AC or 24 V DC	L57
EMERGENCY STOP category 1, 230 V AC	L59
EMERGENCY STOP category 1, 24 V DC	L60
Thermistor motor protection (alarm)	L83
Thermistor motor protection (trip)	L84
Pt100 evaluation unit	L86
Insulation monitoring	L87
Additional touch protection	M60
Degree of protection increase	
Degree of protection IP21	M21
Degree of protection IP23	M23
Degree of protection IP43	M43
Degree of protection IP54	M54
Mechanical options	
Base 100 mm high, RAL 7022	M06
Cable-marshaling compartment 200 mm high, RAL 7035	M07
Line connection from above	M13
Motor connection from above	M78
Crane transport assembly (top-mounted)	M90
Safety Integrated	
Safety license for 1 axis	K01
Second SMC30 Sensor Module Cabinet-Mounted	K52
Terminal module for controlling the Safe Torque Off and Safe Stop 1 safety functions	K82
TM54F Terminal Module	K87
Safe Brake Adapter SBA, 230 V AC	K88

Available options	Order code
Other options	
CBC10 Communication Board	G20
CBE20 Communication Board	G33
TM150 temperature sensor evaluation unit	G51
TM31 Terminal Module	G60
Additional TM31 Terminal Module	G61
TB30 Terminal Board	G62
SMC10 Sensor Module Cabinet-Mounted	K46
SMC20 Sensor Module Cabinet-Mounted	K48
SMC30 Sensor Module Cabinet-Mounted	K50
VSM10 Voltage Sensing Module	K51
CU320-2 PN Control Unit	K95
Connection for external auxiliary equipment	L19
Cabinet lighting with service socket	L50
Cabinet anti-condensation heating	L55
25/125 kW braking unit for line voltages of 380 ... 480 V (110 ... 132 kW) and 660 ... 690 V (75 ... 132 kW)	L61
50/250 kW braking unit for line voltages of 380 ... 480 V (160 ... 800 kW) and 660 ... 690 V (160 ... 1200 kW)	L62
25/125 kW braking unit for line voltages of 500 ... 600 V (110 ... 132 kW)	L64
50/250 kW braking unit for line voltages of 500 ... 600 V (160 ... 1200 kW)	L65
Marking of all control cable wire ends	M91
Special cabinet paint finish ²⁾	Y09
One-line label for system identification, 40 × 80 mm	Y31
Two-line label for system identification, 40 × 180 mm	Y32
Four-line label for system identification, 40 × 180 mm	Y33
Documentation (standard: English/German)	
Documentation, production flowchart: One issue	B43
Documentation, production flowchart: Updated every two weeks	B44
Documentation, production flowchart: Updated every month	B45
Documentation in German	D00
Customer documentation (circuit diagram, terminal diagram, layout diagram) in DXF format	D02
Customer documentation as hard copy	D04
Preliminary version of customer documentation	D14
Documentation in Russian	D56
Documentation in English / French	D58
Documentation in English / Spanish	D60
Documentation in Italian	D72
Documentation in English	D76
Documentation in French	D77
Documentation in Spanish	D78
Documentation in English / Italian	D80
Documentation in Chinese	D84
Documentation in English / Chinese	D91
Documentation in English / Portuguese (Brazil)	D93
Documentation in English / Russian	D94

¹⁾ This option is listed for the input- and output-side options, but is only required once.

²⁾ The order code **Y..** requires data in plain text.

Options (continued)

Available options	Order code
Rating plate data (standard: English/German)	
Rating plate data in English/French	T58
Rating plate data in English/Spanish	T60
Rating plate data in English/Italian	T80
Rating plate data in English/Portuguese (Brazil)	T83
Rating plate data in English/Russian	T85
Rating plate data in English/Chinese	T91
Options specific to the chemical industry	
NAMUR terminal block	B00
Protective separation for 24 V supply (PELV)	B02
Outlet for external auxiliary equipment (uncontrolled)	B03
Options specific to the shipbuilding industry	
Marine version	M66
Individual certificate from Germanische Lloyd (GL)	E11
Individual certificate from Lloyds Register (LR)	E21
Individual certificate from Bureau Veritas (BV)	E31
Individual certificate from Det Norske Veritas (DNV)	E51
Individual cert. from American Bureau of Shipping (ABS)	E61
Individual cert. from Chinese Certification Society (CCS)	E71

Available options	Order code
Converter acceptance in presence of customer	
Visual acceptance	F03
Function test without motor	F71
Function test with test bay motor under no-load conditions	F75
Insulation test	F77
Customer-specific acceptance inspections (on request)	F97
Converter acceptance without the customer present	
Function test without motor	F72
Function test with test bay motor under no-load conditions	F74
Insulation test	F76

Option selection matrix

Certain options can mutually exclude one another (options that are not involved, are also not shown).

✓	Possible combination
–	Combination not possible

Electrical options

	L07	L08	L10	L15	L57	L59	L60	L61/ L64	L62/ L65	L87	K82	M78
L07		–	–	–	✓	✓	✓	✓	✓	✓	✓	–
L08	–		–	–	✓	✓	✓	✓	✓	✓	✓	–
L10	–	–		–	✓	✓	✓	✓	✓	✓	✓	–
L15	–	–	–		✓	✓	✓	✓	✓	✓	✓	–
L57	✓	✓	✓	✓		–	–	✓	✓	✓	✓	✓
L59	✓	✓	✓	✓	–		–	✓	✓	✓	✓	✓
L60	✓	✓	✓	✓	–	–		✓	✓	✓	✓	✓
L61/L64	✓	✓	✓	✓	✓	✓	✓		–	✓	✓	✓
L62/L65	✓	✓	✓	✓	✓	✓	✓	–		✓	✓	✓
L87	✓	✓	✓	✓	✓	✓	✓	✓	✓		– ¹⁾	✓
K82	✓	✓	✓	✓	✓	✓	✓	✓	✓	– ¹⁾		✓
M78	–	–	–	–	✓	✓	✓	✓	✓	✓	✓	

Mechanical/electrical options

	M06	M07	M13	M21	M23	M43	M54	M60	M66	M70	M78
M06		–	✓	✓	✓	✓	✓	✓	✓	✓	✓
M07	–		✓	✓	✓	✓	✓	✓	✓	✓	✓
M13	✓	✓		–	✓	✓	✓	✓	✓	– ²⁾	✓
M21	✓	✓	–		–	–	–	– ³⁾	–	✓	–
M23	✓	✓	✓	–		–	–	–	–	✓	✓
M43	✓	✓	✓	–	–		–	–	–	✓	✓
M54	✓	✓	✓	–	–	–		–	✓	✓	✓
M60	✓	✓	–	– ³⁾	–	–	–		✓	✓	–
M66	✓	✓	✓	–	–	–	✓	✓		✓	–
M70	✓	✓	– ²⁾	✓	✓	✓	✓	✓	✓		– ²⁾
M78	✓	✓	✓	–	✓	✓	✓	–	–	– ²⁾	

¹⁾ A combination of **L87** and **K82** is available on request.

²⁾ If the line connection (option **M13**) and the motor connection (option **M78**) are from above, the EMC shield bus is not required in the lower cabinet area.

³⁾ Can only be selected for converters in the voltage range 400 V to 250 kW and 690 V to 315 kW. The **M60** option is fitted as standard for higher outputs.

SINAMICS S150 Converter Cabinet Units

Converter cabinet units

Options (continued)

Other options

	G20	G33	G62	K46	K48	K50	K51	K52
G20		–	–	✓	✓	✓	✓	✓
G33	–		–	✓	✓	✓	✓	✓
G62	–	–		✓	✓	✓	✓	✓
K46	✓	✓	✓		–	–	–	–
K48	✓	✓	✓	–		–	–	–
K50	✓	✓	✓	–	–		–	✓
K51	✓	✓	✓	–	–	–		–
K52	✓	✓	✓	–	–	✓	–	

Documentation

	D00	D02	D14	D56	D58	D60	D72	D76	D77	D78	D80	D84	D91	D93	D94	D99
D00		✓	✓	✓	✓	✓	✓	✓	✓	✓	✓	✓	✓	✓	✓	–
D02	✓		✓	✓	✓	✓	✓	✓	✓	✓	✓	✓	✓	✓	✓	–
D14	✓	✓		✓	✓	✓	✓	✓	✓	✓	✓	✓	✓	✓	✓	–
D56	✓	✓	✓		✓	✓	✓	✓	✓	✓	✓	✓	✓	✓	–	–
D58	✓	✓	✓	✓		–	✓	–	–	✓	–	✓	–	–	–	–
D60	✓	✓	✓	✓	–		✓	–	✓	–	–	✓	–	–	–	–
D72	✓	✓	✓	✓	✓	✓		✓	✓	✓	–	✓	✓	✓	✓	–
D76	✓	✓	✓	✓	–	–	✓		✓	✓	–	✓	–	–	–	–
D77	✓	✓	✓	✓	–	✓	✓	✓		✓	✓	✓	✓	✓	✓	–
D78	✓	✓	✓	✓	✓	–	✓	✓	✓		✓	✓	✓	✓	✓	–
D80	✓	✓	✓	✓	–	–	–	–	✓	✓		✓	–	–	–	–
D84	✓	✓	✓	✓	✓	✓	✓	✓	✓	✓	✓		–	✓	✓	–
D91	✓	✓	✓	✓	–	–	✓	–	✓	✓	–	–		–	–	–
D93	✓	✓	✓	✓	–	–	✓	–	✓	✓	–	✓	–		–	–
D94	✓	✓	✓	–	–	–	✓	–	✓	✓	–	✓	–	–		–
D99	–	–	–	–	–	–	–	–	–	–	–	–	–	–	–	

Rating plate data

	T58	T60	T80	T83	T85	T91
T58		–	–	–	–	–
T60	–		–	–	–	–
T80	–	–		–	–	–
T83	–	–	–		–	–
T85	–	–	–	–		–
T91	–	–	–	–	–	

Options (continued)**Ordering examples****Example 1***Task:*

A drive system is required for a vehicle test stand to perform exhaust gas analysis which can simulate driving profiles and cycles as encountered in everyday traffic situations. This means for the drive system that the dynamometer must be operated both in the motoring as well as regenerating modes.

A drive with regenerative feedback into the line supply is required as regenerative operation is the predominant operating mode and dynamic switching operations are required.

The max. regenerative power is 200 kW. The drive converter must have degree of protection IP54 as a result of the environmental conditions. An installation altitude of < 1000 m and 45 °C as the maximum ambient temperature can be assumed. The windings must be equipped with Pt100 resistance thermometers and monitored by the drive converter for alarm and trip. A switch disconnecter must be provided to disconnect the converter from the 400 V power supply. In addition, the cabinet is to have a special paint finish in RAL 3002.

Solution:

Taking into account the derating factors for degree of protection IP54 and the increased ambient temperature of 45 °C, a converter with a minimum power rating of 223 kW should be configured.

A converter with a power rating of at least 250 kW and options **M54** (degree of protection IP54), **L26** (main switch including fuses), **L86** (Pt100 evaluation unit) and **Y09** (special paint finish) is selected.

The ordering data are as follows:

6SL3710-7LE35-0AA3-Z
M54+L26+L86+Y09

Cabinet color RAL 3002

Example 2*Task:*

A drive system is required for a conveyor belt in a brown-coal open-cast mine that is capable of both motor and generator operation. Since the conveyor belt must be capable of starting after a fault when loaded with bulk material, and it is possible for peak loads to occur where 1.5 times the power is required for up to 60 s, the drive system must be designed according to the overload requirements of such a case. The drive converter is installed in a climate-controlled container as a result of the environmental conditions typical of an open-cast mine. The installation altitude is 320 m above sea level and the maximum ambient temperature in the container is 35 °C. The drive is powered through a converter transformer from the medium-voltage system. The drive is connected to an isolated-neutral system and must have insulation monitoring. A motor with separately-driven fan is selected here as the motor is subject to a high load torque when starting and in the lower range. The fan supply voltage is 690 V and must be drawn from the drive converter. The required motor power is 420 kW.

Solution:

Since the converter is installed in an air-conditioned container, it can be designed with degree of protection IP20. The ambient temperature of 35 °C does not necessitate any additional derating. However, due to the specified overload conditions, the base load current I_{FH} (for high overload) must be applied. This results in a power of approx. 520 kW for the drive converter. The converter with article no. 6SL3710-7LG35-8AA3 must be selected.

Option **L87** (insulation monitoring) must be selected for insulation monitoring.

Option **L19** (connection for external auxiliaries) must be selected for the controlled outgoing feeder to power the separately driven fan.

The ordering data are as follows:

6SL3710-7LG35-8AA3-Z
L19+L87

SINAMICS S150 Converter Cabinet Units

Description of the options

Options

B00, B02, B03

Options compliant with NAMUR requirements

Exclusion list with other options:

The following restrictions and exclusions applicable to the NAMUR terminal block **B00** with regard to other available options must be taken into account.

Not permissible with options	Reason
L45, L57, L59, L60	A Category 0 EMERGENCY OFF is already provided in the NAMUR version. The forced line supply disconnection is connected at terminal -X2: 17, 18.
L83, L84	The B00 option already provides a PTC thermistor evaluation unit as standard (trip).
L19	Alternatively, option B03 can be selected. This provides a reduced scope for external auxiliaries.
L87	The insulation monitor monitors the complete electrically coupled network. An insulation monitor must therefore be provided on site.
G60	The B00 option already provides a Terminal Module TM31 as a standard feature.

With options **L50, L55, L86**, the connection is made as described in the standard. There is no wiring to the NAMUR terminal block.

B00

NAMUR terminal block

The terminal block is designed according to the requirements and directives of the standards association for measurement and control in the chemical industry (NAMUR recommendation NE37). I.e. terminals are specifically assigned to particular device functions. The inputs and outputs connected to the terminals fulfill PELV requirements (protective extra-low voltage) with protective separation.

The terminal block and associated functions have been reduced to the necessary minimum. Unlike the NAMUR recommendation, optional terminals are not available.

Terminal -X2:	Meaning	Default	Remarks
10	DI	ON (dynamic) / ON/OFF (static)	The effective mode can be encoded using a wire jumper at terminal -400: 9; 10 codable
11	DI	OFF (dynamic)	
12	DI	Faster	
13	DI	Slower	
14	DI	RESET	
15	DI	Interlock	
16	DI	Counter-clockwise	0 signal for CW rotating field 1 signal for CCW rotating field
17, 18		Supply disconnection	EMERGENCY OFF circuit
30, 31		Ready	Relay output (NO contact)
32, 33		Motor is turning	Relay output (NO contact)
34	DO (NO)	Fault	Relay output (changeover contact)
35	DO (COM)		
36	DO (NC)		
50, 51	AI 0/4 ... 20 mA	Speed setpoint	
60, 61	AO 0/4 ... 20 mA	Motor frequency	
62, 63	AO 0/4 ... 20 mA	Motor current	Motor current is default setting; can be reparameterized for other variables

The 24 V supply is provided on the plant side via terminals -X2: 1-3 (fused in the converter with 1 A). It must be ensured that the PELV safety requirements are fulfilled (protective extra-low voltage with protective separation).

Terminal -X2:	Meaning	
1	M	Reference conductor
2	P24	24 V DC supply
3	P24	24 V DC outgoing feeder

For temperature monitoring of explosion-proof motors, option **B00** includes a PTC thermistor. Exceeding the limit value causes a shutdown. The associated PTC sensor is connected to terminal -X3: 90, 91.

Terminal -X3:	Meaning	
90, 91	AI	Connection of PTC sensor

Options (continued)**B02****Protective separation for 24 V supply (PELV)**

If no protective separation for 24 V supply (PELV) is available at the customer site, this option is used to provide a second power supply to guarantee compliance with PELV. (Terminal assignments as for option **B00**, 24 V supply at terminals -X1:1, 2, 3 is not required)

Notice:

The option **B02** must always be combined with **B00**.

B03**Outgoing feeder for external auxiliaries (uncontrolled)**

If a motor fan is to be supplied with power from the plant, option **B03** provides an uncontrolled external outgoing feeder with a 10 A fuse. As soon as the supply voltage is present at the converter input, a voltage is also present at these terminals. This corresponds to the converter input voltage ($U = U_{line}$). You must take this into account when configuring an external fan.

Terminal -X1:	Meaning
1, 2, 3, PE	Outgoing feeder for external auxiliary equipment

Notice:

Option **B03** must always be combined with **B00**.

B43, B44, B45**Production flowcharts**

Production flowcharts are provided with options **B43** to **B45**. After the order has been clarified, these are e-mailed as a dual language (English/German) PDF file.

Option	Description
B43	Documentation - Production flowchart: One issue
B44	Documentation - Production flowchart: Updated every two weeks
B45	Documentation - Production flowchart: Updated every month

D02**Customer documentation (circuit diagram, terminal diagram, layout diagram) in DXF format**

Option **D02** can be used to order documents such as circuit diagrams, terminal diagrams, layout diagrams, and dimension drawings in DXF format, e.g. for further processing in AutoCAD systems.

D04**Customer documentation as hard copy**

Device documentation is supplied electronically on a CD-ROM as standard. If the customer also requires a hard copy of the documentation and selects option **D04**, the following documents will be supplied in a folder with the converter:

- Operating instructions
- Circuit diagram
- Terminal diagram
- Layout diagram
- Dimension drawing
- Spare parts list
- Test certificate

Regardless of whether option **D04** is selected, hard copies of the safety and transportation guidelines, a check list and a registration form are always supplied.

D14**Preliminary version of customer documentation**

If documents such as circuit diagrams, terminal diagrams, layout diagrams and dimension drawings are required in advance for the purpose of system engineering (integration of drive into higher-level systems, interface definition, installation, building planning, etc.), it is possible to order a draft copy of the documentation when ordering the converter cabinet units. These documents are then supplied electronically a few working days following receipt of the order. If the order includes options that fall outside the scope of standard delivery, these will not be covered by the documentation due to the obvious time constraints.

Documentation relating to the order is sent to the buyer by e-mail. The recipient's e-mail address must be specified with the order for this purpose. In the e-mail, the recipient will also receive a link (Internet address) for downloading general, non-order-specific documentation such as the Operating Instructions, Equipment Manual and Commissioning Instructions.

D58, D60, D80, D91, D93, D94**Documentation as language package**

If a documentation option is not selected, the relevant documentation is supplied as standard in English/German. When one of the options specified in the table is selected, the standard documentation language will be changed from English / German to the language combination provided by the option.

Order code	Language
D58	English/French
D60	English/Spanish
D80	English/Italian
D91	English/Chinese
D93	English/Portuguese (Brazil)
D94	English/Russian

D00, D56, D72, D76, D77, D78, D84**Documentation in a single language**

The documentation is also available in a single language, for example, to be able to order other language combinations.

If a further language is required for standard documentation in English/German, the option **D74** (documentation in English/German) must also be ordered in addition to that language.

Order code	Language
D00	German
D56	Russian
D72	Italian
D76	English
D77	French
D78	Spanish
D84	Chinese

E11 to E71**Individual certification**

The individual certification of the converter by the relevant certification body contains the expansions described in option **M66**.

- **E11** Individual certificate from Germanische Lloyd (GL)
- **E21** Individual certificate from Lloyds Register (LR)
- **E31** Individual certificate from Bureau Veritas (BV)
- **E51** Individual certificate from Det Norske Veritas (DNV)
- **E61** Individual cert. from American Bureau of Shipping (ABS)
- **E71** Individual cert. from Chinese Classification Society (CCS)

Note:

Several individual certificates can be combined.

SINAMICS S150 Converter Cabinet Units

Description of the options

Options (continued)

F03, F71, F72, F74, F75, F76, F77, F97 Converter acceptance inspections

Order code	Description
F03	<p>Visual acceptance</p> <p>The inspection includes the following:</p> <ul style="list-style-type: none"> • Check of degree of protection • Check of equipment (components) • Check of equipment identifiers • Check of clearance and creepage distances • Check of cables • Check of customer documentation • Submission of the acceptance report <p>The tests are carried out with the converter de-energized.</p>
F71 (witnessed by customer) F72 (not witnessed by customer)	<p>Function test without connected motor</p> <p>After the visual acceptance with the converter switched off, the converter is connected to rated voltage.</p> <p>No current at the converter output end.</p> <p>The inspection includes the following:</p> <ul style="list-style-type: none"> • Visual acceptance as described for option F03 • Check of power supply • Check of protective and monitoring devices (simulation) • Check of fans • Pre-charging test • Function test without connected motor • Submission of the acceptance report
F74 (not witnessed by customer) F75 (witnessed by customer)	<p>Function test with test bay motor under no-load conditions</p> <p>After the visual acceptance with the converter switched off, the converter is connected to rated voltage.</p> <p>A small current flows at the converter output end in order to operate the test bay motor under no-load conditions.</p> <p>The inspection includes the following:</p> <ul style="list-style-type: none"> • Visual acceptance as described for option F03 • Check of power supply • Check of protective and monitoring devices (simulation) • Check of fans • Pre-charging test • Function test with test bay motor under no-load conditions • Submission of the acceptance report
F76 (not witnessed by customer) F77 (witnessed by customer)	<p>Insulation test</p> <p>The inspection includes the following:</p> <ul style="list-style-type: none"> • High-voltage test • Measurement of the insulation resistance • Submission of the acceptance report
F97	<p>Customer-specific acceptance inspections (on request)</p> <p>If acceptance inspections that are not covered by the options F03, F71, F75, or F77 are required, customer-specific acceptance inspections/supplementary tests can be ordered using order code F97 on request and following technical clarification.</p>

G20 **CBC10 Communication Board**

The CBC10 Communication Board plugs into the option slot on the CU320-2 Control Unit. The CAN interface on the CBC10 has 2 SUB-D connections for input and output.

The CBC10 Communication Board is used to connect the CU320-2 Control Unit and thus the SINAMICS S150 to the CAN (Controller Area Network) protocol. The associated driver software fulfills the standards of the following CANopen specification of the CiA organization (CAN in Automation):

- Communication profiles according to DS 301
- Drive profile in accordance with DSP 402 (in this case Profile Velocity Mode)
- EDS (Electronic Data Sheet) in accordance with DSP 306
- Operational state signaling according to DSP 305

The CBC10 Communication Board plugs into the option slot on the CU320-2 Control Unit. The CAN interface on the CBC10 has two SUB-D connections for input and output.

It cannot be combined with option **G33**.

[Description of the CBC10 Communication Board → SINAMICS S120 chassis format units → System components → Supplementary system components.](#)

G33 **CBE20 Communication Board**

The CBE20 Communication Board can be used to connect the SINAMICS S150 to a PROFINET IO or Ethernet/IP network via a CU320-2 Control Unit. The CBE Communication Board plugs into the option slot on the CU320-2 Control Unit.

It cannot be combined with option **G20**.

Note:

Only one communication interface can be used in isochronous operation when the Communication Board CBE20 is used in a Control Unit CU320-2.

- CU320-2 DP: Either the DP interface of the Control Unit or the PN interfaces of the CBE20
- CU320-2 PN: Either the internal PN interfaces or the external PN interfaces of the CBE20

[Description of the CBE20 Communication Board → SINAMICS S120 chassis format units → System components → Supplementary system components.](#)

G51 **TM150 temperature sensor evaluation unit**

The TM150 Terminal Module is a DRIVE-CLiQ component that is used to acquire and evaluate data from several temperature sensors. The temperature is measured in a temperature range from -99 °C to +250 °C for the following temperature sensors:

- Pt100 (with monitoring for wire breakage and short-circuit)
- Pt1000 (with monitoring for wire breakage and short-circuit)
- KTY84 (with monitoring for wire breakage and short-circuit)
- PTC (with monitoring for short-circuit)
- Bimetallic NC contact (without monitoring)

For the temperature sensor inputs, for each terminal block the evaluation can be parameterized for 1×2-wire, 2×2-wire, 3-wire or 4-wire. There is no galvanic isolation in the TM150.

A maximum of 12 temperature sensors can be connected to the TM150 Terminal Module.

[Description of the TM150 Terminal Module → SINAMICS S120 chassis format units → System components → Supplementary system components.](#)

Options (continued)**G60****TM31 Terminal Module**

The TM31 Terminal Module is used to expand the customer terminal.

The following additional interfaces are available:

- 8 digital inputs
- 4 bidirectional digital inputs/outputs
- 2 relay outputs with changeover contact
- 2 analog inputs
- 2 analog outputs
- 1 temperature sensor input (KTY84-130/PTC)
- 2 DRIVE-CLiQ sockets
- 1 connection for the electronics power supply via the 24 V DC supply connector
- 1 PE connection

To simplify configuration and commissioning of the drive, the optional TM31 Terminal Module is already preset with various factory settings, which can then be selected when commissioning the system.

[Description of the TM31 Terminal Module](#) → [SINAMICS S120 chassis format units](#) → [System components](#) → [Supplementary system components](#).

For additional information, please refer to the [SINAMICS Low Voltage Engineering Manual](#).

G61**Additional TM31 Terminal Module**

With option **G61**, the number of digital inputs/outputs, as well as the number of analog inputs/outputs in the drive system can be expanded using a second TM31 Terminal Module (in addition to the TM31 Terminal Module that can be selected using option **G60**).

Note:

Option **G61** requires option **G60**.

G62**TB30 Terminal Board**

The TB30 Terminal Board supports the addition of digital inputs/digital outputs and analog inputs/analog outputs to the Control Unit. The TB30 Terminal Board plugs into the option slot on the Control Unit.

The following are located on the TB30 Terminal Board:

- Power supply for digital inputs/digital outputs
- 4 digital inputs
- 4 digital outputs
- 2 analog inputs
- 2 analog outputs

[Description of the TB30 Terminal Board](#) → [SINAMICS S120 chassis format units](#) → [System components](#) → [Supplementary system components](#).

K01**Safety license for 1 axis**

The Safety Integrated basic functions do not require a license. However, the Safety Integrated extended functions require a license for each axis equipped with safety functions. It is irrelevant which safety functions are used and how many. Option **K01** contains the license for one axis.

Subsequent licensing is possible in the Internet via the WEB License Manager by generating a license key:

www.siemens.com/automation/license

K46**SMC10 Sensor Module Cabinet-Mounted**

The SMC10 Sensor Module Cabinet-Mounted can be used to simultaneously sense the speed and the rotor position angle. The signals received from the resolver are converted here and made available to the closed-loop controller via the DRIVE-CLiQ interface for evaluation purposes.

The following encoder signals can be evaluated:

- 2-pole resolver
- Multi-pole resolver

The motor temperature can also be measured using KTY84-130 or PTC thermistors.

[Description of the SMC10 Sensor Module Cabinet-Mounted](#) → [SINAMICS S120 chassis format units](#) → [System components](#) → [Encoder system interface](#).

K48**SMC20 Sensor Module Cabinet-Mounted**

The SMC20 Sensor Module Cabinet-Mounted can be used to simultaneously sense the speed and position. The signals received from the incremental encoder are converted here and made available to the closed-loop controller via the DRIVE-CLiQ interface for evaluation purposes.

The following encoder signals can be evaluated:

- Incremental encoder sin/cos $1 V_{pp}$
- Absolute encoder EnDat 2.1
- SSI encoder with incremental signals sin/cos $1 V_{pp}$

The motor temperature can also be detected using KTY84-130 or PTC/Pt100 thermistors.

[Description of the SMC20 Sensor Module Cabinet-Mounted](#) → [SINAMICS S120 chassis format units](#) → [System components](#) → [Encoder system interface](#).

K50**SMC30 Sensor Module Cabinet-Mounted**

The SMC30 Sensor Module Cabinet-Mounted can be used to evaluate the encoders of motors without a DRIVE-CLiQ interface. External encoders can also be connected via the SMC30.

The following encoder signals can be evaluated:

- Incremental encoders TTL/HTL with and without wire break detection (wire break detection is only available with bipolar signals)
- SSI encoders with TTL/HTL incremental signals
- SSI encoders without incremental signals

The motor temperature can also be measured using KTY84-130 or PTC thermistors.

[Description of the SMC30 Sensor Module Cabinet-Mounted](#) → [SINAMICS S120 chassis format units](#) → [System components](#) → [Encoder system interface](#).

SINAMICS S150 Converter Cabinet Units

Description of the options

Options (continued)

K51

VSM10 Voltage Sensing Module

The VSM10 Voltage Sensing Module is used to measure the voltage characteristic on the motor side, so that the following function can be implemented:

- Operation of a permanent-magnet synchronous motor without encoder with the requirement to be able to connect to a motor that is already running (flying restart function)
- Quick flying restart of large induction motors: The time for the demagnetization of the motor is eliminated through the measurement of the voltage.

Description of the VSM10 Voltage Sensing Module → SINAMICS S120 chassis format units → System components → Supplementary system components.

K52

Second SMC30 Sensor Module Cabinet-Mounted

With option **K50**, the cabinet unit contains an SMC30 Sensor Module Cabinet-Mounted. An additional SMC30 (Option **K52**) Sensor Module enables reliable actual-value acquisition when using Safety Integrated extended functions (requires a license: Option **K01**).

Detailed and comprehensive instructions and information for the Safety Integrated functions can be found in the associated Function Manual.

K82

Terminal Module for controlling the Safe Torque Off and Safe Stop 1 safety functions

The terminal module controls the Safety Integrated Basic Functions Safe Torque Off (STO) and Safe Stop 1 (SS1) (time-controlled) over a wide voltage range from 24 V to 240 V DC/AC (terminology as defined in IEC 61800-5-2).

The integrated safety functions, starting from the Safety Integrated (SI) input terminals of the components (Control Unit and Power Module), satisfy the requirements of EN 61800-5-2, EN 60204-1, DIN EN ISO 13849-1 Category 3 for Performance Level (PL) d and IEC 61508 SIL 2.

With option **K82**, the requirements specified in EN 61800-5-2, EN 60204-1, DIN EN ISO 13849-1 Category 3 for Performance Level (PL) d and IEC 61508 SIL 2 are fulfilled.

The Safety Integrated functions using option **K82** are only available in conjunction with certified components and software versions.

The Safety Integrated functions of SINAMICS are generally certified by independent institutes. An up-to-date list of certified components is available on request from your local Siemens office.

K87

TM54F Terminal Module

The Terminal Module TM54F is a terminal expansion module with safe digital inputs and outputs to control the Safety Integrated functions.

The TM54F is directly connected to a Control Unit via DRIVE-CLiQ. Each Control Unit can be precisely assigned to one TM54F.

Note:

It is not permissible to connect Motor Modules or Line Modules to a TM54F.

The TM54F provides 4 fail-safe digital outputs and 10 fail-safe digital inputs. A fail-safe digital output consists of one 24 V DC switching output, one output switching to ground and one digital input to check the switching state. A fail-safe digital input consists of two digital inputs.

Description of the TM54F Terminal Module → SINAMICS S120 chassis format units → System components → Supplementary system components.

K88

SBA Safe Brake Adapter, 230 V AC

The Safe Brake Control (SBC) is a safety function that is used in safety-relevant applications, for example in presses or rolling mills. In the no-current state, the brake acts on the drive motor using spring force. The brake is released when current flows in it (low active).

The Safe Brake Adapter is already installed in the cabinet unit in the factory. A source of power is connected to terminal -X12 on the Safe Brake Adapter. For control, a connection is established between the Safe Brake Adapter and the Control Interface Module in the factory using a cable harness.

On the plant side, to control the brake, a connection must be established between terminal -X14 on the Safe Brake Adapter and the brake.

Description of the SBA Safe Brake Adapter → SINAMICS S120 chassis format units → System components → Supplementary system components.

K95

CU320-2 PN Control Unit (PROFINET)

Instead of the CU320-2 DP (PROFIBUS) Control Unit provided as standard, the drive is delivered with a CU320-2 PN Control Unit (PROFINET), including a CompactFlash card.

Description of the CU320-2 Control Unit → SINAMICS S120 chassis format units → System components → Control Units.

L00

Use in the first environment according to EN 61800-3, Category C2 (TN/TT supply systems with grounded neutral point)

To limit interference emission, the converter includes as standard a radio interference suppression filter according to the EMC product standard EN 61800-3, Category C3 (use in the industrial environment or in the second environment).

By using the optionally available line filter (option **L00**), up to a motor cable length of 300 m on grounded line supplies, the converters are suitable for use according to Category C2 (residential area or first environment).

However, complying with the limit values in the standard means that all of the relevant installation specifications regarding grounding and shielding must be strictly observed.

Notes on this are provided in the SINAMICS Low Voltage Configuration Manual as well as in the appropriate operating instructions.

Options (continued)**L04****Infeed module one level lower**

With this option, an infeed (Active Line Module/Active Interface Module) rated one power level lower than the Motor Module (inverter) is used.

For instance, this option is suitable for the following applications:

- When the Motor Module is operated at pulse frequencies greater than the rated pulse frequency, which means that the output power is reduced (current derating as a function of the pulse frequency).
- When the rated power is demanded when generating, and the system losses are covered by the Motor Module.
- When using motors with a higher efficiency and/or a lower power factor when compared to typical standard induction motors.
- The maximum current of the Motor Module is demanded below the maximum power of the unit, e.g. drives with a high breakaway torque.

When using option **L04**, the following restrictions must always be taken into consideration:

- The rated output current of the Motor Module is only available as long as the infeed (Active Line Module) is not loaded with the rated power.
- For line undervoltage conditions, the output power is reduced linearly with the line voltage.
- The unit should be operated with a system power factor $\cos \varphi = 1$ (this is the factory setting) and should only provide the active power. Additional compensation of reactive power from the power system is not advisable.

Option **L04** is available for the following cabinet units:

SINAMICS S150 converter cabinet unit	Type rating at 400 V	Permissible currents		
		Output	Input Standard	With option L04
6SL3710-...	kW	A	A	A
Line voltage 380 ... 480 V 3 AC				
7LE33-1AA3	160	310	310	260
7LE35-0AA3	250	490	490	380
7LE36-1AA3	315	605	605	490
7LE37-5AA3	400	745	745	605
7LE41-0AA3	560	985	985	840

L07**dv/dt filter compact plus Voltage Peak Limiter**

dv/dt filters compact plus VPL (**V**oltage **P**eak **L**imiter) limit the voltage rate-of-rise dv/dt to values of $< 1600 \text{ V}/\mu\text{s}$ and the typical voltage peaks to the following values in accordance with the limit value curve A according to IEC 60034-25: 2007:

- $< 1150 \text{ V}$ at $U_{\text{line}} < 575 \text{ V}$
- $< 1400 \text{ V}$ at $660 \text{ V} < U_{\text{line}} < 690 \text{ V}$

The dv/dt filter compact plus VPL functionally consists of two components that are supplied as a compact mechanical unit, the dv/dt reactor and the voltage limiting network (VPL), which limits voltage peaks and feeds back the energy to the DC link.

It is so compact that it can be completely integrated into the cabinet, even for high power ratings. A supplementary cabinet is not required.

By using a dv/dt filter compact plus VPL, standard motors with standard insulation and without insulated bearings can be used with supply voltages up to 690 V in converter operation.

The power losses stated in Section System components → Motor-side components → dv/dt filter compact plus VPL can be used to determine the total losses for engineering purposes.

dv/dt filters compact plus VPL are designed for the following maximum motor cable lengths:

- Shielded cables 100 m (e.g. Protodur NYCWY)
- Unshielded cables: 150 m (e.g. Protodur NYY)

For longer cable lengths ($> 100 \text{ m}$ shielded, $> 150 \text{ m}$ unshielded), the dv/dt filter plus VPL (option **L10**) should be used.

Notice:

- Operation with output frequencies $< 10 \text{ Hz}$ is permissible for max. 5 min.
- The maximum permissible output frequency is 150 Hz.

When using dv/dt filters, restrictions regarding permissible pulse frequencies must be observed.

For additional information, please refer to the SINAMICS Low Voltage Engineering Manual.

Note:

Option **L07** cannot be combined with the following options:

- **L08** (motor reactor)
- **L10** (dv/dt filter plus VPL)
- **L15** (sine-wave filter)
- **M78** (motor connection from above)

L08**Motor reactor**

Motor reactors reduce the voltage load on the motor windings by reducing the voltage gradients at the motor terminals that occur during converter operation. At the same time, the capacitive charge/discharge currents that place an additional load on the converter output when long motor cables are used, are reduced.

The maximum permissible output frequency when a motor reactor is used is 150 Hz.

The power losses stated in Section System components → Motor-side components → Motor reactors can be used to determine the total losses for engineering purposes.

Note:

Option **L08** cannot be combined with the following options:

- **L07** (dv/dt filter compact plus VPL)
- **L10** (dv/dt filter plus VPL)
- **L15** (sine-wave filter)
- **M78** (motor connection from above)

SINAMICS S150 Converter Cabinet Units

Description of the options

Options (continued)

L10

dv/dt filter plus Voltage Peak Limiter

dv/dt filter plus VPL (**V**oltage **P**eak **L**imiter) limit the voltage rate-of-rise dv/dt to values < 500 V/μs and the typical voltage peaks to the following values in accordance with the limit value curve according to IEC/TS 60034-17: 2006:

- < 1000 V at $U_{line} < 575$ V
- < 1250 V at 660 V < $U_{line} < 690$ V

The dv/dt filter plus VPL functionally consists of two components, the dv/dt reactor and the voltage limiting network (VPL), which limits voltage peaks and feeds the energy back to the DC link.

Depending on the converter power, option **L10** can be accommodated in the converter cabinet unit or an additional cabinet is required with a width of 400 mm or 600 mm.

Voltage range	Installation of the dv/dt filter plus VPL		
	in the converter (without supplementary cabinet)	in the supplementary cabinet	
		400 mm wide	600 mm wide
380 ... 480 V	110 ... 250 kW	315 ... 450 kW	560 ... 800 kW
500 ... 690 V	75 ... 315 kW	400 ... 560 kW	710 ... 1200 kW

By using a dv/dt filter plus VPL, standard motors with standard insulation and without insulated bearings can be used with supply voltages up to 690 V in converter operation.

dv/dt filters plus VPL are designed for the following maximum motor cable lengths:

- Shielded cables 300 m (e.g. Protodur NYCWY)
- Unshielded cables: 450 m (e.g. Protodur NYY)

For cable lengths < 100 m shielded or < 150 m unshielded, the dv/dt filter compact plus VPL (option **L07**) can be advantageously used.

The power losses stated in Section System components → Motor-side components → dv/dt filter plus VPL can be used to determine the total losses for engineering purposes.

Notice:

The maximum permissible output frequency is 150 Hz.

When using dv/dt filters, restrictions regarding permissible pulse frequencies must be observed.

For additional information, please refer to the [SINAMICS Low Voltage Engineering Manual](#).

Note:

Parts of option **L10** do not have nickel-plated copper busbars.

Option **L10** cannot be combined with the following options:

- **L07** (dv/dt filter compact plus VPL)
- **L08** (motor reactor)
- **L15** (sine-wave filter)
- **M78** (motor connection from above)

L15

Sine-wave filter

Sine-wave filters are available for converters with a power rating of up to 250 kW (380 V to 480 V). The sine-wave filter at the converter output supplies almost perfect sinusoidal voltages at the motor so that standard motors can be used without special cables or power derating. Standard cables can be used to connect the motor. The max. permissible motor cable length is limited to 300 m.

The power losses stated in Section System components → Motor-side components → Sine-wave filter can be used to determine the total losses for engineering purposes.

Note:

In conjunction with the option **L15**, the pulse frequency of the converter must be increased. This reduces the power available at the drive converter output (derating factor 0.88). The modulation depth of the output voltage decreases to approx. 85% (380 V to 480 V). The maximum output frequency is 150 Hz. It should be noted that the reduced voltage at the motor terminals compared with the rated motor voltage means that the motor switches to field weakening mode earlier.

Note:

Option **L15** cannot be combined with the following options:

- **L07** (dv/dt filter compact plus VPL)
- **L08** (motor reactor)
- **L10** (dv/dt filter plus VPL)
- **M78** (motor connection from above)

L19

Connection for external auxiliary equipment

An outgoing feeder fused with max. 10 A for external auxiliary equipment (for example, separately driven motor fan).

The voltage is tapped at the converter input upstream of the main contactor / circuit breaker and, therefore, has the same level as the supply voltage.

The outgoing feeder can be switched inside the drive converter or externally.

Terminal -X155:	Meaning	Range
1	L1	380 ... 690 V AC
2	L2	380 ... 690 V AC
3	L3	380 ... 690 V AC
11	Contactor control	230 V AC
12	Contactor control	230 V AC
13	Feedback signal, circuit breaker	230 V AC/0.5 A; 24 V DC/2 A
14	Feedback signal, circuit breaker	230 V AC/0.5 A; 24 V DC/2 A
15	Feedback signal, contactor	230 V AC/6 A
16	Feedback signal, contactor	230 V AC/6 A
PE	PE	-

For more information on engineering, see: <https://support.industry.siemens.com/cs/document/104961375>

Options (continued)**L21****Surge suppression**

In ungrounded IT systems, the line voltage is not permanently connected to the ground potential because of the missing ground connection of the supply network. Therefore, when a ground fault occurs during operation, a voltage against ground increased by a factor of 2 can occur. For this reason, it is recommended that a surge suppression against ground be installed for operation on IT systems. The surge suppression option includes the installation of line-side surge arresters and upstream fuses for each system phase. The signaling contacts for monitoring the surge arresters are connected in series and connected to a customer interface.

Note:

Option **L21** does not include the components required to install an insulation monitor for the IT system. An insulation monitor should always be ordered separately as option **L87** when the supplying IT system is not monitored at another position (e.g. at the transformer outgoing feeder). Only one insulation monitor can ever be used within the same electrically connected network.

Option **L21** also does not include removal in the factory of the metal bracket that makes the connection to ground of the radio interference suppression filter installed as standard. The metal bracket should therefore be removed during installation or commissioning of the converter if the device is to be operated on an ungrounded IT system.

L26**Main switch incl. fuses or circuit breakers**

Up to 800 A a switch disconnecter with fuses is available as the main switch. For currents greater than 800 A, a circuit breaker provided as standard is used to isolate the drive system from the line supply. The circuit breaker is controlled and supplied within the converter.

Terminal -X50:	Meaning
1	Checkback contact (NO contact) Main breaker/circuit breaker closed
2	Checkback contact (NC contact) Main breaker/circuit breaker closed
3	Common potential

L40**Line filter monitoring**

With option **L40**, the filter in the Active Interface Module is monitored for effectiveness against harmonic effects on the system.

The capacitance of the filter capacitors of the integrated filter is continuously calculated and compared with the installed nominal capacitance by measuring the current and voltage in the Active Interface Module. If the calculated capacity deviates by more than the set tolerance, an alarm is triggered.

L45**EMERGENCY OFF pushbutton, installed in the cabinet door**

The option **L45** only includes the EMERGENCY OFF pushbutton which is fitted with a protective collar in the cabinet door of the converter. The contacts of the pushbutton are brought out and connected to a terminal block.

The EMERGENCY OFF and/or EMERGENCY STOP functions of Category 0 or 1 can be activated in conjunction with options **L57**, **L59**, and **L60**.

Terminal -X120:	Meaning
1	Checkback contact of the EMERGENCY OFF pushbutton in the cabinet door
2	Checkback contact of the EMERGENCY OFF pushbutton in the cabinet door
3	Checkback contact of the EMERGENCY OFF pushbutton in the cabinet door ¹⁾
4	Checkback contact of the EMERGENCY OFF pushbutton in the cabinet door ¹⁾

Notice:

By pressing the EMERGENCY OFF pushbutton, the motor is stopped either uncontrolled or controlled depending on the selected stop Category 0 or 1, and the main voltage disconnected from the motor, in compliance with IEC 60204-1 (VDE 0113). Auxiliary voltages such as the supply for an external fan or anti-condensation heating may still be present. Certain areas within the converter also remain live (under voltage), such as the control or auxiliary equipment. If complete disconnection of all voltages is required, the EMERGENCY OFF pushbutton must be incorporated into a protective system to be implemented by the customer. For this purpose, an NC contact is provided at terminal -X120.

L50**Cabinet lighting with service socket**

With option **L50**, cabinet lighting is included with an additional service socket for a SCHUKO connector (connector type F) according to CEE 7/4. The power supply for the cabinet lighting and the service socket is external and must be fuse-protected for max. 10 A.

The cabinet lighting consists of an LED hand lamp with On/Off switch and with magnetic fasteners with an approx. 3 m long connecting cable. The lamp is factory-positioned in the cabinet door at a defined marking, and the connecting cable is wound on the associated mount.

L55**Anti-condensation heating for cabinet**

The anti-condensation heating is recommended at low ambient temperatures and high levels of humidity to prevent condensation. A 100 W cabinet heater is installed in each cabinet section (two heaters are installed per cabinet with cabinet section widths of between 800 mm and 1200 mm).

The power supply for the anti-condensation heating (110 V to 230 V AC, at terminal block -X240) must be provided externally and fused with max. 16 A.

Terminal -X240:	Meaning
1	L1 (110 ... 230 V AC)
2	N
3	PE

¹⁾ For option **L57** to **L60** is preassigned in the converter.

SINAMICS S150 Converter Cabinet Units

Description of the options

Options (continued)

L57 **EMERGENCY OFF Category 0, 230 V AC or 24 V DC**

EMERGENCY OFF Category 0 for uncontrolled stopping according to EN 60204-1.

The function includes disconnecting the voltage at the converter by means of the line contactor and bypassing the microprocessor controller using a safety combination according to EN 60204-1. The motor then coasts down. When delivered, the pushbutton circuit is preset to 230 V AC. Jumpers must be appropriately set when using 24 V DC.

Terminal -X120:	Meaning
7	Loop in the EMERGENCY OFF pushbutton from the plant side; remove jumper 7-8!
8	Loop in the EMERGENCY OFF pushbutton from the plant side; remove jumper 7-8!
15	"ON" for monitored start; remove jumper 15-16!
16	"ON" for monitored start; remove jumper 15-16!
17	Checkback signal, "Safety combination has tripped"
18	Checkback signal, "Safety combination has tripped"

L59 **EMERGENCY STOP Category 1, 230 V AC**

EMERGENCY STOP Category 1 for controlled stopping according to EN 60204-1.

The function stops the drive using a fast stop along a down ramp that is parameterized by the user. The voltage is then disconnected as described for EMERGENCY OFF Category 0 (option **L57**). The pushbutton circuit is operated at 230 V AC.

In order to maintain the specified stopping times, it may be necessary to use a braking unit.

Terminal -X120:	Meaning
7	Loop in the EMERGENCY OFF pushbutton from the plant side; remove jumper 7-8!
8	Loop in the EMERGENCY OFF pushbutton from the plant side; remove jumper 7-8!
15	"ON" for manual start; remove jumper 15-16!
16	"ON" for manual start; remove jumper 15-16!
17	Checkback signal, "Safety combination has tripped"
18	Checkback signal, "Safety combination has tripped"

L60 **EMERGENCY STOP Category 1, 24 V DC**

EMERGENCY STOP Category 1 for controlled stopping according to EN 60204-1.

The function stops the drive using a fast stop along a down ramp that is parameterized by the user. The voltage is then disconnected as described for EMERGENCY OFF Category 0 (option **L57**). The pushbutton circuit is operated at 24 V DC.

In order to maintain the specified stopping times, it may be necessary to use a braking unit.

Terminal -X120:	Meaning
7	Loop in the EMERGENCY OFF pushbutton from the plant side; remove jumper 7-8!
8	Loop in the EMERGENCY OFF pushbutton from the plant side; remove jumper 7-8!
15	"ON" for manual start; remove jumper 15-16!
16	"ON" for manual start; remove jumper 15-16!
17	Checkback signal, "Safety combination has tripped"
18	Checkback signal, "Safety combination has tripped"

L61, L62, L64, L65 **Braking units**

Braking units may be required for drives in which motors might operate in generator mode, but have no facility for feeding energy back into the supply system.

The braking unit comprises two components:

- A Braking Module, which can be installed in the air discharge of the chassis format power units
- A braking resistor to be mounted externally (degree of protection IP20)

The braking unit functions as an autonomous unit, and does not require an external power supply. During the braking process, the kinetic energy is converted into heat in the externally mounted braking resistor.

A max. cable length of 100 m is permissible between the Braking Module and the braking resistor. This allows the braking resistor to be mounted externally so that heat losses can be dissipated outside the converter enclosure. The braking resistor is connected directly to the terminal -X5 of the converter.

Options (continued)

The following braking units are available for SINAMICS S150 converter cabinet units:

Option	SINAMICS S150 converter Type rating kW	Braking Module		
		Rated power P_{DB} kW	Rated power P_{20} kW	Peak power P_{15} kW
380 ... 480 V 3 AC				
L61	110 ... 132	25	100	125
L62	160 ... 800	50	200	250
500 ... 600 V 3 AC				
L64	75 ... 132	25	100	125
L65	160 ... 1200	50	200	250
660 ... 690 V 3 AC				
L61	75 ... 132	25	100	125
L62	160 ... 1200	50	200	250

P_{DB} = Rated power (continuous braking power)

$P_{20} = 4 \times P_{DB}$: 20 s power referred to a braking interval of 90 s

$P_{15} = 5 \times P_{DB}$: 15 s power referred to a braking interval of 90 s

If more braking power is required than provided by the braking units listed here, then braking units may be connected in parallel for higher converter outputs (on request). In this case, a Braking Module is assigned to each braking resistor.

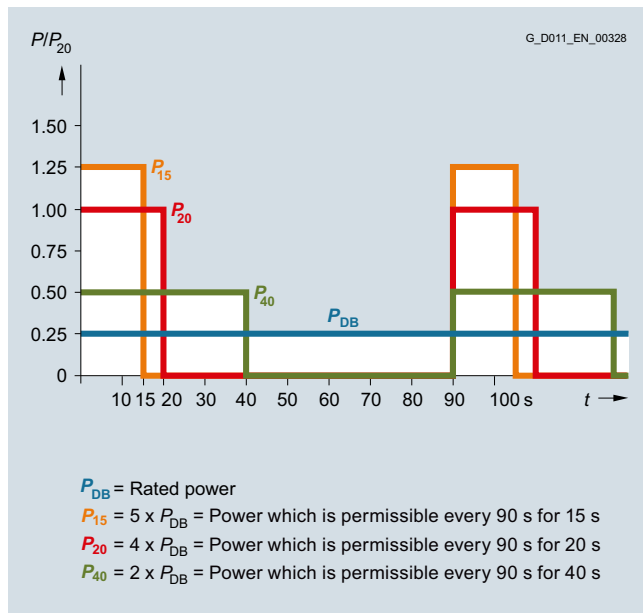

Load diagram for Braking Modules and braking resistors

Additional notes about possible duty cycles of the braking resistors and other engineering notes are included in the SINAMICS Low Voltage Configuration Manual.

L83**Thermistor motor protection device (alarm)**

Thermistor motor protection device for PTC thermistors (PTC resistors, type A) for alarm. The thermistor motor protection device is supplied with power and evaluated internally in the converter.

Terminal	Meaning
-B127:	
T1	Sensor circuit connection
T2	Sensor circuit connection

L84**Thermistor motor protection device (trip)**

Thermistor motor protection device for PTC thermistors (PTC resistors, type A) for trip. The thermistor motor protection device is supplied with power and evaluated internally in the converter.

Terminal	Meaning
-B125:	
T1	Sensor circuit connection
T2	Sensor circuit connection

L86**Pt100 evaluation unit**

The Pt100 evaluation unit can monitor up to six sensors. The sensors can be connected in a two or three-wire system. The limit values can be freely programmed for each channel.

In the factory setting, the measuring channels are subdivided into two groups, each with 3 channels. With motors, for example, this means that three Pt100s in the stator windings and two Pt100s in the motor bearings can be monitored. Unused channels can be hidden via parameters.

The output relays are integrated into the internal fault and shutdown sequence of the converter.

L87**Insulation monitoring**

An insulation monitor must be used if the converter is connected to an ungrounded line supply. The device monitors the entire galvanically coupled circuit for insulation faults.

An alarm is output in the event of a fault.

Notice:

Only **one** insulation monitor can be used in each galvanically coupled network.

As there are different response strategies when a ground fault occurs in an ungrounded system, output relays of the insulation monitor are provided for integration in a plant-side control. The customer can also choose to integrate the outputs into the converter monitoring system.

SINAMICS S150 Converter Cabinet Units

Description of the options

Options (continued)

M06

Base 100 mm high, RAL 7022

The additional cabinet base allows larger bending radii for cables (cable inlet from below) and enables them to be routed within the cabinet base.

The cabinet base is supplied in RAL 7022 as standard. A special paint finish is not available for the base. It is delivered completely assembled with the cabinet. The height of the operator panel changes accordingly.

M07

Cable marshalling space 200 mm high, RAL 7035

The cable marshalling space is made of strong sheet steel and allows cables to be connected more flexibly (entry from below). It also allows routing of cables within the marshalling compartment. It is delivered completely assembled with the cabinet. The height of the operator panel changes accordingly.

Notice:

The cable compartment is painted as standard with RAL 7035. If a special color is requested for the cabinet (option **Y09**), the cable marshalling space is also painted in this color.

M13

Line connection from above

The control cabinet is provided with an additional roof section to allow a line connection from above. The connection lugs for the power cables, the clamping bar for mechanically securing the cables, an EMC shield bus, and a PE busbar are located within this roof section.

This increases the cabinet height by 405 mm. The busbars for the connection from above are delivered completely pre-installed. For transport reasons, the roof sections are delivered separately and must be fitted on site. Crane transport assemblies (option **M90**) can still be used. However, they must be removed on site before the roof sections can be installed. Use of rope spreaders should be considered in the case of small crane hook heights.

An undrilled aluminum mounting plate (5 mm thick) is provided in the roof section for feeding in the cables. Depending on the number of cables and the cross-sections used, holes for attaching cable glands for feeding in the cables must be drilled in this mounting plate on site.

Note:

The control cables are still connected from below. Option **M13** eliminates the lugs, provided as standard, to connect the line supply from below.

The degree of protection of the roof sections is IP21. In combination with options **M23**, **M43** and **M54**, additional plastic ventilation grilles and filter elements are provided.

Notice:

The roof sections are painted in RAL 7035 as standard. If a special color is requested for the cabinet (option **Y09**), the roof section is also painted in this color. Ventilation grilles used with degrees of protection IP23 and IP54 have color RAL 7035 and cannot be painted.

The covers provided with option **M60** are also included in the scope of supply.

M21

Degree of protection IP21

Cabinet version in IP20, but with additional top cover or canopy. This increases the cabinet height by 250 mm.

For transport reasons, the top covers or canopies are delivered separately and must be fitted on site.

Notice:

The top covers or canopies are painted in RAL 7035 as standard. If a special color is requested for the cabinet (option **Y09**), the roof sections or drip protection panel are also painted in this color.

M23

Degree of protection IP23

Converter cabinet units with degree of protection IP23 are supplied with additional roof sections as well as plastic ventilation grilles and a filter medium in the air inlet and outlet. This increases the cabinet height by 400 mm. The covers provided with option **M60** are also included in the scope of supply. The filter medium must be maintained according to the local environmental conditions.

For transport reasons, the roof sections are delivered separately and must be fitted on site.

Notice:

The roof sections are painted in RAL 7035 as standard. If a special color is requested for the cabinet (option **Y09**), the roof section is also painted in this color. The molded plastic parts (e.g. ventilation grilles) are in RAL 7035 and cannot be painted.

M43

Degree of protection IP43

Converter cabinet units with IP43 degree of protection are supplied with additional roof sections as well as plastic ventilation grilles and a wire mesh in the air inlet and outlet. This increases the cabinet height by 400 mm. The covers provided with option **M60** are also included in the scope of supply. They are an integral component of the internal cabinet air guidance system and are adapted accordingly.

For transport reasons, the roof sections are delivered separately and must be fitted on site.

Notice:

The roof sections are painted in RAL 7035 as standard. If a special color is requested for the cabinet (option **Y09**), the roof section is also painted in this color. The molded plastic parts (e.g. ventilation grilles) are in RAL 7035 and cannot be painted.

Options (continued)**M54****Degree of protection IP54**

Converter cabinet units with IP54 degree of protection are supplied with additional roof sections as well as plastic ventilation grilles and a filter medium in the air inlet and outlet. This increases the cabinet height by 400 mm. The covers provided with option **M60** are also included in the scope of supply. They are an integral component of the internal cabinet air guidance system and are adapted accordingly. The filters must be maintained according to the local environmental conditions.

For transport reasons, the roof sections are delivered separately and must be fitted on site.

Notice:

- The roof sections are painted in RAL 7035 as standard. If a special color is requested for the cabinet (option **Y09**), the roof section is also painted in this color. The molded plastic parts (e.g. ventilation grilles) are in RAL 7035 and cannot be painted.
- For units with IP54 degree of protection, it is important to observe the derating factor for output currents in relation to ambient temperature and installation altitude.

M60**Additional touch protection**

The converter cabinet units are designed as standard according to BGV A3. Option **M60** provides additional covers (outside arm's reach) in the vicinity of the AC busbars and above the power unit (can only be selected as an option with converters up to 250 kW in the 400 V range and with converters up to 315 kW in the 690 V range with degrees of protection IP20 and IP21; otherwise supplied as standard).

M66**Marine version**

For compliance with the requirements of the classification institutes:

- Lloyds Register
- American Bureau of Shipping
- Germanischer Lloyd
- Bureau Veritas
- Det Norske Veritas
- China Classification Society

This option includes a strengthened mechanical version of the cabinet, handles (handrail) below the operator panel and mechanical locking of the cabinet doors. The cabinet has degree of protection IP23 (option **M23**) and includes a cabinet anti-condensation heater (option **L55**). To secure the converter to the ship's hull, a welding frame (5 mm high) is supplied separately.

Note:

Combination with options **M21**, **M23**, and **L55** is not possible. Individual certification is additionally required if the converter is used for a safety-related drive on the ship (see options **E11** to **E71**).

M70**EMC shield bus (cable connection from below)**

The EMC shield bus is used to connect shielded line and motor supply cables. With the options **M13** and **M78**, the EMC shielding busbar is already included as standard for the connection busbars underneath the roof section.

M78**Motor connection from above**

The control cabinet is provided with an additional roof section for a motor connection from above. The connection lugs for the power cables, the clamping bar for mechanically securing the cables, an EMC shield bus, and a PE busbar are located within this roof section.

This increases the cabinet height by 405 mm. The busbars for the connection from above are delivered completely pre-installed. For transport reasons, the roof sections are delivered separately and must be fitted on site. Crane transport assemblies (option **M90**) can still be used. However, they must be removed on site before the roof sections can be installed. Use of rope spreaders should be considered in the case of small crane hook heights.

An undrilled aluminum mounting plate (5 mm thick) is provided in the roof section for feeding in the cables. Depending on the number of cables and the cross-sections used, holes for attaching cable glands for feeding in the cables must be drilled in this mounting plate on site.

Note:

The control cables are still connected from below. Option **M78** eliminates the lugs, provided as standard, to connect the motor from below.

The degree of protection of the roof sections is IP21. In combination with options **M23**, **M43** and **M54**, additional plastic ventilation grilles and filter elements are provided.

Notice:

The roof sections are painted in RAL 7035 as standard. If a special color is requested for the cabinet (option **Y09**), the roof section is also painted in this color. Ventilation grilles used with IP23, IP43 and IP54 degrees of protection are in RAL 7035 and cannot be painted.

The covers provided with option **M60** are also included in the scope of supply.

Note:

Option **M78** cannot be combined with the following options:

- **L07** (dv/dt filter compact plus VPL)
- **L08** (motor reactor)
- **L10** (dv/dt filter plus VPL)
- **L15** (sine-wave filter)

SINAMICS S150 Converter Cabinet Units

Description of the options

Options (continued)

M90

Crane transport assembly (top-mounted)

For single cabinets up to a width of 600 mm, the crane transport assembly consists of transport eyebolts. For cabinet widths of 800 mm and wider, transport rails are used.

M91

Marking of all control cable conductor ends

When this option is selected, all control cables or conductor ends (including all customer-specific options) are labeled throughout the cabinet.

T58, T60, T80, T83, T85, T91

Rating plate data

The type plate is provided in English/German as standard. A rating plate in another language combination can be selected by specifying the following option order codes.

Option	Rating plate language
T58	English/French
T60	English/Spanish
T80	English/Italian
T83	English/Portuguese (Brazil)
T85	English/Russian
T91	English/Chinese

Y09

Special cabinet paint finish

The converter cabinet units are delivered in RAL 7035 as standard. The special paint finish must be specified in plain text when ordering. All RAL colors which are available as powder coatings can be selected.

Notice:

If options such as cable marshaling space (option **M07**), top or drip protection covers (option **M21**), roof sections (options **M23/M43/M54**) or cable connection from above (options **M13/M78**) are ordered for the converter cabinet units, they will also be supplied in the paint finish stated in the order. The molded plastic parts (e.g. ventilation grilles) are in RAL 7035 and cannot be painted.

Y31

One-line label for system identification, 40 × 80 mm

Resopal labels (white with black lettering) for identifying the control cabinets are available. The labels are stuck to the cabinet door.

Dimensions H × W: 40 × 80 mm

The text must be specified in plain text when ordering.

Field 1: Max. 9 characters, font size 10 mm

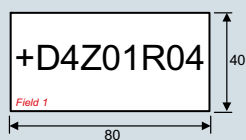

Y32

Two-line label for system identification, 40 × 180 mm

Resopal labels (white with black lettering) for identifying the control cabinets are available. The labels are stuck to the cabinet door.

Dimensions H × W: 40 × 180 mm

The text must be specified in plain text when ordering.

Field 1: Max. 9 characters, font size 10 mm

Field 2: Max. 9 characters, font size 10 mm

Field 3: Max. 20 characters, font size 10 mm

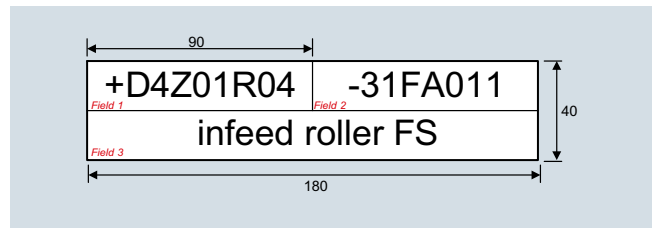

Y33

Four-line label for system identification, 40 × 180 mm

Resopal labels (white with black lettering) for identifying the control cabinets are available. The labels are stuck to the cabinet door.

Dimensions H × W: 40 × 180 mm

The text must be specified in plain text when ordering.

Field 1: Max. 9 characters, font size 10 mm

Field 2: Max. 20 characters, font size 6 mm

Field 3: Max. 20 characters, font size 6 mm

Field 4: Max. 20 characters, font size 6 mm

Field 5: Max. 20 characters, font size 6 mm

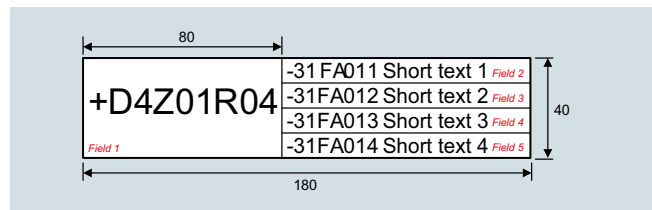

Overview

The fuses specified below are the recommended types for protecting the unit on the low-voltage distribution panel. If option **L26** was selected for SINAMICS S150 with rated input currents <800 A, then the semiconductor protection is already integrated in the unit. For units of >800 A, this function is performed by the circuit breaker provided as standard.

In this case, a 3NA fuse can be used in the distribution board. If option **L26** has not been selected for units <800 A, we strongly advise that 3NE fuses are used ¹⁾.

Catalog LV 10 contains additional information on the listed fuses.

Type rating at 400 V or 690 V		SINAMICS S150 converter 6SL3710-...	Cable protection fuse in systems with a fuse switch disconnecter			Cable protection fuse (incl. semiconductor protection) in systems without fuse switch disconnecter		
At I_L , 50 Hz 400 V, 500 V or 690 V	At I_L , 60 Hz 460 V or 575 V		Article No.	Rated current A	Size according to DIN 43620-1	Article No.	Rated current A	Size according to DIN 43620-1
kW	hp							
Line voltage 380 ... 480 V 3 AC								
110	150	7LE32-1AA3	3NA3252	315	2	3NE1230-2	315	1
132	200	7LE32-6AA3	3NA3254	355	2	3NE1331-2	350	2
160	250	7LE33-1AA3	3NA3365	500	3	3NE1334-2	500	2
200	300	7LE33-8AA3	3NA3365	500	3	3NE1334-2	500	2
250	400	7LE35-0AA3	3NA3372	630	3	3NE1436-2	630	3
315	500	7LE36-1AA3	3NA3475	800	4	3NE1438-2	800	3
400	600	7LE37-5AA3	3NA3475	800	4	3NE1448-2	850	3
450	700	7LE38-4AA3	–	–	–	Circuit breaker included as standard		
560	800	7LE41-0AA3	–	–	–	Circuit breaker included as standard		
710	1000	7LE41-2AA3	–	–	–	Circuit breaker included as standard		
800	1000	7LE41-4AA3	–	–	–	Circuit breaker included as standard		
Line voltage 500 ... 690 V 3 AC								
75	75	7LG28-5AA3	3NA3132-6	125	1	3NE1022-2	125	00
90	75	7LG31-0AA3	3NA3132-6	125	1	3NE1022-2	125	00
110	100	7LG31-2AA3	3NA3136-6	160	1	3NE1224-2	160	1
132	150	7LG31-5AA3	3NA3240-6	200	2	3NE1225-2	200	1
160	150	7LG31-8AA3	3NA3244-6	250	2	3NE1227-2	250	1
200	200	7LG32-2AA3	3NA3252-6	315	2	3NE1230-2	315	1
250	250	7LG32-6AA3	3NA3354-6	355	3	3NE1331-2	350	2
315	300	7LG33-3AA3	3NA3365-6	500	3	3NE1334-2	500	2
400	400	7LG34-1AA3	3NA3365-6	500	3	3NE1334-2	500	2
450	450	7LG34-7AA3	3NA3352-6	2 × 315	2	3NE1435-2	560	3
560	600	7LG35-8AA3	3NA3354-6	2 × 355	3	3NE1447-2	670	3
710	700	7LG37-4AA3	3NA3365-6	2 × 500	3	3NE1448-2	850	3
800	800	7LG38-1AA3	–	–	–	Circuit breaker included as standard		
900	900	7LG38-8AA3	–	–	–	Circuit breaker included as standard		
1000	1000	7LG41-0AA3	–	–	–	Circuit breaker included as standard		
1200	1250	7LG41-3AA3	–	–	–	Circuit breaker included as standard		

¹⁾ The double function fuses (3NE1.) with duty class gS for cable and semiconductor protection are recommended to protect the converter. These fuses are specially adapted to the requirements of the semiconductors in the input rectifier.

- Super fast
- Lower arc voltage
- Improved current limiting (lower let-through values).

SINAMICS S150 Converter Cabinet Units

Cable cross-sections and connections

Overview

The following tables list the recommended and maximum connectable line and motor-side cable cross sections and connections for a single connection.

The recommended cross-sections are based on the specified fuses. They are valid for a 3-conductor copper cable routed horizontally in air with PVC insulation and a permissible conductor temperature of 70 °C (e.g. Protodur NYY or NYCWY) at an ambi-

ent temperature of 40 °C and individual routing. In conditions (cable routing, cable bundling, ambient temperature) that deviate from this the corresponding correction factors according to IEC 60364-5-52 must be considered.

For additional information, please refer to the [SINAMICS Low Voltage Engineering Manual](#).

Type rating at 400 V or 690 V	SINAMICS S150 converter cabinet unit	Line supply connection			Motor connection			Cabinet grounding	
		Recommended cross-section ¹⁾	Maximum conductor cross-section	M12 fixing screw (Number of holes)	Recommended cross-section ¹⁾	Maximum conductor cross-section	M12 fixing screw (Number of holes)	M12 fixing screw (Number of holes)	Remarks
kW	6SL3710-...	mm ²	mm ²		mm ²	mm ²			
380 ... 480 V 3 AC									
110	7LE32-1AA3	2 × 70	4 × 240	(2)	2 × 50	2 × 150	(2)	(2)	
132	7LE32-6AA3	2 × 95	4 × 240	(2)	2 × 70	2 × 150	(2)	(2)	
160	7LE33-1AA3	2 × 120	4 × 240	(2)	2 × 95	2 × 150	(2)	(2)	
200	7LE33-8AA3	2 × 120	4 × 240	(2)	2 × 95	2 × 150	(2)	(2)	
250	7LE35-0AA3	2 × 185	4 × 240	(2)	2 × 150	2 × 240	(2)	(2)	
315	7LE36-1AA3	2 × 240	4 × 240	(2)	2 × 185	4 × 240	(2)	(2)	
400	7LE37-5AA3	3 × 185	4 × 240	(2)	2 × 240	4 × 240	(2)	(10)	Cu bar
450	7LE38-4AA3	4 × 150	8 × 240	(4)	3 × 185	4 × 240	(2)	(16)	Cu bar
560	7LE41-0AA3	4 × 185	8 × 240	(4)	4 × 185	6 × 240	(3)	(18)	Cu bar
710	7LE41-2AA3	4 × 240	8 × 240	(4)	4 × 240	6 × 240	(3)	(18)	Cu bar
800	7LE41-4AA3	6 × 185	8 × 240	(4)	6 × 185	6 × 240	(3)	(18)	Cu bar
500 ... 690 V 3 AC									
75	7LG28-5AA3	50	4 × 240	(2)	35	2 × 70	(2)	(2)	
90	7LG31-0AA3	50	4 × 240	(2)	50	2 × 150	(2)	(2)	
110	7LG31-2AA3	70	4 × 240	(2)	70	2 × 150	(2)	(2)	
132	7LG31-5AA3	95	4 × 240	(2)	70	2 × 150	(2)	(2)	
160	7LG31-8AA3	120	4 × 240	(2)	95	2 × 150	(2)	(2)	
200	7LG32-2AA3	2 × 70	4 × 240	(2)	120	2 × 150	(2)	(2)	
250	7LG32-6AA3	2 × 95	4 × 240	(2)	2 × 70	2 × 185	(2)	(2)	
315	7LG33-3AA3	2 × 120	4 × 240	(2)	2 × 95	2 × 240	(2)	(2)	
400	7LG34-1AA3	2 × 185	4 × 240	(2)	2 × 120	4 × 240	(2)	(2)	
450	7LG34-7AA3	2 × 185	4 × 240	(2)	2 × 150	4 × 240	(2)	(2)	
560	7LG35-8AA3	2 × 240	4 × 240	(2)	2 × 185	4 × 240	(2)	(2)	
710	7LG37-4AA3	3 × 185	8 × 240	(4)	3 × 150	6 × 240	(3)	(18)	Cu bar
800	7LG38-1AA3	4 × 150	8 × 240	(4)	3 × 185	6 × 240	(3)	(18)	Cu bar
900	7LG38-8AA3	4 × 150	8 × 240	(4)	4 × 150	6 × 240	(3)	(18)	Cu bar
1000	7LG41-0AA3	4 × 185	8 × 240	(4)	4 × 185	6 × 240	(3)	(18)	Cu bar
1200	7LG41-3AA3	4 × 240	8 × 240	(4)	4 × 240	6 × 240	(3)	(18)	Cu bar

¹⁾ The recommendations for the North American market in AWG or MCM must be taken from the appropriate NEC (National Electrical Code) and CEC (Canadian Electrical Code) standards.

Overview (continued)**Cable cross-sections for line and motor connection**

It is generally recommended to use shielded 3-conductor three-phase cables between the converter and motor – and for higher power ratings, symmetrical cables where possible. If required, several of these cables can be connected in parallel. There are two main reasons for this:

- Only then can the high IP55 degree of protection at the motor terminal box be easily achieved. The reason for this is that cables are routed into the terminal box through glands, and the number of possible glands is restricted by the terminal box geometry. Therefore single cables are less suitable.
- With symmetrical 3-wire three-phase cables, the summed ampere-turns over the cable outer diameter are equal to zero. They can easily be routed in conductive, metal cable ducts or racks without any significant currents (ground current or leakage current) being induced in these conductive, metal connections. The danger of induced leakage currents and thus of increased cable sheath losses is significantly higher with single-conductor cables.

The cable cross-section required depends on the current being conducted in the cable. The permissible current load capability of cables is defined, for example in IEC 60364-5-52. It depends partly on the ambient conditions such as temperature, but also on the routing method. It should be taken into account whether cables are individually routed with relatively good cooling, or whether several cables are routed together; in this case, cable ventilation is significantly poorer, which can therefore result in higher cable temperatures. Regarding this topic, reference is made to the corresponding correction factors for these secondary conditions in IEC 60364-5-52.

For 3-conductor copper and aluminum cables with PVC insulation and a permissible conductor temperature of 70 °C (e.g. Protodur NYY or NYCWY), as well as an ambient temperature of 40 °C, the cross-sections can be determined from the following table, which is based on IEC 60364-5-52.

Cross-section of 3-conductor cable mm ²	Copper cable		Aluminum cable	
	Individual routing A	Several cables next to one another ¹⁾ A	Individual routing A	Several cables next to one another ¹⁾ A
3 × 2.5	22	17	17	13
3 × 4.0	30	23	23	18
3 × 6.0	37	29	29	22
3 × 10	52	41	40	31
3 × 16	70	54	53	41
3 × 25	88	69	68	53
3 × 35	110	86	84	65
3 × 50	133	104	102	79
3 × 70	171	133	131	102
3 × 95	207	162	159	124
3 × 120	240	187	184	144
3 × 150	278	216	213	166
3 × 185	317	247	244	190
3 × 240	374	292	287	224

Current-carrying capacity according to IEC 60364-5-52 at 40 °C

¹⁾ A maximum of 9 cables may be routed directly next to one another horizontally on a cable tray.

Cables must be connected in parallel for higher currents.

Note:

The recommendations for the North American market in AWG or MCM must be taken from the appropriate NEC (National Electrical Code) and CEC (Canadian Electrical Code) standards.

Grounding and protective conductor cross-section

The protective conductor must be dimensioned taking into account the following data:

- In the case of a ground fault, no impermissibly high contact voltages resulting from voltage drops on the PE conductor caused by the ground fault current may occur (< 50 V AC or < 120 V DC, IEC 61800-5-1, IEC 60364, IEC 60543).
- The protective conductor must not be excessively loaded by any ground fault current it carries.
- If it is possible for continuous currents to flow through the protective conductor when a fault occurs, then the protective conductor cross-section must be dimensioned for this continuous current.
- The protective conductor cross-section must be selected according to EN 60204-1, EN 60439-1, IEC 60364.

Cross-section, line conductor mm ²	Minimum cross-section, external protective conductor mm ²
up to 16	Minimum cross-section of line conductor
16 ... 35	16
from 35	Minimum half the cross-section of line conductor

Note:

The recommendations for the North American market in AWG or MCM must be taken from the appropriate NEC (National Electrical Code) and CEC (Canadian Electrical Code) standards.

- Switchgear and motors are usually grounded separately via a local grounding electrode. With this constellation, the ground fault current flows via the parallel ground connections and is divided. In spite of the relatively small protective conductor cross sections used in accordance with the table above, no inadmissible touch voltages occur with this grounding system. However, from experience gained with different grounding constellations, we recommend that the ground cable from the motor return directly to the converter. For EMC reasons and to avoid bearing currents, for large power ratings, it is preferable to use symmetrical 3-conductor, three-phase cables instead of four-conductor cables. For 3-conductor cables, the protective or PE conductor must be routed separately or arranged symmetrically in the motor cable. Symmetry of the PE conductor is achieved using a conductor surrounding all phase conductors or using a cable with a symmetrical arrangement of the three phase conductors and three ground conductors.

[For additional information, please refer to the SINAMICS Low Voltage Engineering Manual.](#)

- Through their high-speed control, the converters limit the load current (motor and ground fault currents) to an rms value corresponding to the rated current. As a result of this fact, we recommend that the cross-section of the protective conductor to ground the cabinets is the same as for the outer (main) conductor.

SINAMICS S150 Converter Cabinet Units

Supplementary system components

Mounting device for power blocks

Overview



The mounting device is used for installing and removing the power blocks.

The mounting device is a mounting aid. It is placed in front of the module and attached to the module. The telescopic rails allow the device to be adjusted to the installation height of the power blocks.

Once the mechanical and electrical connections have been released, the power block can be removed from the module.

The power block is guided and supported by the guide rails on the handling device.

Selection and ordering data

Description	Article No.
Mounting device for installing and removing power blocks	6SL3766-1FA00-0AA0

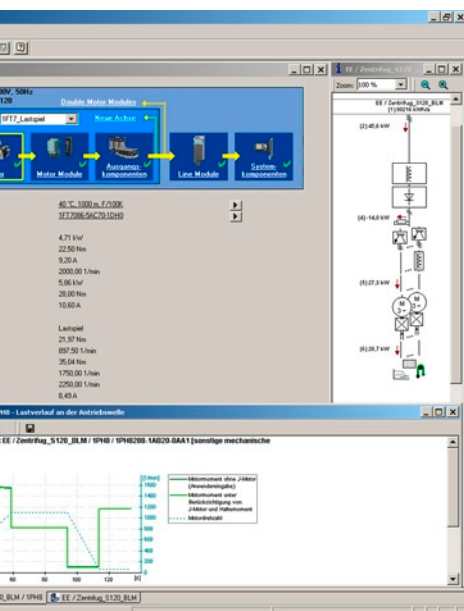

6/2	SinaSave Energy Efficiency Tool
6/3	Drive Technology Configurator
6/4	SIZER for Siemens Drives engineering tool
6/5	SIZER WEB ENGINEERING
6/6	STARTER commissioning tool
6/8	SINAMICS Drive Control Chart (SINAMICS DCC)
6/9	Drive ES engineering software
6/11	Configuration with EPLAN
6/13	General procedure when engineering
6/14	Engineering Manual

Security information

Siemens provides products and solutions with industrial security functions that support the secure operation of plants, solutions, machines, equipment and/or networks. They are important components in a holistic industrial security concept. With this in mind, Siemens' products and solutions undergo continuous development. Siemens recommends strongly that you regularly check for product updates.

For the secure operation of Siemens products and solutions, it is necessary to take suitable preventive action (e.g. cell protection concept) and integrate each component into a holistic, state-of-the-art industrial security concept. Thirdparty products that may be in use should also be considered. For more information about industrial security, visit

www.siemens.com/industrialsecurity

To stay informed about product updates as they occur, sign up for a product-specific newsletter. For more information, visit

<https://support.industry.siemens.com>

Tools and Engineering

SinaSave Energy Efficiency Tool

Overview

The SinaSave Energy Efficiency Tool calculates potential savings and payback periods on the basis of your specific operating conditions, providing valuable decision guidance with respect to investment in energy-efficient technologies.

The drive systems to be compared and the relevant parameters of the drive components are displayed graphically with SinaSave version 6.0 and higher. The wide range of options for comparing different control modes and comprehensive product combinations for drive solutions for pump and fan applications are useful additions. The portfolio of products includes SIMOTICS motors and SINAMICS converters as well as SIRIUS switching devices, offering a wide spectrum of possibilities for comparison according to your requirements.



SinaSave offers a wide range of possibilities for comparison:

- Comparison of drive systems for pump and fan applications with
 - Throttle control (fixed speed; motor and switching device)
 - Bypass control (fixed speed; motor and switching device)
 - Speed control (variable speed; motor and converter)
- Comparison and evaluation of products in various energy efficiency classes
- Comparison of Siemens drive systems with third-party drive components



[Access to the SinaSave Energy Efficiency Tool](http://www.automation.siemens.com/sinasave)

SinaSave can be used without registration and without login:
www.automation.siemens.com/sinasave

More information

For more information about the amortization calculator for energy-efficient drive systems, visit www.siemens.com/sinasave

More information about services for energy saving is available on the Internet at www.siemens.com/energysaving

Overview

The Drive Technology Configurator (DT Configurator) helps you to configure the optimum drive technology products for your application – starting with gear units, motors, inverters and the associated options and components and ending with controllers, software licenses and connection technology. Whether with little or detailed knowledge of products: You can easily, quickly and efficiently configure your particular drive using product group preselectors, targeted navigation through selection menus or by entering article numbers directly to select the products.

In addition to all this, comprehensive documentation comprising technical data sheets, 2D/3D dimensional drawings, operating instructions, certificates etc. can be selected in the DT Configurator. The products that you select can be directly ordered by transferring a parts lists to the shopping cart of the Industry Mall.

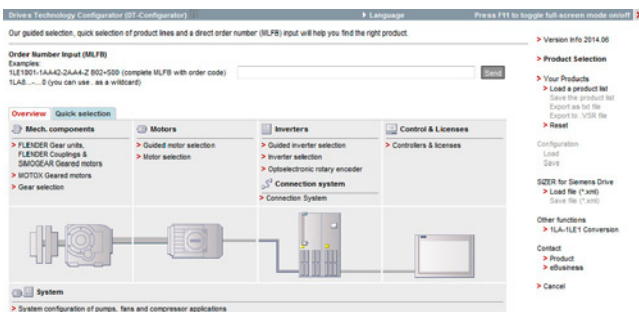

Drive Technology Configurator for efficient drive configuration with the following functions:

- Quick, efficient configuration of drive products and associated components – gear units, motors, inverters, controllers, connection technology
- Configuration of drive systems for pump, fan and compressor applications from 1 kW to 2.6 MW
- Retrievable documentation for configured products and components, such as
 - Data sheets in up to 7 languages in PDF or RTF formats
 - 2D/3D dimensional drawings in various formats
 - Terminal box diagram and terminal connection diagram
 - Operating instructions
 - Certificates
 - Starting calculation for SIMOTICS motors
 - EPLAN macros
- Support for retrofit projects in conjunction with Spares On Web (www.siemens.com/sow)
- Products can be ordered directly through the Siemens Industry Mall

Access to the Drive Technology Configurator

The Drive Technology Configurator can be accessed without registration and login:

www.siemens.com/dt-configurator

Selection and ordering data

Description	Article No.
Interactive Catalog CA 01 on DVD-ROM including Drive Technology Configurator, English	E86060-D4001-A510-D6-7600

More information

[Online access to the Drive Technology Configurator](#)

More information about the Drive Technology Configurator is available on the Internet at www.siemens.com/dtconfigurator

[Offline access to the Drive Technology Configurator in the Interactive Catalog CA 01](#)

In addition, the Drive Technology Configurator is also included in the Interactive Catalog CA 01 on DVD-ROM – the offline version of the Siemens Industry Mall.

The Interactive Catalog CA 01 can be ordered from the relevant Siemens sales office or via the Internet: www.siemens.com/automation/CA01

Tools and Engineering

SIZER for Siemens Drives engineering tool

Overview

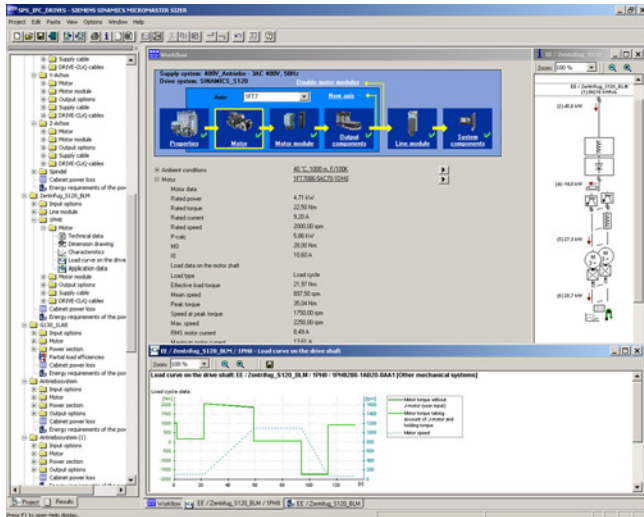

The following drives and controls can be engineered in a user-friendly way using the SIZER for Siemens Drives engineering tool:

- SIMOTICS low-voltage motors, including servogear motors
- SINAMICS low-voltage drive systems
- Motor starters
- SINUMERIK CNC
- SIMOTION Motion Control system
- SIMATIC Technology

It provides support when selecting the technologies involved in the hardware and firmware components required for a drive task. SIZER for Siemens Drives supports the complete configuration of the drive system, from basic single drives to demanding multi-axis applications.

SIZER for Siemens Drives supports all of the configuring steps in a workflow:

- Configuring the power supply
- Designing the motor and gearbox, including calculation of mechanical transmission elements
- Configuring the drive components
- Compiling the required accessories
- Selecting the line-side and motor-side power options, e.g. cables, filters, and reactors

When SIZER for Siemens Drives was being designed, particular importance was placed on a high degree of usability and a universal, function-based approach to the drive application. The extensive user guidance makes using the tool easy. Status information keeps you continually informed about the progress of the configuration process.

The SIZER for Siemens Drives user interface is available in English, French, German and Italian.

The drive configuration is saved in a project. In the project, the components and functions used are displayed in a hierarchical tree structure.

The project view permits the configuration of drive systems and the copying/inserting/modifying of drives already configured.

The configuration process produces the following results:

- A parts list of the required components (export to Excel, use of the Excel data sheet for import to SAP)
- Technical specifications of the system
- Characteristic curves
- Comments on system reactions
- Mounting arrangement of drive and control components and dimension drawings of motors
- Energy requirements of the configured application

These results are displayed in a results tree and can be reused for documentation purposes.

Technological online help is available:

- Detailed technical specifications
- Information about the drive systems and their components
- Decision-making criteria for the selection of components
- Online help in English, French, German, Italian, Chinese and Japanese

System requirements

- PG or PC with Pentium III min. 800 MHz (recommended > 1 GHz)
- 512 MB RAM (1 GB RAM recommended)
- At least 4.1 GB of free hard disk space
- An additional 100 MB of free hard disk space on Windows system drive
- Screen resolution 1024 × 768 pixels (1280 × 1024 pixels recommended)
- Operating system:
 - Windows 7 Professional (32/64 bit)
 - Windows 7 Enterprise (32/64 bit)
 - Windows 7 Ultimate (32/64 bit)
 - Windows 7 Home (32/64 bit)
 - Windows 8.1 Professional (32/64 bit)
 - Windows 8.1 Enterprise (32/64 bit)
- Microsoft Internet Explorer V5.5 SP2

Selection and ordering data

Description	Article No.
SIZER for Siemens Drives engineering tool on DVD-ROM	6SL3070-0AA00-0AG0
English, French, German, Italian	

More information

The SIZER for Siemens Drives engineering tool is available free on the Internet at www.siemens.com/sizer

Overview



SIZER WEB ENGINEERING is used to engineer motors, converters and drive systems in various applications and covering a wide power range starting below 1 kW up to 30 MW and above. Engineering can be performed by entering parameters for the motor, converter or system – as well as entering parameters for your particular application.

You obtain comprehensive technical documentation (e.g. 3D models) including pricing information as result.

Based on an integrated inquiry function, the tool also offers special individual solutions for your drive applications.

SIZER WEB ENGINEERING supports you from inquiry, through the product and drive system engineering, to an individual quotation, provides pricing information and finally transfers the engineered products to the shopping cart of the Industry Mall. The seamless support of the process helps you to save time and increase productivity as all data have to be entered once only. The input data as well as the result can be reused for the inquiry and ordering.

SIZER WEB ENGINEERING is the platform to flexibly engineer your drive tasks and manage your projects in a user-friendly fashion interacting with other tools, namely Drive Technology Configurator and SIZER for Siemens Drives.

Function

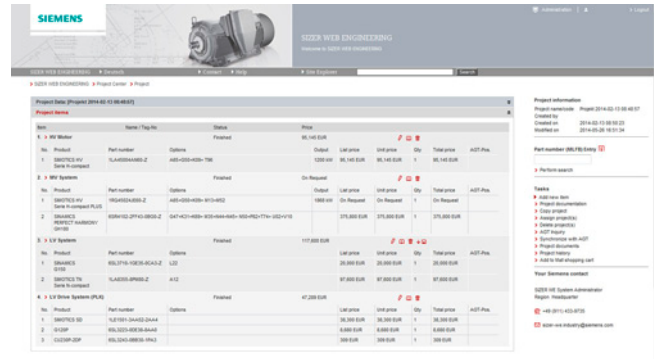

You can quickly find a solution for your drive task with the web-based tool: menu-prompted workflows navigate you through the technical selection and dimensioning of products and drive systems, including the accessories. Based on an integrated inquiry functionality, SIZER WEB ENGINEERING also offers you special customized solutions for applications which cannot be addressed using "Standard Products"; i.e. the focus is on flexibility and customized solutions.

In addition to the products from the low-voltage range, you can also configure high voltage motors, medium voltage systems and DC converters for your projects. Comprehensive documentation, such as data sheets, startup calculations for low-voltage and high-voltage motors, 2D dimensional drawings and 3D CAD models, offer documentation, and a lot more are integrated in the tool.

Access to SIZER WEB ENGINEERING

After successful registration and approval, SIZER WEB ENGINEERING is available at:
www.siemens.com/sizer-we

More information

- Further information on SIZER WEB ENGINEERING is available on the Internet at www.siemens.com/sizer-we
- Home page "Selection and engineering tools": www.siemens.com/engineering-tools

Tools and Engineering

STARTER commissioning tool

Overview

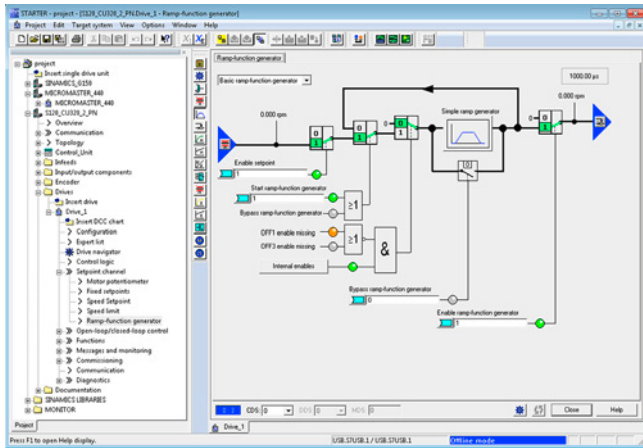

The user-friendly STARTER commissioning tool can be used for:

- Commissioning
- Optimization
- Diagnostics

This software can be operated as a standalone PC application, or integrated as a TIA-compatible program in SIMATIC STEP 7, or highly integrated into the SCOUT Engineering System (for SIMOTION). The basic functions and handling are the same in both cases.

In addition to the SINAMICS drives, STARTER also supports MICROMASTER 4 devices.

The project wizards can be used to create the drives within the structure of the project tree.

Beginners are supported by solution-based dialog guidance, whereby a standard graphics-based display maximizes clarity when setting the drive parameters.

First commissioning is guided by a wizard which makes all the basic settings in the drive. Therefore, getting a motor up and running is merely a question of setting a few of the drive parameters as part of the drive configuration process.

The individual settings required are made using graphics-based parameterization screens, which also precisely visualize the principle of operation of the drive.

Examples of individual settings that can be made include:

- How terminals are used
- Bus interface
- Setpoint channel (e.g., fixed setpoints)
- Closed-loop speed control (e.g., ramp-function generator, limits)
- BICO interconnections
- Diagnostics

For experts, the expert list can be used to specifically and quickly access individual parameters at any time. An individual compilation of frequently used parameters can be saved in dedicated user lists and watch tables.

In addition, the following functions are available for optimization purposes:

- Self-optimization of the controller settings (depending on drive unit)
- Setup and evaluation of trace recordings¹⁾
Tool function for recording 2 × 8 signals with
 - Measuring cursor function
 - Extensive trigger functions
 - Several Y scales
 - Sampling times in the current controller cycle clock

Diagnostics functions provide information about:

- Control/status words
- Parameter status
- Operating conditions
- Communication states

Performance features

- User-friendly: Only a small number of settings need to be made for successful first commissioning: The motor starts to rotate
- Solution-oriented dialog-based user guidance simplifies commissioning
- Self-optimization functions reduce manual effort for optimization.

Minimum system requirements

The following minimum requirements must be complied with:

- Hardware
 - PG or PC with Pentium III min. 1 GHz (recommended >1 GHz)
 - Work memory 1 GB (2 GB recommended)
 - Screen resolution 1024 × 768 pixels, 16-bit color depth
 - Free hard disk memory: min. 3 GB
- Software
 - Microsoft Internet Explorer V6.0 or higher
 - 32-bit operating systems:
 - Microsoft Windows XP Professional SP3
 - Microsoft Windows 7 Professional incl. SP1
 - Microsoft Windows 7 Ultimate incl. SP1
 - Microsoft Windows 7 Enterprise incl. SP1 (standard installation)
 - 64-bit operating systems:
 - Microsoft Windows 7 Professional SP1
 - Microsoft Windows 7 Ultimate SP1
 - Microsoft Windows 7 Enterprise SP1 (standard installation)
 - Microsoft Windows Server 2008 R2 SP1

Integration

Data can be exchanged (depending on the version) via PROFIBUS or PROFINET/Ethernet or via a serial interface.

For commissioning and service, a PG/PC can be connected to the CU320-2 Control Unit via PROFIBUS. A PROFIBUS connection must be available with a connecting cable at the PG/PC.

Further, communication between a CU320-2 Control Unit and PG/PC can also be established via Ethernet, either via an (optional) CBE20 Communication Board or the Ethernet interface -X127 on the CU320-2 Control Unit.

Note:

The terminal strip -X127 is suitable as a communication link to the PG/PC only for the purposes of servicing and commissioning.

¹⁾ Depending on drive unit.
Not supported for MICROMASTER 4,
SINAMICS G110, SINAMICS G120 <firmware V4.4,
SINAMICS G110D and SINAMICS G120D <firmware V4.5.

Selection and ordering data

Description	Article No.
STARTER commissioning tool for SINAMICS and MICROMASTER English, French, German, Italian, Spanish	6SL3072-0AA00-0AG0

Note:

In addition to the STARTER commissioning tool, SINAMICS Drive Control Chart (SINAMICS DCC) can be installed. This allows the device functionality in the SINAMICS drive system to be expanded with technology functions as required.

More information about SINAMICS DCC can be found in section "SINAMICS Drive Control Chart (SINAMICS DCC)".

Accessories

Depending on the version of the Control Unit (CU), the Control Unit of the drive unit can communicate with the programming device (PG) or PC via PROFIBUS or PROFINET/Ethernet or via a serial interface. The following accessories are available for the particular drive system as listed in the following table.

Description	Recommended accessories For communication between the drive unit and the programming device or PC Article No.	
SINAMICS S120		
• RS232	SIMATIC S7 connecting cable Null modem cable, 6 m	6ES7901-1BF00-0XA0
• PROFIBUS	CP 5711 communication module USB adapter for connecting a PG or notebook to PROFIBUS or MPI USB cable (2 m) included in scope of supply	6GK1571-1AA00
	SIMATIC DP plug-in cable 12 MBaud, for PG connection, pre-assembled with 2 × 9-pin SUB D connector, 3 m	6ES7901-4BD00-0XA0
• PROFINET/ Ethernet	Standard CAT5 Ethernet cable or PROFINET cable	—
SINAMICS S150		
• PROFIBUS	CP 5711 communication module USB adapter for connecting a PG or notebook to PROFIBUS or MPI USB cable (2 m) included in scope of supply	6GK1571-1AA00
	SIMATIC DP plug-in cable 12 MBaud, for PG connection, pre-assembled with 2 × 9-pin SUB D connector, 3 m	6ES7901-4BD00-0XA0
• PROFINET/ Ethernet	Standard CAT5 Ethernet cable or PROFINET cable	—

More information

The STARTER commissioning tool is also available on the Internet at www.siemens.com/starter

Tools and Engineering

SINAMICS Drive Control Chart (SINAMICS DCC)

Overview

SINAMICS Drive Control Chart (SINAMICS DCC) expands the scope of device functions by means of freely available closed-loop control, arithmetic and logic blocks and offers a means by which technological functions can be graphically configured in the SINAMICS drive system. SINAMICS DCC is the first stage of the Advanced Technology Function and is installed as an add-on to the STARTER commissioning tool.

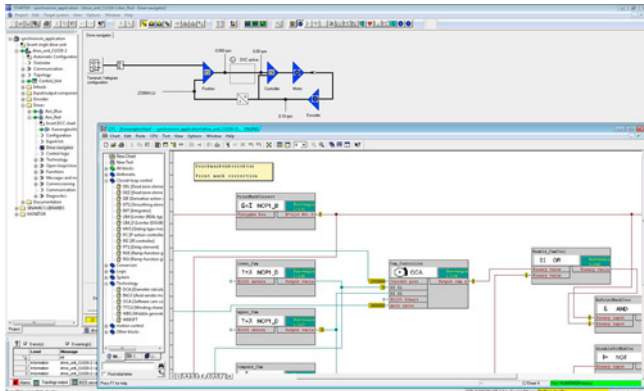

SINAMICS DCC provides users with greater scope to adapt these systems to the specific functions of their machines. SINAMICS DCC does not limit the number of functions that can be used. The number of functions is limited only by the performance capability of the Control Unit.

SINAMICS DCC is available for the following SINAMICS drive systems:

- SINAMICS G130
- SINAMICS G150
- SINAMICS S120
- SINAMICS S150
- SINAMICS DCM
- SINAMICS DCP
- SINAMICS GM150
- SINAMICS SM150
- SINAMICS GL150
- SINAMICS SL150

The user-friendly DCC editor enables easy graphics-based configuration, allows control loop structures to be clearly represented and provides a high degree of reusability of diagrams that have already been created.

The open-loop and closed-loop control functions are defined by using multi-instance-capable blocks (Drive Control Blocks (DCBs)) from a library (DCB library) that are selected and graphically linked with one another by dragging and dropping. Test and diagnostic functions allow the program behavior to be verified and, in the case of a fault, the cause identified.

Two types of DCB library are available, i.e. DCB Standard and DCB Extension. The DCB Standard library supplied with SINAMICS DCC contains a large selection of closed-loop, arithmetic and logic blocks, as well as comprehensive open-loop and closed-loop control functions.

For logically combining, evaluating and acquiring binary signals, all commonly used logic functions are available for selection (AND, XOR, on/off delay, RS flipflop, counter, etc.). A wide range of arithmetic functions, such as absolute value generation, dividers and minimum/maximum evaluation are available to monitor and evaluate numerical quantities. In addition to the closed-loop drive control, axial winder functions, PI controllers, ramp-function generators or wobble generators are simple to configure.

In addition to the standard library, the DCB Extension library is also available with SINAMICS DCC, firmware version V4.6 and higher. This contains an extended range of blocks that can be used as an additional, independent library in the DCC Editor.

DCB Extension provides new motion control blocks as a GMC library and blocks for supplementary mathematical and logical functions as a Math Extended library.

Using these blocks, it is possible to implement the following applications with SINAMICS DCC:

- Positioning
- 1:1 synchronous operation
- Gearing
- Gearing and positioning
- Camming
- Flying saws
- Cross cutters
- Calculation of trigonometric or logarithmic functions

These applications are available for downloading from the Siemens Application Support pages at:

www.siemens.com/sinamics-applications

With the blocks provided by DCB Extension, it is also possible to commission the programming of user-specific blocks.

SINAMICS DCC provides a convenient basis for resolving drive-level open-loop and closed-loop control tasks directly in the converter. This further extends the possibility of adapting SINAMICS to the particular application. Local data processing in the drive supports the implementation of modular machine concepts and results in an increase in the overall machine performance.

Minimum hardware and software requirements

See [STARTER commissioning tool](#).

Selection and ordering data

SINAMICS DCC comprises the graphical configuring tool (DCC Editor) and the DCB standard library. SINAMICS DCC is installed as an add-on to the STARTER commissioning tool.

The necessary engineering license for each PC (floating) for SINAMICS DCC is acquired at the same time the order is placed. No runtime license is required for the DCB standard library included in the scope of supply.

Existing licenses for SINAMICS DCC V2.1 and V2.2 SP1 and V2.3 are also valid for SINAMICS DCC V2.3 SP1.

An upgrade variant including an engineering license for applications with STARTER V4.4 SP1 is available for existing SINAMICS DCC V2.0 SPx.

Description	Article No.
SINAMICS DCC V2.3 SP1 for STARTER V4.4 SP1	
Graphic config. with SINAMICS DCC DCC Editor + DCB standard library	
• Single-user engineering license, with data carrier	6AU1810-1HA23-1XA0
• Upgrade engineering license, with data carrier	6AU1810-1HA23-1XE0

The blocks of the DCB Extension library are also configured with the graphical configuring tool (DCC Editor). Use of these blocks requires a runtime license.

Description	Article No.
SINAMICS DCB Extension license	6SL3077-0AA00-0AB0
Runtime license for license upgrading with firmware version V4.6 or later (can also be ordered in conjunction with the CompactFlash card, see CompactFlash card for CU310-2 and CU320-2 Control Units)	

Overview

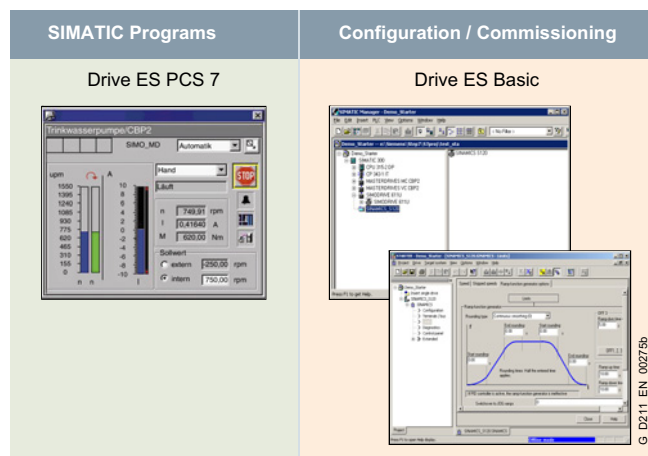

Drive ES is the engineering system used to integrate the communication, configuration and data management functions of Siemens drive technology into the SIMATIC automation world easily, efficiently and cost-effectively.

It is based on the STEP 7 Manager operator interface, the essential element when it comes to engineering.

Various software packages are available for selection:

- Drive ES Basic
- Drive ES PCS 7

Drive ES (**D**rive **E**ngineering **S**oftware) fully integrates drives from Siemens into the world of Totally Integrated Automation.

Design

Various software packages are available for selection:

- **Drive ES Basic**
- **Drive ES PCS 7** (APL Style or Classic Style)

Drive ES Basic

Drive ES Basic is for first-time users of the world of Totally Integrated Automation and the basic software for setting the parameters of all drives online and offline in this environment. Drive ES Basic enables both the automation system and the drives to be handled using the SIMATIC Manager software. Drive ES Basic is the starting point for common data archiving for complete projects and for extending the use of the SIMATIC teleservice to drives. Drive ES Basic provides the configuration tools for the new Motion Control functions – slave-to-slave communication, equidistance and isochronous operation with PROFIBUS DP and ensures that drives with PROFINET IO are simply integrated into the SIMATIC environment.

Note:

For SINAMICS and MICROMASTER 4 drives, this TIA functionality is also provided with the STARTER commissioning tool (V4.3.2 and above).

Drive ES PCS 7 (APL Style or Classic Style)

Drive ES PCS 7 links the drives with a PROFIBUS DP interface into the SIMATIC PCS 7 process control system, and it requires that SIMATIC PCS 7, V6.1 or higher has first been installed. Drive ES PCS 7 provides a function block library with function blocks for the drives and the corresponding faceplates for the operator station, which enables the drives to be operated from the PCS 7 process control system. From version V6.1 and higher, drives will also be able to be represented in the PCS 7 Maintenance Station.

In Drive ES PCS 7 version V8.0 and higher, two versions of the library are available: The APL (Advanced Process Library) variant and the previous version in the so-called Classic Style.

Contents of the Drive ES PCS 7 package (APL Style or Classic Style) in detail

- **Function block library for SIMATIC PCS 7** Faceplates and control blocks for SIMOVERT MASTERDRIVES VC and MC, as well as MICROMASTER/MIDIMASTER of the third and fourth generation as well as SIMOREG DC-MASTER and SINAMICS
- **STEP 7 slave object manager** for convenient configuration of drives and non-cyclic PROFIBUS DP communication with the drives
- **STEP 7 device object manager** for easy configuration of drives with PROFINET-IO interfaces (V8.0 SP1 and higher)
- **SETUP program** for installing the software in the PCS 7 environment

Tools and Engineering

Drive ES engineering software

Selection and ordering data

Description	Article No.
Drive ES Basic V5.5 SPx ^{*)} Configuration software for the integration of drives into TIA (Totally Integrated Automation) Requirement: STEP 7 from V5.3, SP3 and higher Type of delivery: DVD Languages: Ger, Eng, Fr, It, Sp with electronic documentation <ul style="list-style-type: none"> Floating license, 1 user Floating license, (copy license), 60 users Upgrade from V5.x to V5.5 SPx ^{*)} 	6SW1700-5JA00-5AA0 6SW1700-5JA00-5AA1 6SW1700-5JA00-5AA4
Drive ES PCS 7 V7.0 SPx ^{*)} Function block library for PCS 7 for the integration of drives Requirement: PCS 7 V7.0 and higher Type of delivery: CD-ROM Languages: Ger, Eng, Fr, It, Sp with electronic documentation <ul style="list-style-type: none"> Single-user license incl. 1 runtime license Runtime license (without data storage medium) Update service for single-user license 	6SW1700-7JD00-0AA0 6SW1700-5JD00-1AC0 6SW1700-0JD00-0AB2
Drive ES PCS 7 V7.1 SPx ^{*)} Function block library for PCS 7 for the integration of drives Requirement: PCS 7 V7.1 and higher Type of delivery: CD-ROM Languages: Ger, Eng, Fr, It, Sp with electronic documentation <ul style="list-style-type: none"> Single-user license incl. 1 runtime license Runtime license (without data storage medium) Update service for single-user license Upgrade from V6.x to V7.1 SPx ^{*)} 	6SW1700-7JD00-1AA0 6SW1700-5JD00-1AC0 6SW1700-0JD00-0AB2 6SW1700-7JD00-1AA4
Drive ES PCS 7 V8.0 SPx ^{*)} Function block library for PCS 7 for the integration of drives in Classic Style (as predecessor) Requirement: PCS 7 V8.0 and higher Type of delivery: CD-ROM Languages: Ger, Eng, Fr, It, Sp with electronic documentation <ul style="list-style-type: none"> Single-user license incl. 1 runtime license Runtime license (without data storage medium) Update service for single-user license Upgrade from V6.x to V8.0 SPx ^{*)} 	6SW1700-8JD00-0AA0 6SW1700-5JD00-1AC0 6SW1700-0JD00-0AB2 6SW1700-8JD00-0AA4
Drive ES PCS 7 APL V8.0 SPx ^{*)} Function block library for PCS 7 for the integration of drives in APL style (Advanced Process Library) Requirement: PCS 7 V8.0 and higher Type of delivery: CD-ROM Languages: Ger, Eng, Fr, It, Sp with electronic documentation <ul style="list-style-type: none"> Single-user license incl. 1 runtime license Runtime license (without data storage medium) Update service for single-user license Upgrade of APL V8.0 to V8.0 SP1 or Drive ES PCS7 V6.x, V7.x, V8.x classic to Drive ES PCS7 APL V8.0 SPx ^{*)} 	6SW1700-8JD01-0AA0 6SW1700-5JD00-1AC0 6SW1700-0JD01-0AB2 6SW1700-8JD01-0AA4

Description	Article No.
Drive ES PCS 7 V8.1 SPx ^{*)} Function block library for PCS 7 for the integration of drives in Classic Style (as predecessor) Requirement: PCS 7 V8.1 and higher Type of delivery: CD-ROM Languages: Ger, Eng, Fr, It, Sp with electronic documentation <ul style="list-style-type: none"> Single-user license incl. 1 runtime license Runtime license (without data storage medium) Update service for single-user license Upgrade from V6.x/V7.x/V8.x to V8.1 SPx ^{*)} 	6SW1700-8JD00-1AA0 6SW1700-5JD00-1AC0 6SW1700-0JD00-0AB2 6SW1700-8JD00-1AA4
Drive ES PCS 7 APL V8.1 SPx ^{*)} Function block library for PCS 7 for the integration of drives in APL style (Advanced Process Library) Requirement: PCS 7 V8.1 and higher Type of delivery: CD-ROM Languages: Ger, Eng, Fr, It, Sp with electronic documentation <ul style="list-style-type: none"> Single-user license incl. 1 runtime license Runtime license (without data storage medium) Update service for single-user license Upgrade of APL V8.x to V8.1 SPx ^{*)} or Drive ES PCS 7 V6.x, V7.x, V8.x classic to Drive ES PCS 7 APL V8.1 SPx ^{*)} 	6SW1700-8JD01-1AA0 6SW1700-5JD00-1AC0 6SW1700-0JD01-0AB2 6SW1700-8JD01-1AA4

Options

Drive ES software update service

A software update service can also be purchased for the Drive ES software. The user will automatically receive the latest software, service packs and full versions for one year after ordering.

The update service can only be ordered in addition to an existing (i.e. previously ordered) full version.

- Period of update service: 1 year

The update service is automatically extended by 1 further year unless canceled up to 6 weeks prior to expiration.

Description	Article No.
Drive ES PCS 7 <ul style="list-style-type: none"> Update service for single-user license 	6SW1700-0JD00-0AB2
Drive ES PCS 7 APL <ul style="list-style-type: none"> Update service for single-user license 	6SW1700-0JD01-0AB2

More information

Additional information is available on the Internet at www.siemens.com/drive-es

^{*)} Orders are automatically supplied with the latest Service Pack (SP).

Overview

Configuring with EPLAN



EPLAN is an engineering software for configuring electrical installations. The EPLAN platform combines expert systems for various disciplines, such as electrical, fluid and EMC engineering, as well as control cabinet and plant engineering. It provides the wiring information required to determine the optimal laying routes, connection lengths, bundle diameters, and design of the cable tree.

EPLAN Electric P8 – an EPLAN module – is CAE software specifically for configuring documentation and managing electrical automation projects for machines and systems. EPLAN Electric P8 offers the following functions:

- Creating circuit diagrams for control cabinets
- Managing article master data
- Automatic generation of bills of materials, terminal plans, PLC diagrams and overviews
- Preparation of the documentation for the configured system
- Design of the mechanical control cabinet configuration

EPLAN macros for SINAMICS components

EPLAN Electric P8 macros are available as downloads without charge, so that SINAMICS components can be easily and cost-effectively integrated into an EPLAN project. Macros are available for the following components:

- SINAMICS G120P, PM330 Power Modules
- SINAMICS G130 built-in units
- SINAMICS S120 chassis units
- SINAMICS DCM DC converters
- Line and motor-side components
- DC link components
- Control Units
- Supplementary system components

Using EPLAN Electric P8 macros substantially shortens the configuration time. All the necessary information about a component is supplied at the press of a button. This ensures that the data is up-to-date and correct – and mistakes/errors can be avoided.

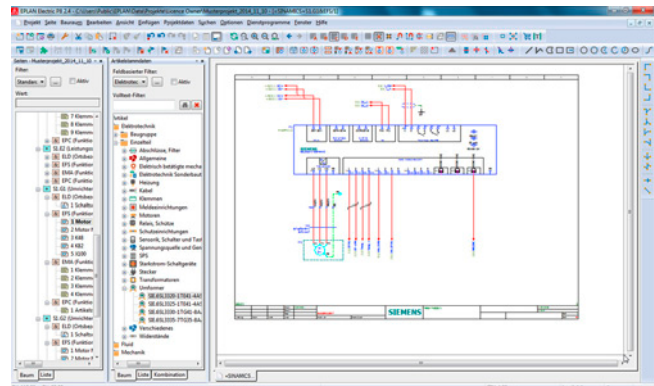

EPLAN user interface

The macros are provided in the file format EDZ (EPLAN Data Archived Zipped). An EDZ file is an archive for article master data, CAX data and macros. A macro in EDZ format contains the following data:

- Internal circuit diagrams
- Wiring diagrams
- Product master data
- Product images
- Data sheets

EPLAN Electric P8 macros for SINAMICS components are available in the following tools:

- Drive Technology Configurator (www.siemens.com/dt-configurator)
- CAX Onlinemanager
- Image database (download)

EPLAN projects for SINAMICS converter cabinet units

EPLAN projects are available for SINAMICS converter cabinet units, that simplify the configuration, and save time throughout the entire engineering process. EPLAN projects are available for the following converter cabinet units:

- SINAMICS G120P Cabinet
- SINAMICS G150
- SINAMICS G180
- SINAMICS S120 Cabinet Modules
- SINAMICS S150
- SINAMICS DCM Cabinet

The complete EPLAN project is supplied on a separate DVD-ROM together with the converter. The order is made by stating an additional Article No.

Tools and Engineering

Configuration with EPLAN

Overview (continued)

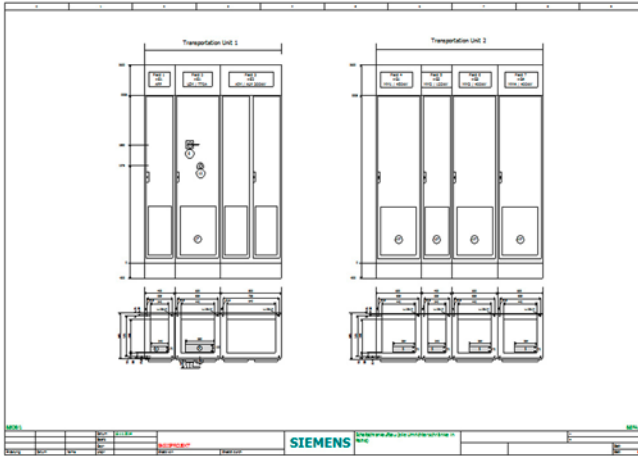

EPLAN project: Control cabinet layout

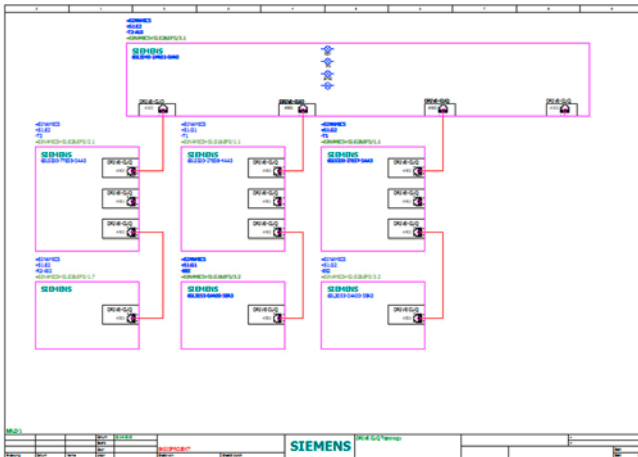

EPLAN project: DRIVE-CLiQ topology

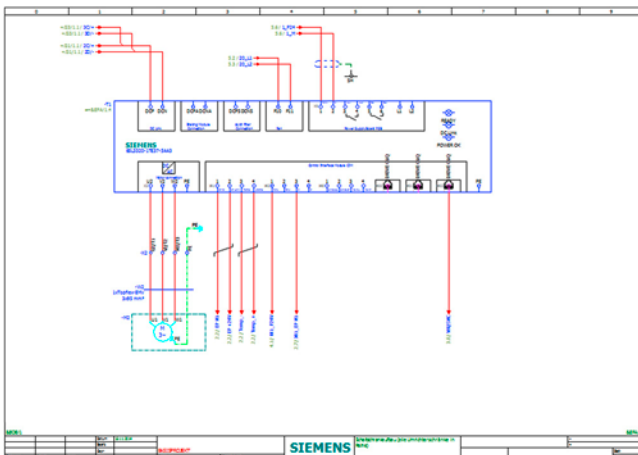

EPLAN project: Circuit diagram

The following data are available when you purchase the DVD-ROM:

- EPLAN project as a ZW1 file
- Updated, customer-specific, project article master database
- List of the article nos. created in the project
- A PDF version of the project

The EPLAN project includes the following documentation components:

- Title sheet
- Table of contents
- List of the structure identifiers used
- Single-line diagram
- General layout, external view
- General layout, internal view
- Circuit diagram
- Terminal diagram
- Connector diagram
- Parts list
- Order list/complete parts list

Selection and ordering data

Description	Article No.
EPLAN Electric P8 Project documentation on DVD-ROM for: <ul style="list-style-type: none"> • SINAMICS G120 P Cabinet • SINAMICS S120 Cabinet Modules • SINAMICS S150 • SINAMICS G150 	6SL3780-0AK00-0AA0

Overview

General procedure when engineering

The function description of the machine provides the basis for the configuration. The definition of the components is based on physical interdependencies and is usually carried out as follows:

Step "Description of configuration activity"

Step	Description of configuration activity
1	Clarification of type of drive
2	Specification of the supplementary conditions and integration in the automation system
3	Definition of the load, calculation of the max. load torque, selection of the motor
4	Definition of the Motor Module
5	Repetition of steps 3 and 4 for additional axes
6	Calculation of the required DC link power and definition of the Line Module
7	Specification of the required control performance and selection of the Control Unit, definition of component cabling
8	Specification of the line-side power options (main switch, fuses, line filters, etc.) and cable cross-sections for system connection and motor connection
9	Definition of additional system components
10	Calculation of the current requirement for the 24 V DC supply for the components and specification of power supplies (SITOP devices, Control Supply Modules)
11	Specification of components for connection system
12	Configuration of drive line-up components
13	Thermal design of the control cabinet

Configuration begins with the mechanical interface to the machine. A suitable motor is selected according to the specified torques and speeds. A matching power unit is then also chosen. Depending on the requirements of the machine, the motor is supplied as a single drive via a Power Module or within a multi-motor drive group via a Motor Module. Once the basic components have been defined, the system components for matching to the electrical and mechanical interfaces are selected.

The SIZER configuring tool helps the user to select the correct components quickly and easily. After entering the relevant torque and speed characteristics, the user, assisted by SIZER, can progress confidently through the configuring process, identifying suitable motors and matching SINAMICS power units and other system components.

Important information about SINAMICS S120 components that are needed to create a drive system subject to certain supplementary conditions can be found in the SINAMICS Low Voltage Engineering Manual, and in the online help for the SIZER configuring tool.

EMC notes

The electromagnetic compatibility describes - according to the definition of the EMC Directive - the "capability of a device to work satisfactorily in the electromagnetic environment without itself causing electromagnetic interference which is unacceptable for other devices present in this environment". To guarantee that the appropriate EMC Directives are observed, the devices must demonstrate a sufficiently high noise immunity, and also the emitted interference must be limited to acceptable values.

The product standard EN 61800-3 describes the EMC requirements placed on "Variable-speed drive systems". A variable-speed drive system (or Power Drive System PDS) consists of the drive converter and the electric motor including cables. The driven machine is not part of the drive system.

EN 61800-3 defines different limit values depending on the site of installation of the drive system, referred to as the first and second environments.

Residential buildings or locations at which the drive system is directly connected to a public low-voltage supply without intermediate transformer are defined as the **first environment**.

A **second environment** refers to all locations outside residential areas, or industrial sites which are supplied from the medium-voltage network via a separate transformer.

Four different categories are defined in EN 61800-3 Ed.2 depending on the installation site and the output power of the drive:

- **Category C1:** Drive systems for rated voltages less than 1000 V for unrestricted use in the first environment.
- **Category C2:** Stationary drive systems for rated voltages less than 1000 V for use in the second environment. Use in the first environment is possible if the drive system is marketed and installed by qualified personnel. The warning information and installation instructions supplied by the manufacturer must be observed.
- **Category C3:** Drive systems for rated voltages less than 1000 V for exclusive use in the second environment.
- **Category C4:** Drive systems for rated voltages greater than or equal to 1000 V or for rated currents greater than or equal to 400 A for use in complex systems in the second environment.

The following diagram shows how the four categories are assigned to the first and second environments:

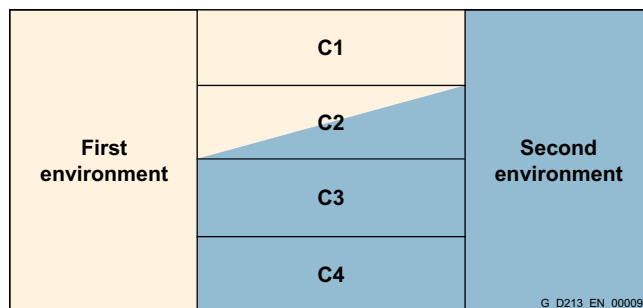

SINAMICS S150 is almost exclusively used in the second environment (Categories C3 and C4).

To limit the **emitted interference**, SINAMICS S150 is equipped with a line filter as standard, according to the limits defined in Category C3. Optional line filters are available on request for use in the first environment (Category C2).

SINAMICS S150 fulfills the requirements pertaining to **noise immunity** defined in EN 61800-3 for the second environment and thus also the lower noise immunity values in the first environment.

The warning and installation information (part of the equipment documentation) must be observed.

Overview



To correctly select and configure the devices listed in this catalog, we would like to refer to the SINAMICS Low Voltage Engineering Manual. This supplements the Catalogs D 11 and D 21.3, and is intended to simplify the handling of SINAMICS series devices.

This manual is only available in electronic form and only in German and English. It is available as a PDF in the Information and Download Center:

<https://support.industry.siemens.com/cs/document/83180185>

The Engineering Manual contains general information on the basics of variable-speed electric AC drives, as well as detailed system descriptions and direct specifications for the following SINAMICS series devices:

- SINAMICS G130 Drive Converter Chassis Units (Catalog D 11)
- SINAMICS G150 Drive Converter Cabinet Units (Catalog D 11)
- SINAMICS S120 Modular Chassis Units (Catalogs D 21.3 and PM 21 / "SINAMICS S120 Drive System")
- SINAMICS S120 Cabinet Modules (Catalog D 21.3)
- SINAMICS S150 Converter Cabinet Units (Catalog D 21.3)

The Engineering Manual is divided into several sections with different layouts.

The first chapter – Basics and system description – essentially explains the physical basics of variable-speed electric AC drives and provides a generally valid system description of the SINAMICS series devices.

The second chapter – EMC design guideline – discusses the topic of **E**lectromagnetic **C**ompatibility (EMC) and provides all the information required to configure and install drives with the specified SINAMICS devices in compliance with EMC guidelines.

The following chapters – Configuration of the SINAMICS G130, G150, S120 chassis units, S120 Cabinet Modules and S150 devices – discuss device-specific topics, which go beyond the contents of the generally valid system descriptions.

The information provided addresses technically qualified and trained personnel. It is the responsibility of the configuration engineer to evaluate the completeness of the information provided for the respective application. This person also has the final system responsibility for the entire drive or the plant.

Services and Documentation



7/2	Partner at Siemens
7/3	Online Services
7/3	Information and Ordering Options on the Internet and DVD
7/4	Information and Download Center, Social Media, Mobile Media
7/5	Industry Services
7/6	Portfolio
7/8	Online Support
7/9	Service & Support
7/9	Extension of the liability for defects
7/11	Training
7/12	SIMATIC training courses
7/13	SPARES on Web
7/14	My Documentation Manager
7/15	Documentation

Services and Documentation

Partner at Siemens

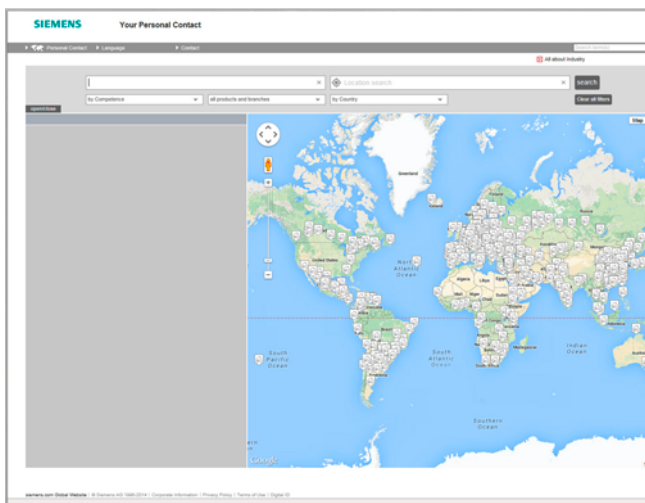

At Siemens we are resolutely pursuing the same goal: long-term improvement of your competitive ability. We are committed to this goal. Thanks to our commitment, we continue to set new standards in automation and drive technology. In all industries – worldwide.

At your service locally, around the globe for consulting, sales, training, service, support, spare parts ... on the entire Industry Automation and Drive Technologies range.

Your personal contact can be found in our Contacts Database at: www.siemens.com/automation/partner

You start by selecting

- the required competence,
- products and branches,
- a country,
- a city

or by a

- location search or
- person search.

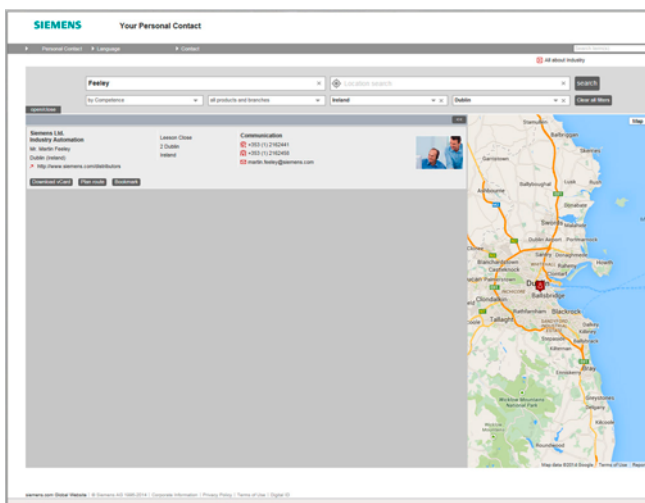
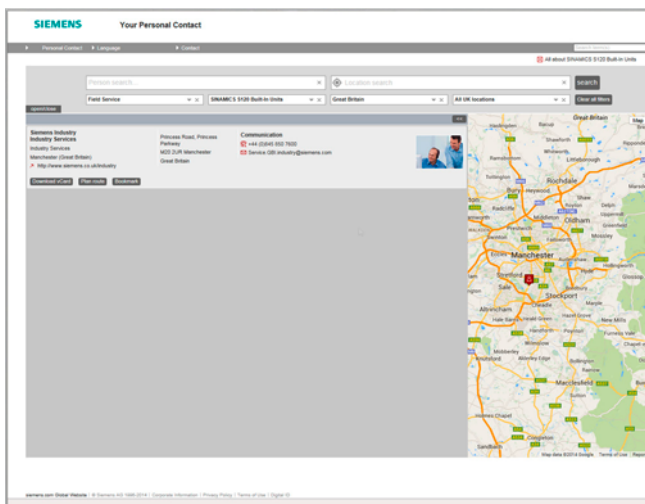

7

The Future of Manufacturing on the Internet



Detailed knowledge of the range of products and services available is essential when planning and engineering automation systems. It goes without saying that this information must always be as up-to-date as possible.

Industry is on the threshold of the fourth industrial revolution as digitization now follows after the automation of production. The goals are to increase productivity and efficiency, speed, and quality. In this way, companies can remain competitive on the path to the future of industry.

You will find everything you need to know about products, systems and services on the internet at:

www.siemens.com/industry

Product Selection Using the Interactive CA 01 Automation and Drives Catalog

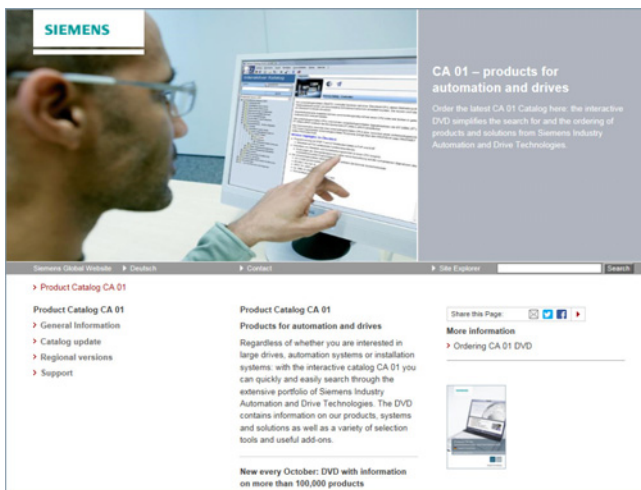

Detailed information together with user-friendly interactive functions:

The CA 01 interactive catalog covers more than 100,000 products, thus providing a comprehensive overview of the product range provided by Siemens.

You will find everything you need here for solving tasks in the fields of automation, switching, installation and drives. All information is provided over a user interface that is both user-friendly and intuitive.

You can order the CA 01 product catalog from your Siemens sales contact or in the Information and Download Center:

www.siemens.com/industry/infocenter

Information about the CA 01 interactive catalog can be found on the Internet at:

www.siemens.com/automation/ca01

or on DVD.

Easy Shopping with the Industry Mall

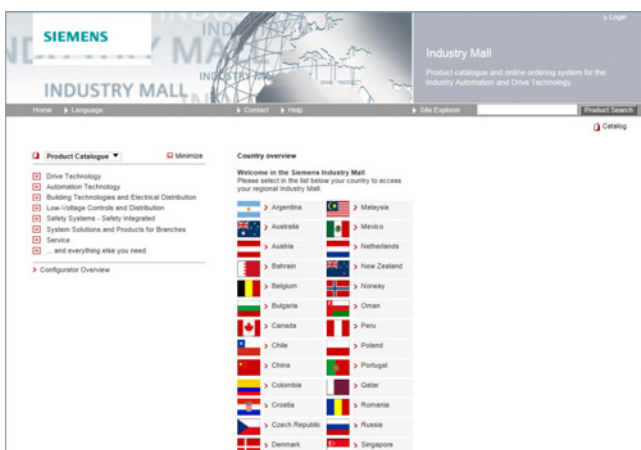

The Industry Mall is the electronic ordering platform of Siemens AG on the Internet. Here you have online access to a huge range of products presented in an informative and attractive way.

Data transfer via EDIFACT allows the whole procedure, from selection through ordering to tracking and tracing, to be carried out online. Availability checks, customer-specific discounts and bid creation are also possible.

Numerous additional functions are provided for your support. For example, powerful search functions make it easy to select the required products. Configurators enable you to configure complex product and system components quickly and easily. CAx data types are also provided here.

You can find the Industry Mall on the Internet at:

www.siemens.com/industrymall

Services and Documentation

Online Services

Information and Download Center, Social Media, Mobile Media

Downloading Catalogs

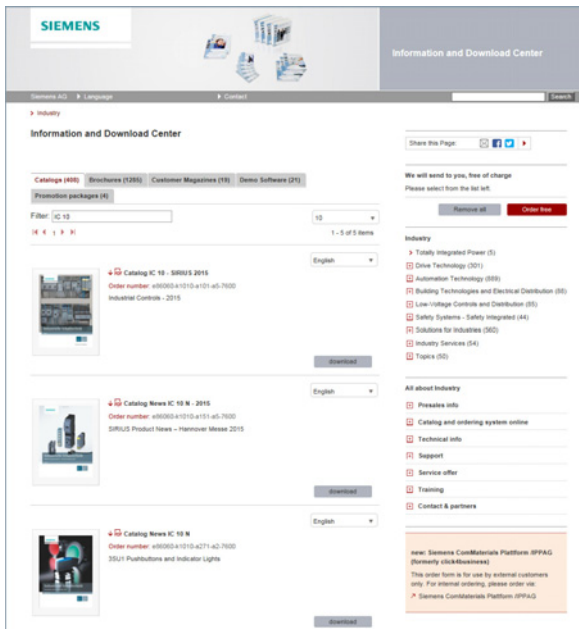

In addition to numerous other useful documents, you can also find the catalogs listed on the back inside cover of this catalog in the Information and Download Center. You can download these catalogs in PDF format without having to register.

The filter dialog above the first catalog displayed makes it possible to carry out targeted searches. If you enter "MD 3" for example, you will find both the MD 30.1 and MD 31.1 catalogs. If you enter "IC 10", both the IC 10 catalog and the associated news or add-ons are displayed.

Visit us at:

www.siemens.com/industry/infocenter

Social and Mobile Media

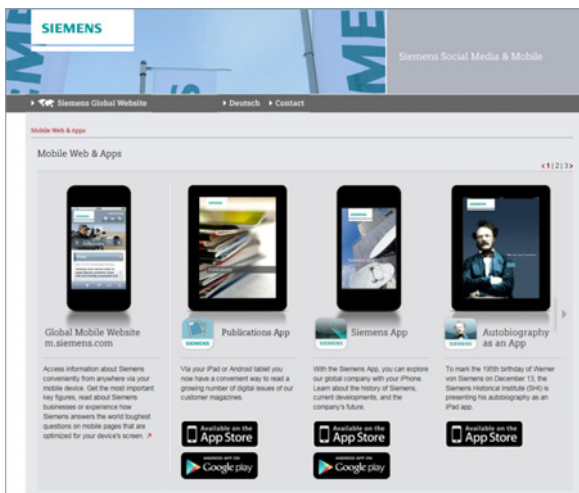

Connect with Siemens through social media: visit our social networking sites for a wealth of useful information, demos on products and services, the opportunity to provide feedback, to exchange information and ideas with customers and other Siemens employees, and much, much more. Stay in the know and follow us on the ever-expanding global network of social media.

To find out more about Siemens' current social media activities, visit us at:

www.siemens.com/socialmedia

Or via our product pages at:

www.siemens.com/automation or www.siemens.com/drives

Connect with Siemens Industry at our central access point to read all the news on the future of manufacturing, watch current videos and inform yourself about all the latest industry developments:

www.siemens.com/future-of-manufacturing/news.html

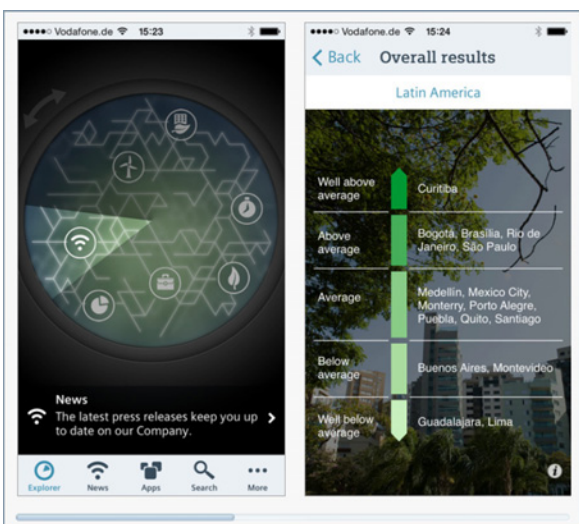

Discover the world of Siemens.

We are also constantly expanding our offering of cross-platform apps for smartphones and tablets. You will find the current Siemens apps at the App Store (iOS) or at Google Play (Android):

<https://itunes.apple.com/en/app/siemens/id452698392?mt=8>

<https://play.google.com/store/search?q=siemens>

The Siemens app, for example, tells you all about the history, latest developments and future plans of the company – with informative pictures, fascinating reports and the most recent press releases.

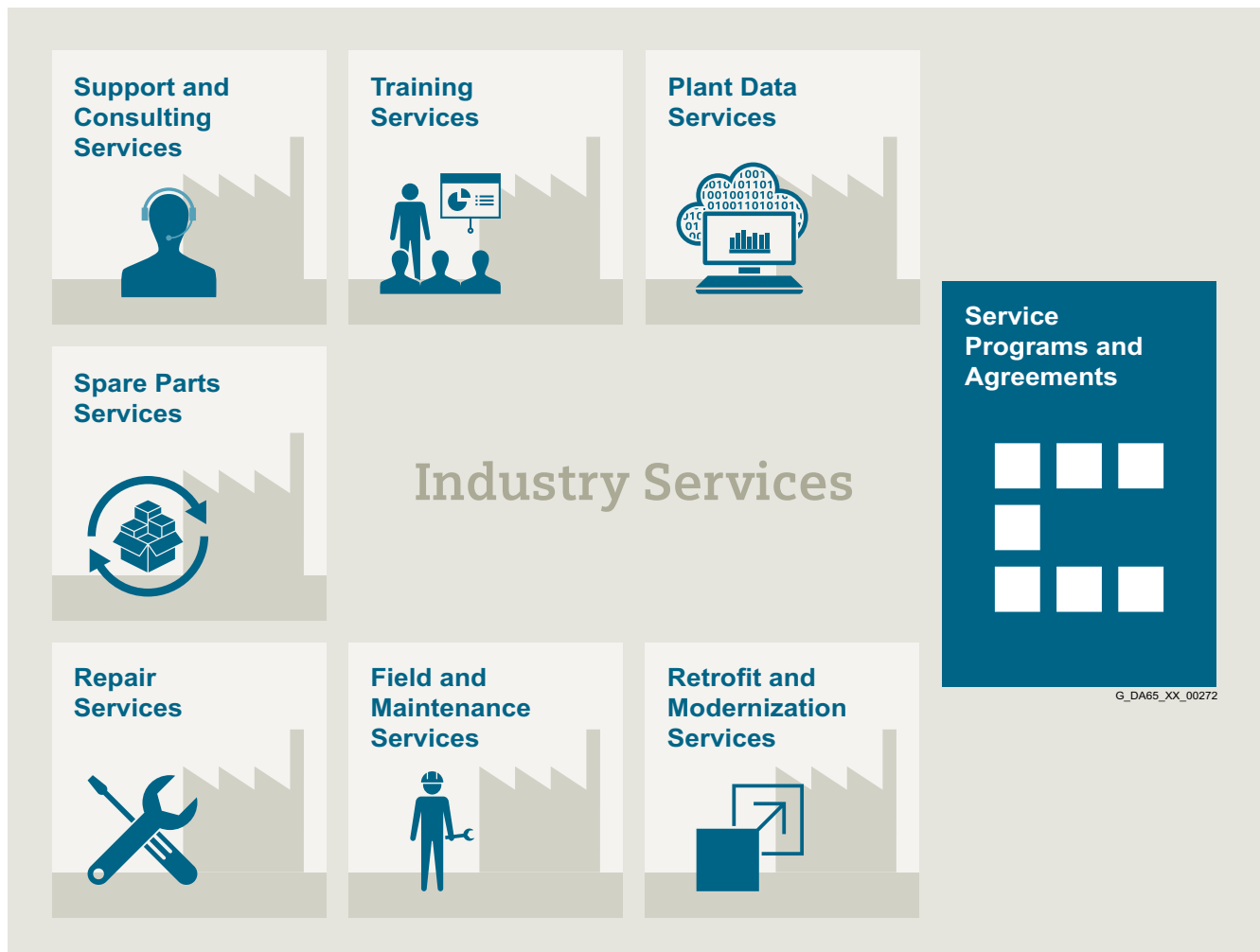
Overview
Unleash potential – with services from Siemens

Increase your performance – with Industry Services

Optimizing the productivity of your equipment and operations can be a challenge, especially with constantly changing market conditions. Working with our service experts makes it easier. We understand your industry's unique processes and provide the services needed so that you can better achieve your business goals.

You can count on us to maximize your uptime and minimize your downtime, increasing your operations' productivity and reliability. When your operations have to be changed quickly to meet a new demand or business opportunity, our services give you the flexibility to adapt. Of course, we take care that your production is protected against cyber threats. We assist in keeping your operations as energy and resource efficient as possible and reducing your total cost of ownership. As a trendsetter, we ensure that you can capitalize on the opportunities of digitalization and by applying data analytics to enhance decision making: You can be sure that your plant reaches its full potential and retains this over the longer lifespan.

You can rely on our highly dedicated team of engineers, technicians and specialists to deliver the services you need – safely, professionally and in compliance with all regulations. We are there for you, where you need us, when you need us.

Services and Documentation

Industry Services

Industry Services – Portfolio overview

Overview

Plant Data Services



Make your industrial processes transparent to gain improvements in productivity, asset availability, and energy efficiency.

Production data is generated, filtered and translated with intelligent analytics to enhance decision-making.

This is done whilst taking data security into consideration and with continuous protection against cyber attack threats.

www.industry.siemens.com/services/global/en/portfolio/plant-data-services/Pages/index.aspx

Support and Consulting Services



Industry Online Support site for comprehensive information, application examples, FAQs and support requests.

Technical and Engineering Support for advice and answers for all inquiries about functionality, handling, and fault clearance.

Information & Consulting Services, e.g. SIMATIC System Audit; clarity about the state and service capability of your automation system or Lifecycle Information Services; transparency on the lifecycle of the products in your plants.

www.industry.siemens.com/services/global/en/portfolio/support-consulting/Pages/index.aspx

Training Services



From the basics and advanced to specialist skills, SITRAIN courses provide expertise right from the manufacturer – and encompass the entire spectrum of Siemens products and systems for the industry.

Worldwide, SITRAIN courses are available wherever you need a training course in more than 170 locations in over 60 countries.

www.industry.siemens.com/services/global/en/portfolio/training/Pages/index.aspx

Spare Parts Services



Are available worldwide for smooth and fast supply of spare parts – and thus optimal plant availability. Genuine spare parts are available for up to ten years. Logistic experts take care of procurement, transport, custom clearance, storage and order management. Reliable logistics processes ensure that components reach their destination as needed.

Asset optimization services help you design a strategy for parts supply where your investment and carrying costs are reduced and the risk of obsolescence is avoided.

www.industry.siemens.com/services/global/en/portfolio/spare_parts/Pages/index.aspx

Overview (continued)

Repair Services



Are offered on-site and in regional repair centers for fast restoration of faulty devices' functionality.

Also available are extended repair services, which include additional diagnostic and repair measures, as well as emergency services.

www.industry.siemens.com/services/global/en/portfolio/repair_services/Pages/index.aspx

Retrofit and Modernization Services



Provide a cost-effective solution for the expansion of entire plants, optimization of systems or upgrading existing products to the latest technology and software, e.g. migration services for automation systems.

Service experts support projects from planning through commissioning and, if desired over the entire extended lifespan, e.g. Retrofit for Integrated Drive Systems for an extended lifetime of your machines and plants

www.industry.siemens.com/services/global/en/portfolio/retrofit-modernization/Pages/index.aspx

Field and Maintenance Services



Siemens specialists are available globally to provide expert field and maintenance services, including commissioning, functional testing, preventive maintenance and fault clearance. All services can be included in customized service agreements with defined reaction times or fixed maintenance intervals.

www.industry.siemens.com/services/global/en/portfolio/field_service/Pages/index.aspx

Service Programs and Agreements



A technical Service Program or Agreement enables you to easily bundle a wide range of services into a single annual or multi-year agreement.

You pick the services you need to match your unique requirements or fill gaps in your organization's maintenance capabilities.

Programs and agreements can be customized as KPI-based and/or performance-based contracts.

www.industry.siemens.com/services/global/en/portfolio/service_programs/Pages/index.aspx

Services and Documentation

Industry Services

Online Support

Overview



Online Support is a comprehensive information system for all questions relating to products, systems, and solutions that Siemens has developed for industry over time. With more than 300,000 documents, examples and tools, it offers users of automation and drive technology a way to quickly find up-to-date information. The 24-hour service enables direct, central access to detailed product information as well as numerous solution examples for programming, configuration and application.

Online Support App

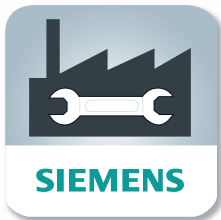

Using the Online Support app, you can access over 300,000 documents covering all Siemens industrial products – anywhere, any time. Regardless of whether you need help implementing your project, fault-finding, expanding your system or are planning a new machine.

You have access to FAQs, manuals, certificates, characteristic curves, application examples, product notices (e.g. announcements of new products) and information on successor products in the event that a product is discontinued.

Just scan the product code printed on the product directly using the camera of your mobile device to immediately see all technical information available on this product at a glance. The graphical CAx information (3D model, circuit diagrams or EPLAN macros) is also displayed. You can forward this information to your workplace using the e-mail function.

The search function retrieves product information and articles and supports you with a personalized suggestion list. You can find your favorite pages – articles you need frequently – under “mySupport”. You also receive selected news on new functions, important articles or events in the News section.

The content, in six languages, is increasingly multimedia-based – and now also available as a mobile app. Online support’s “Technical Forum” offers users the opportunity to share information with each other. The “Support Request” option can be used to contact Siemens’ technical support experts. The latest content, software updates, and news via newsletters and Twitter ensure that industry users are always up to date.

www.siemens.com/industry/onlinesupport

Scan the QR code
for information on
our Online Support
app.



The app is available free of charge from the Apple App Store (iOS) or from Google Play (Android).

<https://support.industry.siemens.com/cs/ww/en/sc/2067>

Extension of the liability for defects

We provide the option of extending the liability for defects period beyond the normal period for our SINAMICS S120 Cabinet Modules and SINAMICS S150 cabinet units. The standard liability for defects period, as listed in our standard conditions for the supply of services and products, is 12 months.

1. Extended liability for defects when ordering new products

When ordering new products, it is possible to extend the standard liability for defects period for an additional price. Various extension periods can be selected.

Extended liability for defects for converters	
Additional ordering data -Z with order code	Additional text
Q80	Extension of the liability for defects period by 12 months to a total of 24 months (2 years) after being delivered
Q81	Extension of the liability for defects period by 18 months to a total of 30 months (2½ years) after being delivered
Q82	Extension of the liability for defects period by 24 months to a total of 36 months (3 years) after being delivered
Q83	Extension of the liability for defects period by 30 months to a total of 42 months (3½ years) after being delivered
Q84	Extension of the liability for defects period by 36 months to a total of 48 months (4 years) after being delivered
Q85	Extension of the liability for defects period by 48 months to a total of 60 months (5 years) after being delivered

2. Extended liability for defects period after the product has already been delivered

If a product has already been delivered, an extended liability for defects period can be ordered if the original liability for defects period has still not expired. In addition to the article number specified on the rating plate, the serial number must also be stated in the order.

The following article numbers are used:

Extended liability for defects for converters	
Article No.	Text
9LD1730-0AA24	Extension of the liability for defects period by 12 months to a total of 24 months (2 years) after being delivered
9LD1730-0AA30	Extension of the liability for defects period by 18 months to a total of 30 months (2½ years) after being delivered
9LD1730-0AA36	Extension of the liability for defects period by 24 months to a total of 36 months (3 years) after being delivered
9LD1730-0AA42	Extension of the liability for defects period by 30 months to a total of 42 months (3½ years) after being delivered
9LD1730-0AA48	Extension of the liability for defects period by 36 months to a total of 48 months (4 years) after being delivered
9LD1730-0AA60	Extension of the liability for defects period by 48 months to a total of 60 months (5 years) after being delivered

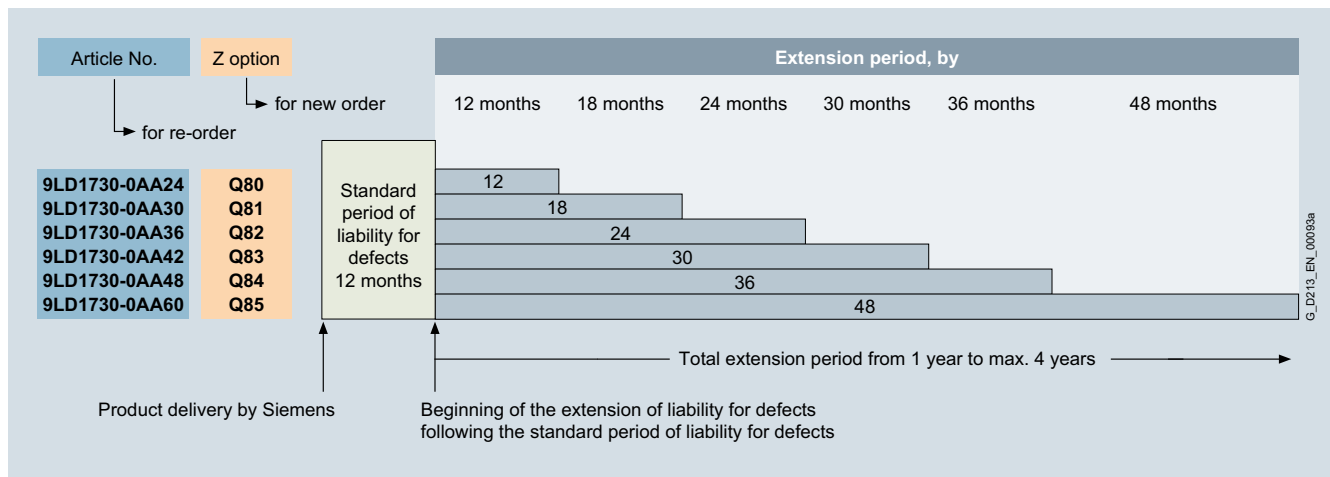
Overview of the extended liability for defects period

Services and Documentation

Service & Support

Extension of the liability for defects

Conditions for an extension of the liability for defects:

1. The liability for defects period can be extended only once, i.e. it is not possible to extend an extension. If a product has already been delivered, an extended liability for defects period can only be ordered if the original liability for defects period has still not expired.
2. The scope of services provided by an extended liability of defects period includes all material and work expenditure by Siemens for rectification of the damage and, where applicable, all travel costs and expenses.
3. For all extension periods of liability for defects, when ordering a new product and when reordering, the final destination of the product must be known (region in which the equipment will be finally installed). The EUNA process can be used to obtain this information, which is available at www.siemens.com/euna
4. The general storage conditions described in the operating instructions must be adhered to, especially the specifications for long-term storage. These specifications must be requested separately from Siemens if necessary.
5. Commissioning must be performed by appropriately qualified personnel. When making liability for defect claims, under certain circumstances, it may be necessary to submit the commissioning report to the department making the decision.
6. For all liability of defect extensions, all of the regular maintenance intervals must be complied with according to what is specified in the operating instructions. When ordering the appropriate maintenance, this must be carried out by Siemens or by personnel authorized by Siemens. The corresponding maintenance documentation and history must be submitted when making liability for defect claims.
7. The operating conditions correspond to the specifications and data provided in the operating instructions, in the engineering manual or special conditions specified in the specific contract.
8. The extended liability for defects excludes wearing parts such as fans or filters. This does not apply if it can be clearly proven that the failure is a premature one.
9. Otherwise, the general conditions regarding liability for defects applies as agreed in the delivery contract.

Overview

Faster and more applicable know-how: Hands-on training from the manufacturer

Siemens Industry Training provides you with comprehensive support in solving your tasks.

Training by the market leader in the industry enables you to make independent decisions with confidence. Especially where the optimum and efficient use of products and plants are concerned. You can eliminate deficiencies in existing plants, and exclude expensive faulty planning right from the beginning.



First-class know-how directly pays for itself: In shorter commissioning times, high-quality end products, faster troubleshooting and reduced downtimes. In other words, increased profits and lower costs.

Achieve more with Siemens Industry Training

- Shorter times for commissioning, maintenance and servicing
- Optimized production operations
- Reliable configuration and commissioning
- Minimization of plant downtimes
- Flexible plant adaptation to market requirements
- Compliance with quality standards in production
- Increased employee satisfaction and motivation
- Shorter familiarization times following changes in technology and staff

Siemens Industry Training is characterized by

Top trainers

Our trainers are skilled teachers with direct practical experience. Course developers have close contact with product development, and directly pass on their knowledge to the trainers.

Practical relevance

The practical experience of our trainers enables them to teach theory effectively. We also place the highest emphasis on practical exercises, which make up to half of the course time. You can therefore immediately implement your new knowledge in practice. We train you methodically on state-of-the-art training equipment. This training approach will give you all the confidence you need.

Wide variety

With a total of about 300 local attendance courses, we train the complete range of products from Siemens Industry as well as interaction of the products in systems.

Customized training

We are only a short distance away. You can find us at more than 50 locations in Germany, and in 62 countries worldwide. You wish to have individual training instead of one of our 300 courses? Our solution: We will provide a program tailored exactly to your personal requirements. Training can be carried out in our Training Centers or at your company location.

The right mixture: Blended learning

"Blended learning" is a combination of various training media and sequences. For example, a participant based course in a Training Center can be optimally supplemented by a self-teach program as preparation or follow-up. Additional effect: Reduced traveling costs and periods of absence.



More information

Contact

Visit us on the Internet at www.siemens.com/sitrain

or let us advise you personally. You can request our latest training catalog from:

Siemens Industry Training Customer Support Germany:

Tel.: +49 (911) 895-7575

Fax: +49 (911) 895-7576

E-mail: info@sitrain.com

Services and Documentation

Training

SIMATIC training courses

Overview

Range of training courses for the SINAMICS S120 and SINAMICS S150 drive systems

Here you will find an overview of the training courses available for SINAMICS S120 and SINAMICS S150.

The courses are modular in design and are directed at a variety of target groups as well as individual customer requirements.

The system overview will acquaint decision-makers and sales personnel with the system very quickly.

The basic and follow-up courses are guaranteed to provide all of the technical knowledge that service personnel will need for commissioning and service.

All courses contain as many practical exercises as possible in order to enable intensive and direct training on the drive system and with the tools in small groups.

You will find further information about course contents and dates in Catalog ITC and on the Internet.

Title (all courses are available in English and/or German)	Target group			Duration	Course code
	Sales personnel, planners, decision makers	Commissioning engineers, programmers	Service personnel, maintenance technicians		
SINAMICS System Overview	✓	–	–	2 days	DR-SN-UEB
Integrated Drive Systems Introduction and Fundamentals	✓	–	–	3 days	DR-IDS
SIMOTICS induction motors Planning and Configuration	✓	–	–	3 days	DR-ASM-PL
SINAMICS S120 Configuration	✓	✓	–	5 days	DR-SNS-PRJ
SINAMICS S120 Safety Integrated	✓	✓	–	4 days	DR-SNS-SAF
SINAMICS S120 Control Optimization	–	✓	–	3 days	DR-S12-OPT
SINAMICS S120 Service and Commissioning	–	✓	✓	5 days	DR-SNS-SI
SINAMICS S120 Parameterization Advanced Course	–	✓	✓	5 days	DR-S12-PA
SINAMICS S120 Advanced Course Service on Chassis Units	–	✓	✓	2 days	DR-SNS-CHA
SINAMICS G150/G130/S150 Commissioning and Service	–	✓	✓	5 days	DR-SNG-SI
SINAMICS G150/G130/S150 Diagnostics and Service	–	✓	✓	5 days	DR-G15-DG
SINAMICS S120 Maintenance	–	–	✓	5 days	DR-SNS-IH
SINAMICS on PROFINET and PROFIBUS - Diagnostics and Service	–	–	✓	3 days	DR-NET-DG

Overview

Spares on Web – Identification of spare parts on the Internet

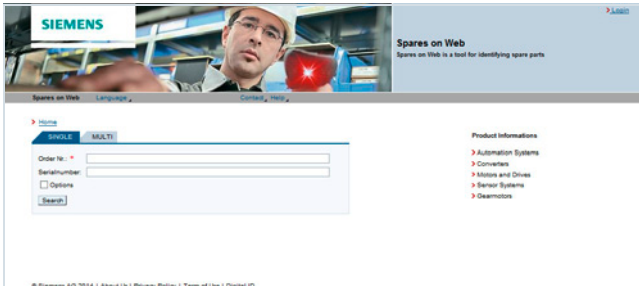

Spares on Web is a web-based tool for identifying spare parts. After you have entered the Article No. and serial number, the spare parts available for the relevant unit are displayed.

www.siemens.com/sow

Services and Documentation

My Documentation Manager

Overview

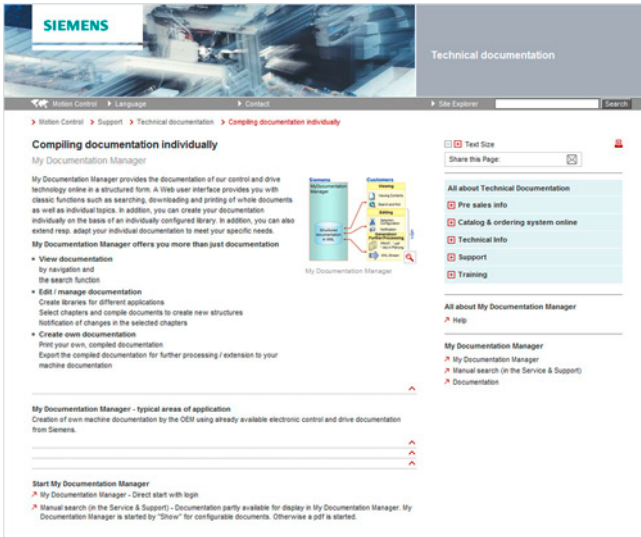

My Documentation Manager – Customizing information

My Documentation Manager offers all Motion Control customers an innovation with extended usability: Machine manufacturers and end customers are not only able to assemble their own customized technical documents for a specific product or system, they can also generate complete libraries with individually configured contents. The content that matches your topic can be found from the full range of documentation stored under Service & Support using the operator interface and assembled using drag & drop into application-based libraries, generated and even combined with your own documentation. The self-generated collections can be saved in the commonly used RTF and PDF formats or even in XML format.

You must register for configuring and generating/managing (the existing login can be used, e.g. Industry Mail www.siemens.com/industrymail)

Benefits

- Display
View, print or download standard documents or personalized documents
- Configure
Transfer standard documents or parts of them to personalized documents
- Generate/Manage
Produce and manage personalized documents in the formats PDF, RTF or XML

Design

My Documentation Manager is the web-based system to generate personalized documentation based on standard documents. It is part of the Service & Support Portal.

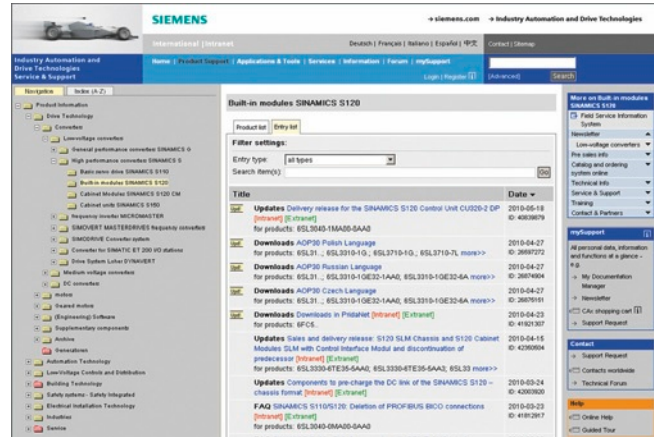

Search in the Service & Support portal

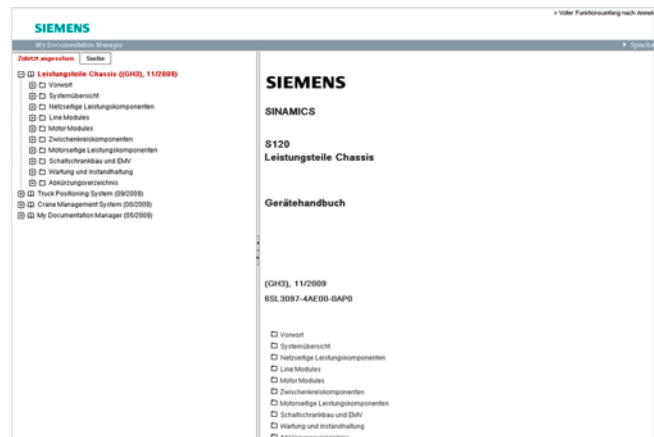

Document in My Documentation Manager

Function

Opening My Documentation Manager

My Documentation Manager opens in two ways

- Search in the Service & Support portal <https://support.industry.siemens.com>
The appropriate manuals are designated by "configurable". My Documentation Manager opens by clicking on "Display and configure". The selected document is displayed as the current document.
- Using the direct link from the Service & Support portal www.automation.siemens.com/docconf/
After logon/registration, the online help is displayed as current document.

More information

You can find more information on the Internet at www.siemens.com/mdm

Overview**SINAMICS S120 Cabinet Modules and
SINAMICS S150 Converter Cabinet Units**

The documentation is provided as standard in PDF format on CD-ROM, and comprises the following sections:

- Description
- Installation instructions
- Commissioning guide
- Function description
- Maintenance information
- Engineering manual
- Lists of spare parts

As well as device-specific documentation, such as circuit diagrams, dimension drawings, layout diagrams and terminal diagrams.

Documentation in English/German is supplied as standard with the device.

The scope of delivery also includes a DVD-ROM with the STARTER commissioning tool.

If one of the languages subsequently listed is required, when ordering this should be specified using the corresponding option order code (see [Description of options](#)):

Language	Order code
English/French	D58
English/Spanish	D60
English/Italian	D80
English/Chinese	D91
English/Russian	D94

Configuring documents/documentation available for downloading at:

For SINAMICS S120 Cabinet Modules
<https://support.industry.siemens.com/cs/ww/en/ps/13233/man>

For SINAMICS S150
<https://support.industry.siemens.com/cs/ww/en/ps/13234/man>

SINAMICS S120 Chassis Format Units

Comprehensive documentation is available for the SINAMICS S120 Chassis Format Units including Operating Instructions, List Manuals and the Engineering Manual.

Information is available in the following formats:

- PDF file
- On the SINAMICS Manual Collection (DVD-ROM)
- Configuring documents/documentation available for downloading at:

<https://support.industry.siemens.com/cs/ww/en/ps/13231/man>

Application**Explanations for the manuals:**

- **Operating Instructions**
contain all the information needed to install the device and make electrical connections, information about commissioning and a description of the inverter functions
Phases of use: Control cabinet construction, commissioning, operation, maintenance and servicing.
- **Manuals**
contain all the necessary information about the intended use of the components of a system, e.g. technical data, interfaces, dimension drawings, characteristics and possible applications.
Phases of use: Cabinet configuration/setup, circuit diagram configuration/drawing.
- **Engineering Manuals**
contain all the information needed for EMC-compliant installation and for the configuration of control cabinets and drive systems.
Phases of use: Control cabinet configuration/construction.
- **List Manuals**
describe all parameters, function diagrams and faults/alarms for the product/system as well as their meaning and setting options. It contains parameter data and fault/warning descriptions with functional correlations.
Phases of use: Commissioning of components that have already been connected, configuration of system functions, fault cause/diagnostics.
- **Function Manuals**
contain all the relevant information about individual drive functions
Phases of use: Commissioning of components that have already been connected, configuration of system functions.

Services and Documentation

Notes

Appendix



8/2	Certificates of suitability (approvals)
8/3	Software licences
8/5	Article No. index
8/10	Subject index
8/13	Metal surcharges
8/16	Conditions of sale and delivery

Appendix

Certificates of suitability (approvals)













Overview

Many of the products in this Catalog fulfill requirements, e.g. for UL, CSA or FM and are labeled with the corresponding approval designation.

All approvals, certificates, declarations of conformity, test certificates, e.g. CE, UL, Safety Integrated etc. have been performed with the associated system components as they are described in the Catalogs and Configuration Manuals.

The certificates are only valid if the products are used with the described system components, installed according to the Installation Guidelines and used for their intended purpose.

In other cases, the vendor of these products is responsible for arranging for the issue of new certificates.

Test code	Tested by	Device type/ component	Test standard	Product category/ File-No.
UL: Underwriters Laboratories <i>Independent public testing institution in North America</i>				
	UL according to UL standard (for end products)	SINUMERIK	Standard UL 508	E164110
		SIMOTION	Standard UL 508	E164110
	UL according to CSA standard (for end products)	SINAMICS	Standard UL 508C	E192450, E203250, E214113, E253831
		SIMODRIVE	Standard UL 508C	NMMS2/E192450
	UL according to UL and CSA standards (for end products)	Motors	Standard UL 547	E93429
		Line/motor reactors		E257859
	UL according to UL standard (for mounting parts in end products)	Line filters		E1283
		dv/dt filters		E224872
	UL according to CSA standard (for mounting parts in end products)	Sine-wave filters		E219022
		TM15 Terminal Module		E164110
	UL according to UL and CSA standards (for mounting parts in end products)			
TUV: TÜV Rheinland of North America Inc. <i>Independent public testing institution in North America, Nationally Recognized Testing Laboratory (NRTL)</i>				
	TUV according to UL and CSA standards	SIMODRIVE	NRTL Listing according to standard UL 508C	TUV.COM/4335304002
CSA: Canadian Standards Association <i>Independent public testing institution in Canada</i>				
	CSA according to CSA standard	SINUMERIK	Standard CAN/CSA-C22.2 No. 0-M91/ No. 14-05/No. 142-M1987	LR 102527
FMRC: Factory Mutual Research Corporation <i>Independent public testing institution in North America</i>				
	FM according to FM standard	SINUMERIK	Standard FMRC 3600, FMRC 3611, FMRC 3810 Class I, Div.2, Group A, B, C, D	FM... : 4Y1A7.AX 5B0A2.AX 2D7A2.AX 3007320
EAC: Ivanovo Certificate <i>Independent public testing institution in the Russian Federation</i>				
	EAC in accordance with the EAC Directive	SINAMICS	Standard IEC 61800-5-1 /-2, IEC 61800-3	C2, C3
		SINUMERIK	Standard IEC 61800-5-1 /-2, IEC 61800-3	C2, C3
		SIMOTION	Standard IEC 61800-5-1 /-2, IEC 61800-3	C2, C3
RCM (C-Tick): Australian Communications and Media Authority <i>Independent public testing institution in Australia</i>				
	RCM according to EMC standard	SINAMICS	Standard IEC 61800-3	C2, C3
		SINUMERIK	Standard IEC 61800-3	C2, C3
		SIMOTION	Standard IEC 61800-3	C2, C3
KC: National Radio Research Agency <i>Independent public testing institution in South Korea</i>				
	KC according to EMC standard	SINAMICS	Standard IEC 61800-3	C2
		SINUMERIK	Standard IEC 61800-3	C2
		SIMOTION	Standard IEC 61800-3	C2

Overview

Software types

Software requiring a license is categorized into types. The following software types have been defined:

- Engineering software
- Runtime software

Engineering software

This includes all software products for creating (engineering) user software, e.g. for configuring, programming, parameterizing, testing, commissioning or servicing.

Data generated with engineering software and executable programs can be duplicated for your own use or for use by third-parties free-of-charge.

Runtime software

This includes all software products required for plant/machine operation, e.g. operating system, basic system, system expansions, drivers, etc.

The duplication of the runtime software and executable programs created with the runtime software for your own use or for use by third-parties is subject to a charge.

You can find information about license fees according to use in the ordering data (e.g. in the catalog). Examples of categories of use include per CPU, per installation, per channel, per instance, per axis, per control loop, per variable, etc.

Information about extended rights of use for parameterization/configuration tools supplied as integral components of the scope of delivery can be found in the readme file supplied with the relevant product(s).

License types

Siemens Industry Automation & Drive Technologies offers various types of software license:

- Floating license
- Single license
- Rental license
- Rental floating license
- Trial license
- Demo license
- Demo floating license

Floating license

The software may be installed for internal use on any number of devices by the licensee. Only the concurrent user is licensed. The concurrent user is the person using the program. Use begins when the software is started. A license is required for each concurrent user.

Single license

Unlike the floating license, a single license permits only one installation of the software per license.

The type of use licensed is specified in the ordering data and in the Certificate of License (CoL). Types of use include for example per instance, per axis, per channel, etc.

One single license is required for each type of use defined.

Rental license

A rental license supports the "sporadic use" of engineering software. Once the license key has been installed, the software can be used for a specific period of time (the operating hours do not have to be consecutive).

One license is required for each installation of the software.

Rental floating license

The rental floating license corresponds to the rental license, except that a license is not required for each installation of the software. Rather, one license is required per object (for example, user or device).

Trial license

A trial license supports "short-term use" of the software in a non-productive context, e.g. for testing and evaluation purposes. It can be transferred to another license.

Demo license

The demo license support the "sporadic use" of engineering software in a non-productive context, for example, use for testing and evaluation purposes. It can be transferred to another license. After the installation of the license key, the software can be operated for a specific period of time, whereby usage can be interrupted as often as required.

One license is required per installation of the software.

Demo floating license

The demo floating license corresponds to the demo license, except that a license is not required for each installation of the software. Rather, one license is required per object (for example, user or device).

Certificate of license (CoL)

The CoL is the licensee's proof that the use of the software has been licensed by Siemens. A CoL is required for every type of use and must be kept in a safe place.

Downgrading

The licensee is permitted to use the software or an earlier version/release of the software, provided that the licensee owns such a version/release and its use is technically feasible.

Delivery versions

Software is constantly being updated. The following delivery versions

- PowerPack
- Upgrade

can be used to access updates.

Existing bug fixes are supplied with the ServicePack version.

PowerPack

PowerPacks can be used to upgrade to more powerful software. The licensee receives a new license agreement and CoL (Certificate of License) with the PowerPack. This CoL, together with the CoL for the original product, proves that the new software is licensed.

A separate PowerPack must be purchased for each original license of the software to be replaced.

Upgrade

An upgrade permits the use of a new version of the software on the condition that a license for a previous version of the product is already held.

The licensee receives a new license agreement and CoL with the upgrade. This CoL, together with the CoL for the previous product, proves that the new version is licensed.

A separate upgrade must be purchased for each original license of the software to be upgraded.

Appendix

Software licenses

Overview

ServicePack

ServicePacks are used to debug existing products. ServicePacks may be duplicated for use as prescribed according to the number of existing original licenses.

License key

Siemens Industry Automation & Drive Technologies supplies software products with and without license keys.

The license key serves as an electronic license stamp and is also the "switch" for activating the software (floating license, rental license, etc.).

The complete installation of software products requiring license keys includes the program to be licensed (the software) and the license key (which represents the license).

Software Update Service (SUS)

As part of the SUS contract, all software updates for the respective product are made available to you free of charge for a period of one year from the invoice date. The contract will automatically be extended for one year if it is not canceled three months before it expires.

The possession of the current version of the respective software is a basic condition for entering into an SUS contract.

You can download explanations concerning license conditions from www.siemens.com/automation/salesmaterial-as/catalog/en/terms_of_trade_en.pdf

Article No. index

Article No.	Page	Article No.	Page	Article No.	Page
3KL		3NE		6AU	
3KL5530-1AB01.....	3/97, 3/102	3NE1021-0.....	3/99	6AU1810-1HA23-1XA0.....	6/8
3KL5530-1GB01.....	3/97, 3/102	3NE1022-2.....	5/34	6AU1810-1HA23-1XE0.....	6/8
3KL5730-1AB01.....	3/97, 3/98, 3/102	3NE1224-2.....	5/34	6ES	
3KL5730-1GB01.....	3/97, 3/98, 3/102	3NE1225-2.....	5/34	6ES7901-1BF00-0XA0.....	6/7
3KL6130-1AB02.....	3/97, 3/98, 3/100, 3/102	3NE1227-2.....	5/34	6ES7901-4BD00-0XA0.....	6/7
3KL6130-1GB02.....	3/97, 3/98, 3/100, 3/102	3NE1230-2.....	3/97, 3/99, 3/102, 5/34	6ES7972-0BA42-0XA0.....	3/131, 3/137
3KL6230-1AB02.....	3/98, 3/100, 3/102	3NE1331-2.....	3/97, 3/99, 3/102, 5/34	6ES7972-0BB42-0XA0.....	3/131, 3/137
3KL6230-1GB02.....	3/98, 3/100, 3/102	3NE1333-2.....	3/97, 3/99	6FC	
3NA		3NE1334-2.....	3/99, 3/100, 3/102, 5/34	6FC9341-2AE.....	3/144
3NA3132-6.....	5/34	3NE1435-2.....	3/99, 3/100, 3/102, 5/34	6FC9341-2AF.....	3/144
3NA3136-6.....	5/34	3NE1436-2.....	3/97, 3/99, 3/100, 3/102, 5/34	6FX	
3NA3144.....	3/97	3NE1437-2.....	3/99, 3/100	6FX2002-1DC00-.....	3/176
3NA3240-6.....	5/34	3NE1438-2.....	3/99, 3/102, 5/34	6FX2002-1DC20-.....	3/176
3NA3244-6.....	5/34	3NE1447-2.....	3/99, 3/102, 5/34	6FX5002-2DC00-.....	3/176
3NA3250.....	3/97	3NE1448-2.....	3/100	6FX5002-2DC10-.....	3/176
3NA3250-6.....	3/99	3NE1817-0.....	3/99	6FX5002-2DC20-.....	3/176
3NA3252.....	3/102, 5/34	3NE3224.....	3/110	6FX8002-1AA01-1AB0.....	3/142
3NA3252-6.....	3/99, 5/34	3NE3225.....	3/110	6FX8002-1AA01-1AC0.....	3/142
3NA3254.....	3/97, 3/102, 5/34	3NE3230-0B.....	3/109, 3/110	6FX8002-1AA01-1AD0.....	3/142
3NA3260.....	3/97	3NE3232-0B.....	3/109, 3/110	6FX8002-1AA01-1AE0.....	3/142
3NA3352.....	3/99	3NE3233.....	3/109, 3/110	6FX8002-1AA01-1AF0.....	3/142
3NA3352-6.....	3/102, 5/34	3NE3236.....	3/109	6FX8002-1AA01-1AG0.....	3/142
3NA3354-6.....	3/99, 3/100, 3/102, 5/34	3NE3334-0B.....	3/109	6FX8002-1AA01-1AH0.....	3/142
3NA3360-6.....	3/99, 3/100, 3/102	3NE3335.....	3/109, 3/110	6FX8002-1AA01-1AJ0.....	3/142
3NA3362.....	3/102	3NE3336.....	3/109, 3/110	6FX8002-1AA01-1AK0.....	3/142
3NA3365.....	3/99, 3/100, 3/102, 5/34	3NE3337-8.....	3/110	6FX8002-1AA01-1BA0.....	3/142
3NA3365-6.....	3/99, 3/100, 3/102, 5/34	3NE3338-8.....	3/109	6FX8002-2DC00-.....	3/176
3NA3372.....	3/97, 3/99, 3/100, 3/102, 5/34	3NE3340-8.....	3/109, 3/110	6FX8002-2DC10-.....	3/176
3NA3475.....	3/99, 3/100, 3/102, 5/34	3RT		6FX8002-2DC20-.....	3/176
3NA3480.....	3/100	3RT1034.....	3/99	6GK	
3NA3482.....	3/99, 3/100	3RT1044.....	3/99	6GK1571-1AA00.....	6/7
3NB		3RT1064-6AP36.....	3/97	6GK1901-1BB10-2AA0.....	3/137, 3/145
3NB1126-4KK11.....	3/110	3RT1065-6AP36.....	3/97	6GK1901-1BB10-2AB0.....	3/137, 3/145
3NB1128-4KK11.....	3/110	3RT1066.....	3/98	6GK1901-1BB30-0AA0.....	3/131
3NB1231-4KK11.....	3/109, 3/110	3RT1066-6AP36.....	3/97	6GK1901-1BB30-0AB0.....	3/131
3NB1234-4KK11.....	3/109	3RT1075.....	3/98	6GK1901-1GA00.....	3/131, 3/137, 3/145
3NB1337-4KK11.....	3/109, 3/110	3RT1075-6AP36.....	3/97		
3NB1345-4KK11.....	3/109	3RT1076.....	3/98		
3NB1345-4KK16.....	3/109, 3/110	3RT1076-6AP36.....	3/97		
3NB2345-4KK16.....	3/110	3RT1466-6AP36.....	3/100		
3NB2350-4KK16.....	3/109, 3/110	3RT1476-6AP36.....	3/100, 3/101		
3NB2355-4KK16.....	3/109	3WL			
3NB2357-4KK16.....	3/110	3WL1110-2BB34-4AN2-Z C22.....	3/101		
3NB2364-4KK17.....	3/109, 3/110	3WL1112-2BB34-4AN2-Z C22.....	3/98, 3/101		
3NB2366-4KK17.....	3/110	3WL1116-2BB34-4AN2-Z C22.....	3/98, 3/101		
		3WL1210-4BB34-4AN2-Z C22.....	3/98		
		3WL1210-4CB34-4AN2-Z C22.....	3/100		
		3WL1212-4BB34-4AN2-Z C22.....	3/98		
		3WL1212-4CB34-4AN2-Z C22.....	3/100		
		3WL1216-4BB34-4AN2-Z C22.....	3/98		
		3WL1216-4CB34-4AN2-Z C22.....	3/100		
		3WL1220-2BB34-4AN2-Z C22.....	3/98		
		3WL1220-4BB34-4AN2-Z C22.....	3/98		

Appendix

Article No. index

Article No.	Page	Article No.	Page	Article No.	Page
6SL					
6SL3000-0BE32-5AA0	3/89	6SL3000-2AE38-4AA0	3/111	6SL3040-1LA00-0AA0	3/137
6SL3000-0BE33-1AA0	3/90	6SL3000-2AE41-0AA0	3/111	6SL3040-1LA01-0AA0	3/137
6SL3000-0BE34-4AA0	3/89	6SL3000-2AE41-4AA0	3/111	6SL3040-1MA00-0AA0	3/131
6SL3000-0BE35-0AA0	3/90	6SL3000-2AH31-0AA0	3/111	6SL3040-1MA01-0AA0	3/131
6SL3000-0BE36-0AA0	3/89	6SL3000-2AH31-5AA0	3/111	6SL3053-0AA00-3AA1	3/167
6SL3000-0BE41-2AA0	3/89	6SL3000-2AH31-8AA0	3/111	6SL3054-0E . 0 . -1BA0-Z F01	3/134
6SL3000-0BE41-6AA0	3/89	6SL3000-2AH32-4AA0	3/111	6SL3054-0E . 0 . -1BA0-Z F02	3/134
6SL3000-0BG34-4AA0	3/89	6SL3000-2AH32-6AA0	3/111	6SL3054-0E . 0 . -1BA0-Z F03	3/134
6SL3000-0BG36-0AA0	3/89	6SL3000-2AH33-6AA0	3/111	6SL3054-0E . 00-1BA0	3/134, 3/140
6SL3000-0BG41-2AA0	3/89	6SL3000-2AH34-5AA0	3/111	6SL3054-0E . 00-1BA0-Z F01	3/140
6SL3000-0BG41-6AA0	3/89	6SL3000-2AH34-7AA0	3/111	6SL3054-0E . 01-1BA0	3/134
6SL3000-0CE32-3AA0	3/93	6SL3000-2AH35-8AA0	3/111	6SL3054-0E . 01-1BA0-Z F04	3/134
6SL3000-0CE32-8AA0	3/93	6SL3000-2AH38-1AA0	3/111	6SL3054-0E . 01-1BA0-Z F05	3/134
6SL3000-0CE33-3AA0	3/93	6SL3000-2AH41-0AA0	3/111	6SL3054-0E . 01-1BA0-Z F06	3/134
6SL3000-0CE35-1AA0	3/93	6SL3000-2AH41-1AA0	3/111	6SL3055-0AA00-2CA0	3/144
6SL3000-0CE36-3AA0	3/93	6SL3000-2AH41-3AA0	3/111	6SL3055-0AA00-2EB0	3/145
6SL3000-0CE37-7AA0	3/93	6SL3000-2BE32-1AA0	3/111	6SL3055-0AA00-2TA0	3/150
6SL3000-0CE41-0AA0	3/93	6SL3000-2BE32-6AA0	3/111	6SL3055-0AA00-3AA1	3/154
6SL3000-0CE41-5AA0	3/93	6SL3000-2BE33-2AA0	3/111	6SL3055-0AA00-3BA0	3/160
6SL3000-0CE41-6AA0	3/93	6SL3000-2BE33-8AA0	3/111	6SL3055-0AA00-3FA0	3/152
6SL3000-0CH32-7AA0	3/93	6SL3000-2BE35-0AA0	3/111	6SL3055-0AA00-3KA0	3/163
6SL3000-0CH33-4AA0	3/93	6SL3000-2CE32-3AA0	3/125	6SL3055-0AA00-3LA0	3/165
6SL3000-0CH34-8AA0	3/93	6SL3000-2CE32-8AA	3/125	6SL3055-0AA00-3PA1	3/157
6SL3000-0CH36-0AA0	3/93	6SL3000-2CE33-3AA0	3/125	6SL3055-0AA00-4BA0	3/141
6SL3000-0CH41-2AA0	3/93	6SL3000-2CE34-1AA0	3/125	6SL3055-0AA00-4CA5	3/142
6SL3000-0CH41-6AA0	3/93	6SL3000-2DE32-6AA0	3/116	6SL3055-0AA00-5AA3	3/172
6SL3000-0EE36-2AA0	3/94	6SL3000-2DE32-6EA0	3/121	6SL3055-0AA00-5BA3	3/173
6SL3000-0EE38-8AA0	3/94	6SL3000-2DE35-0AA0	3/116	6SL3055-0AA00-5CA2	3/174
6SL3000-0EE41-4AA0	3/94	6SL3000-2DE35-0EA0	3/121	6SL3055-0AA00-6AA1	3/146
6SL3000-0EH34-7AA0	3/94	6SL3000-2DE38-4AA0	3/116	6SL3055-0AA00-6AB0	3/148
6SL3000-0EH37-6AA0	3/94	6SL3000-2DE38-4EA0	3/121	6SL3060-4AA10-0AA0	3/176
6SL3000-0EH41-4AA0	3/94	6SL3000-2DE41-4AA0	3/116	6SL3060-4AA50-0AA0	3/176
6SL3000-0KE12-2AA0	3/99	6SL3000-2DE41-4EA0	3/121	6SL3060-4AB00-0AA0	3/176
6SL3000-0KH14-0AA0	3/99	6SL3000-2DG31-0EA0	3/121	6SL3060-4AD00-0AA0	3/176
6SL3000-1BE31-3AA0	3/107	6SL3000-2DG31-5EA0	3/121	6SL3060-4AF00-0AA0	3/176
6SL3000-1BE32-5AA0	3/107	6SL3000-2DG32-2EA0	3/121	6SL3060-4AF10-0AA0	3/176
6SL3000-1BE35-0AA0	4/48	6SL3000-2DG33-3EA0	3/121	6SL3060-4AH00-0AA0	3/176
6SL3000-1BE41-0AA0	4/48	6SL3000-2DG34-1EA0	3/121	6SL3060-4AJ20-0AA0	3/176
6SL3000-1BF31-3AA0	3/107	6SL3000-2DG35-8EA0	3/121	6SL3060-4AK00-0AA0	3/176
6SL3000-1BF32-5AA0	3/107	6SL3000-2DG38-1EA0	3/121	6SL3060-4AM00-0AA0	3/176
6SL3000-1BF35-5AA0	4/48	6SL3000-2DG41-3EA0	3/121	6SL3060-4AP00-0AA0	3/176
6SL3000-1BF41-1AA0	4/48	6SL3000-2DH31-0AA0	3/116	6SL3060-4AU00-0AA0	3/176
6SL3000-1BH31-3AA0	3/107	6SL3000-2DH31-5AA0	3/116	6SL3060-4AW00-0AA0	3/176
6SL3000-1BH32-5AA0	3/107	6SL3000-2DH32-2AA0	3/116	6SL3060-4DX04-0AA0	3/169
6SL3000-1BH36-3AA0	4/48	6SL3000-2DH33-3AA0	3/116	6SL3064-1BB00-0AA0	3/131
6SL3000-1BH41-2AA0	4/48	6SL3000-2DH34-1AA0	3/116		
6SL3000-2AE36-1AA0	3/111	6SL3000-2DH35-8AA0	3/116		
		6SL3000-2DH38-1AA0	3/116		
		6SL3000-2DH41-3AA0	3/116		

Article No. index

Article No.	Page	Article No.	Page	Article No.	Page
6SL					
6SL3066-4CA00-0AA0.....	3/11, 3/15, 3/20, 3/25, 3/36, 3/62, 3/66, 3/70, 3/78, 3/131, 3/137, 3/146, 3/152, 3/154, 3/157, 3/160, 3/163, 3/165	6SL3320-1TE33-8AA3.....	3/36	6SL3325-1TG37-4AA3.....	3/78
6SL3066-4CA01-0AA0.....	3/148	6SL3320-1TE35-0AA3.....	3/36	6SL3325-1TG38-0AA3.....	3/78
6SL3070-0AA00-0AG0.....	6/4	6SL3320-1TE36-1AA3.....	3/36	6SL3325-1TG38-1AA3.....	3/78
6SL3072-0AA00-0AG0.....	3/131, 3/137, 6/7	6SL3320-1TE37-5AA3.....	3/36	6SL3325-1TG41-0AA3.....	3/78
6SL3074-0AA01-0AA0.....	3/134	6SL3320-1TE38-4AA3.....	3/36	6SL3325-1TG41-3AA3.....	3/78
6SL3074-0AA10-0AA0.....	3/134, 3/140	6SL3320-1TE41-0AA3.....	3/36	6SL3325-1TG41-6AA3.....	3/78
6SL3077-0AA00-0AB0.....	3/134, 6/8	6SL3320-1TE41-2AA3.....	3/36	6SL3330-1TE34-2AA3.....	3/15
6SL3300-1AE31-3AA0.....	3/103	6SL3320-1TE41-4AA3.....	3/36	6SL3330-1TE35-3AA3.....	3/15
6SL3300-1AE32-5AA0.....	3/103	6SL3320-1TG28-5AA3.....	3/36	6SL3330-1TE38-2AA3.....	3/15
6SL3300-1AE32-5BA0.....	3/103	6SL3320-1TG31-0AA3.....	3/36	6SL3330-1TE41-2AA3.....	3/15
6SL3300-1AF31-3AA0.....	3/103	6SL3320-1TG31-2AA3.....	3/36	6SL3330-1TE41-5AA3.....	3/15
6SL3300-1AF32-5AA0.....	3/103	6SL3320-1TG31-5AA3.....	3/36	6SL3330-1TE41-8AA3.....	3/15
6SL3300-1AF32-5BA0.....	3/103	6SL3320-1TG31-8AA3.....	3/36	6SL3330-1TG33-0AA3.....	3/15
6SL3300-1AH31-3AA0.....	3/103	6SL3320-1TG32-2AA3.....	3/36	6SL3330-1TG34-3AA3.....	3/15
6SL3300-1AH32-5AA0.....	3/103	6SL3320-1TG32-6AA3.....	3/36	6SL3330-1TG36-8AA3.....	3/15
6SL3300-1AH32-5BA0.....	3/103	6SL3320-1TG33-3AA3.....	3/36	6SL3330-1TG41-1AA3.....	3/15
6SL3300-7TE32-6AA0.....	3/30	6SL3320-1TG34-1AA3.....	3/36	6SL3330-1TG41-4AA3.....	3/15
6SL3300-7TE33-8AA0.....	3/30	6SL3320-1TG34-7AA3.....	3/36	6SL3330-1TG41-8AA3.....	3/15
6SL3300-7TE35-0AA0.....	3/30, 3/74	6SL3320-1TG35-8AA3.....	3/36	6SL3330-6TE35-5AA3.....	3/20
6SL3300-7TE38-4AA0.....	3/30, 3/74	6SL3320-1TG37-4AA3.....	3/36	6SL3330-6TE37-3AA3.....	3/20
6SL3300-7TE41-4AA0.....	3/30	6SL3320-1TG38-1AA3.....	3/36	6SL3330-6TE41-1AA3.....	3/20
6SL3300-7TG35-8AA0.....	3/30, 3/74	6SL3320-1TG38-8AA3.....	3/36	6SL3330-6TE41-3AA3.....	3/20
6SL3300-7TG37-4AA0.....	3/30	6SL3320-1TG41-0AA3.....	3/36	6SL3330-6TE41-7AA3.....	3/20
6SL3300-7TG41-3AA0.....	3/30, 3/74	6SL3320-1TG41-3AA3.....	3/36	6SL3330-6TG35-5AA3.....	3/20
6SL3305-7TE41-4AA3.....	3/74	6SL3325-1TE32-1AA3.....	3/78	6SL3330-6TG38-8AA3.....	3/20
6SL3305-7TG37-4AA3.....	3/74	6SL3325-1TE32-6AA3.....	3/78	6SL3330-6TG41-2AA3.....	3/20
6SL3305-7TG41-0AA3.....	3/74	6SL3325-1TE33-1AA3.....	3/78	6SL3330-6TG41-7AA3.....	3/20
6SL3305-7TG41-3AA3.....	3/74	6SL3325-1TE35-0AA3.....	3/78	6SL3330-7TE32-1AA3.....	3/25
6SL3305-7TG41-6AA3.....	3/74	6SL3325-1TE36-1AA3.....	3/78	6SL3330-7TE32-6AA3.....	3/25
6SL3310-1TE32-1AA3.....	3/11	6SL3325-1TE37-5AA3.....	3/78	6SL3330-7TE33-8AA3.....	3/25
6SL3310-1TE32-6AA3.....	3/11	6SL3325-1TE38-4AA3.....	3/78	6SL3330-7TE35-0AA3.....	3/25
6SL3310-1TE33-1AA3.....	3/11	6SL3325-1TE41-0AA3.....	3/78	6SL3330-7TE36-1AA3.....	3/25
6SL3310-1TE33-8AA3.....	3/11	6SL3325-1TE41-2AA3.....	3/78	6SL3330-7TE37-5AA3.....	3/25
6SL3310-1TE35-0AA3.....	3/11	6SL3325-1TE41-4AA3.....	3/78	6SL3330-7TE38-4AA3.....	3/25
6SL3315-1TE32-1AA3.....	3/62	6SL3325-1TE41-4AS3.....	3/78	6SL3330-7TE41-0AA3.....	3/25
6SL3315-1TE32-6AA3.....	3/62	6SL3325-1TG31-0AA3.....	3/78	6SL3330-7TE41-2AA3.....	3/25
6SL3315-1TE33-1AA3.....	3/62	6SL3325-1TG31-5AA3.....	3/78	6SL3330-7TE41-4AA3.....	3/25
6SL3315-1TE35-0AA3.....	3/62	6SL3325-1TG32-2AA3.....	3/78	6SL3330-7TG35-8AA3.....	3/25
6SL3320-1TE32-1AA3.....	3/36	6SL3325-1TG33-3AA3.....	3/78	6SL3330-7TG37-4AA3.....	3/25
6SL3320-1TE32-6AA3.....	3/36	6SL3325-1TG34-7AA3.....	3/78	6SL3330-7TG41-0AA3.....	3/25
6SL3320-1TE33-1AA3.....	3/36	6SL3325-1TG35-8AA3.....	3/78	6SL3330-7TG41-3AA3.....	3/25
				6SL3335-1TE37-4AA3.....	3/66
				6SL3335-1TE41-2AA3.....	3/66
				6SL3335-1TE41-7AA3.....	3/66

Appendix

Article No. index

Article No.	Page	Article No.	Page	Article No.	Page
6SL					
6SL3335-1TG34-2AA3	3/66	6SL3700-1AE35-0AA3	4/48	6SL3710-7LG41-0AA3	5/3
6SL3335-1TG37-3AA3	3/66	6SL3700-1AE41-0AA3	4/48	6SL3710-7LG41-3AA3	5/3
6SL3335-1TG41-3AA3	3/66	6SL3700-1AF35-5AA3	4/48	6SL3720-1TE21-0AB3	4/37
6SL3335-1TG41-7AA3	3/66	6SL3700-1AF41-1AA3	4/48	6SL3720-1TE21-8AB3	4/37
6SL3335-7TE35-0AA3	3/70	6SL3700-1AH36-3AA3	4/48	6SL3720-1TE23-0AB3	4/37
6SL3335-7TE36-1AA3	3/70	6SL3700-1AH41-2AA3	4/48	6SL3720-1TE24-5AB3	4/37
6SL3335-7TE38-4AA3	3/70	6SL3705-0RE23-2AA3	4/79	6SL3720-1TE26-0AB3	4/37
6SL3335-7TE41-0AA3	3/70	6SL3705-0RE24-8AA3	4/79	6SL3720-1TE28-5AB3	4/37
6SL3335-7TE41-4AA3	3/70	6SL3705-0RE27-2AA3	4/79	6SL3720-1TE31-3AB3	4/37
6SL3335-7TG35-8AA3	3/70	6SL3705-0RE31-1AA3	4/79	6SL3720-1TE32-1AA3	4/41
6SL3335-7TG37-4AA3	3/70	6SL3705-0RG23-2AA3	4/79	6SL3720-1TE32-6AA3	4/41
6SL3335-7TG38-1AA3	3/70	6SL3705-0RG24-8AA3	4/79	6SL3720-1TE33-1AA3	4/41
6SL3335-7TG41-0AA3	3/70	6SL3705-0RG27-2AA3	4/79	6SL3720-1TE33-8AA3	4/41
6SL3335-7TG41-3AA3	3/70	6SL3705-0RG31-1AA3	4/79	6SL3720-1TE35-0AA3	4/41
6SL3335-7TG41-6AA3	3/70	6SL3710-7LE32-1AA3	5/3	6SL3720-1TE36-1AA3	4/41
6SL3355-2DX00-1AA0	3/169	6SL3710-7LE32-6AA3	5/3	6SL3720-1TE37-5AA3	4/41
6SL3366-2NG00-0AA0	3/103	6SL3710-7LE33-1AA3	5/3	6SL3720-1TE38-4AA3	4/41
6SL3700-0LE32-5AA3	4/16	6SL3710-7LE33-8AA3	5/3	6SL3720-1TE41-0AA3	4/41
6SL3700-0LE34-0AA3	4/16	6SL3710-7LE35-0AA3	5/3	6SL3720-1TE41-2AA3	4/41
6SL3700-0LE36-3AA3	4/16	6SL3710-7LE36-1AA3	5/3	6SL3720-1TE41-4AA3	4/41
6SL3700-0LE38-0AA3	4/16	6SL3710-7LE37-5AA3	5/3	6SL3720-1TG28-5AA3	4/41
6SL3700-0LE41-0AA3	4/16	6SL3710-7LE38-4AA3	5/3	6SL3720-1TG31-0AA3	4/41
6SL3700-0LE41-3AA3	4/16	6SL3710-7LE41-0AA3	5/3	6SL3720-1TG31-2AA3	4/41
6SL3700-0LE41-6AA3	4/16	6SL3710-7LE41-2AA3	5/3	6SL3720-1TG31-5AA3	4/41
6SL3700-0LE42-0AA3	4/16	6SL3710-7LE41-4AA3	5/3	6SL3720-1TG31-8AA3	4/41
6SL3700-0LE42-0BA3	4/16	6SL3710-7LG28-5AA3	5/3	6SL3720-1TG32-2AA3	4/41
6SL3700-0LE42-5BA3	4/16	6SL3710-7LG31-0AA3	5/3	6SL3720-1TG32-6AA3	4/41
6SL3700-0LE43-2BA3	4/16	6SL3710-7LG31-2AA3	5/3	6SL3720-1TG33-3AA3	4/41
6SL3700-0LG32-8AA3	4/16	6SL3710-7LG31-5AA3	5/3	6SL3720-1TG34-1AA3	4/41
6SL3700-0LG34-0AA3	4/16	6SL3710-7LG31-8AA3	5/3	6SL3720-1TG34-7AA3	4/41
6SL3700-0LG36-3AA3	4/16	6SL3710-7LG32-2AA3	5/3	6SL3720-1TG35-8AA3	4/41
6SL3700-0LG38-0AA3	4/16	6SL3710-7LG32-6AA3	5/3	6SL3720-1TG37-4AA3	4/41
6SL3700-0LG41-0AA3	4/16	6SL3710-7LG33-3AA3	5/3	6SL3720-1TG38-1AA3	4/41
6SL3700-0LG41-3AA3	4/16	6SL3710-7LG34-1AA3	5/3	6SL3720-1TG38-8AA3	4/41
6SL3700-0LG41-6AA3	4/16	6SL3710-7LG34-7AA3	5/3	6SL3720-1TG41-0AA3	4/41
6SL3700-0LG42-0BA3	4/16	6SL3710-7LG35-8AA3	5/3	6SL3720-1TG41-3AA3	4/41
6SL3700-0LG42-5BA3	4/16	6SL3710-7LG37-4AA3	5/3	6SL3720-1TX38-0AA3	4/37
6SL3700-0LG43-2BA3	4/16	6SL3710-7LG38-1AA3	5/3	6SL3720-1TX41-2AA3	4/37
6SL3700-0MX14-0AA3	4/52	6SL3710-7LG38-8AA3	5/3	6SL3725-1TE36-1AA3	4/73
6SL3700-0MX16-3AA3	4/52			6SL3725-1TE37-5AA3	4/73
6SL3700-0MX21-0AA3	4/52			6SL3725-1TE38-4AA3	4/73
6SL3700-0MX21-4AA3	4/52			6SL3725-1TE41-0AA3	4/73
				6SL3725-1TE41-2AA3	4/73
				6SL3725-1TE41-4AA3	4/73
				6SL3725-1TE41-4AS3	4/73

Article No. index

Article No.	Page	Article No.	Page	Article No.	Page
6SL		6SL		6SW	
6SL3725-1TG34-7AA3	4/73	6SL3730-6TG38-8AA3	4/27	6SW1700-0JD00-0AB2	6/10
6SL3725-1TG35-8AA3	4/73	6SL3730-6TG38-8BA3	4/27	6SW1700-0JD01-0AB2	6/10
6SL3725-1TG37-4AA3	4/73	6SL3730-6TG38-8BC3	4/27	6SW1700-5JA00-5AA0	6/10
6SL3725-1TG38-0AA3	4/73	6SL3730-6TG41-2AA3	4/27	6SW1700-5JA00-5AA1	6/10
6SL3725-1TG38-8AA3	4/73	6SL3730-6TG41-2BA3	4/27	6SW1700-5JA00-5AA4	6/10
6SL3725-1TG41-0AA3	4/73	6SL3730-6TG41-2BC3	4/27	6SW1700-5JD00-1AC0	6/10
6SL3725-1TG41-3AA3	4/73	6SL3730-6TG41-7AA3	4/27	6SW1700-7JD00-0AA0	6/10
6SL3725-1TG41-6AA3	4/73	6SL3730-6TG41-7BA3	4/27	6SW1700-7JD00-1AA0	6/10
6SL3730-1TE34-2AA3	4/23	6SL3730-6TG41-7BC3	4/27	6SW1700-7JD00-1AA4	6/10
6SL3730-1TE35-3AA3	4/23	6SL3730-7TE32-1BA3	4/32	6SW1700-8JD00-0AA0	6/10
6SL3730-1TE38-2AA3	4/23	6SL3730-7TE32-6BA3	4/32	6SW1700-8JD00-0AA4	6/10
6SL3730-1TE41-2AA3	4/23	6SL3730-7TE33-8BA3	4/32	6SW1700-8JD00-1AA0	6/10
6SL3730-1TE41-2BA3	4/23	6SL3730-7TE35-0BA3	4/32	6SW1700-8JD00-1AA4	6/10
6SL3730-1TE41-2BC3	4/23	6SL3730-7TE36-1BA3	4/32	6SW1700-8JD01-0AA0	6/10
6SL3730-1TE41-5AA3	4/23	6SL3730-7TE38-4BA3	4/32	6SW1700-8JD01-0AA4	6/10
6SL3730-1TE41-5BA3	4/23	6SL3730-7TE41-0BA3	4/32	6SW1700-8JD01-1AA0	6/10
6SL3730-1TE41-5BC3	4/23	6SL3730-7TE41-0BC3	4/32	6SW1700-8JD01-1AA4	6/10
6SL3730-1TE41-8AA3	4/23	6SL3730-7TE41-4BA3	4/32		
6SL3730-1TE41-8BA3	4/23	6SL3730-7TE41-4BC3	4/32	6XV	
6SL3730-1TE41-8BC3	4/23	6SL3730-7TG35-8BA3	4/32	6XV1840-2AH10	3/131, 3/137, 3/145
6SL3730-1TG33-0AA3	4/23	6SL3730-7TG37-4BA3	4/32	6XV1840-3AH10	3/131, 3/137, 3/145
6SL3730-1TG34-3AA3	4/23	6SL3730-7TG37-4BC3	4/32	6XV1840-4AH10	3/131, 3/137, 3/145
6SL3730-1TG36-8AA3	4/23	6SL3730-7TG41-0BA3	4/32	6XV1870-2B	3/131, 3/137, 3/145
6SL3730-1TG41-1AA3	4/23	6SL3730-7TG41-0BC3	4/32	6XV1870-2D	3/131, 3/137, 3/145
6SL3730-1TG41-1BA3	4/23	6SL3730-7TG41-3BA3	4/32		
6SL3730-1TG41-1BC3	4/23	6SL3730-7TG41-3BC3	4/32	9LD	
6SL3730-1TG41-4AA3	4/23	6SL3735-1TE37-4LA3	4/65	9LD1730-0AA24	7/9
6SL3730-1TG41-4BA3	4/23	6SL3735-1TE41-2LA3	4/65	9LD1730-0AA30	7/9
6SL3730-1TG41-4BC3	4/23	6SL3735-1TE41-7LA3	4/65	9LD1730-0AA36	7/9
6SL3730-1TG41-8AA3	4/23	6SL3735-1TG34-2LA3	4/65	9LD1730-0AA42	7/9
6SL3730-1TG41-8BA3	4/23	6SL3735-1TG37-3LA3	4/65	9LD1730-0AA48	7/9
6SL3730-1TG41-8BC3	4/23	6SL3735-1TG41-3LA3	4/65	9LD1730-0AA60	7/9
6SL3730-6TE35-5AA3	4/27	6SL3735-1TG41-7LA3	4/65		
6SL3730-6TE37-3AA3	4/27	6SL3735-7TE41-0LA3	4/69	E86060	
6SL3730-6TE41-1AA3	4/27	6SL3735-7TE41-4LA3	4/69	E86060-D4001-A500-D4	6/3
6SL3730-6TE41-1BA3	4/27	6SL3735-7TG41-0LA3	4/69		
6SL3730-6TE41-1BC3	4/27	6SL3735-7TG41-3LA3	4/69	SAX	
6SL3730-6TE41-3AA3	4/27	6SL3735-7TG41-6LA3	4/69	SAX31	3/62, 3/66, 3/70, 3/78
6SL3730-6TE41-3BA3	4/27	6SL3760-0MB00-0AA0	3/90	SAX61.../SAX81	3/62, 3/66, 3/70, 3/78
6SL3730-6TE41-3BC3	4/27	6SL3760-0MC00-0AA0	3/90		
6SL3730-6TE41-7AA3	4/27	6SL3760-0ME00-0AA0	3/90	VXF	
6SL3730-6TE41-7BA3	4/27	6SL3760-0MG00-0AA0	3/90	VXF41.../VXF41	3/62, 3/66, 3/70, 3/78
6SL3730-6TE41-7BC3	4/27	6SL3760-0MN00-0AA0	3/90		
6SL3730-6TG35-5AA3	4/27	6SL3766-1FA00-0AA0	3/53, 4/106, 5/37		
		6SL3780-0AA00-0AA0	4/107		
		6SL3780-0AC00-0AA0	4/107		
		6SL3780-0AE00-0AA0	4/107		
		6SL3780-0AJ00-0AA0	4/107		
		6SL3780-0AK00-0AA0	6/12		

Appendix

Subject index

	Page		Page
A		D	
Active Interface Modules, SINAMICS S120 chassis format		DC link components	3/103
• Air-cooled units	3/30	Derating data	3/8, 4/12, 4/14, 5/15
• Liquid-cooled units	3/74	Description of the options	4/91, 5/22
Active Line Connection Modules	4/69	Documentation	7/15
Active Line Modules, incl. Active Interface Modules	4/31	Download center	7/4
Active Line Modules, SINAMICS S120 chassis format		Drive Control Chart (SINAMICS DCC)	6/8
• Air-cooled units	3/25	Drive ES Engineering Software	6/9
• Liquid-cooled units	3/70	Drive Technology Configurator	6/3
Air-cooled units		DRIVE-CLiQ Hub Module	
• SINAMICS S120 Cabinet Modules	4/8	• DMC20	3/146
• SINAMICS S120 converter built-in units chassis format	3/6	• DME20	3/148
AOP30 Advanced Operator Panel	3/142, 4/94, 5/6	DRIVE-CLiQ signal cables	3/175
Applications	1/6	dv/dt filters compact plus VPL	3/120
Approvals	8/2	dv/dt filters plus VPL	3/115
Auxiliary Power Supply Modules	4/52	E	
B		Encoder system connection	3/171
Basic Functions	2/10	Energy efficiency	1/3
Basic Line Connection Modules	4/65	Engineering Manual	6/14
Basic Line Modules, SINAMICS S120 Cabinet Modules		Engineering procedure	6/13
• Air-cooled units	4/22	EPLAN	6/11
Basic Line Modules, SINAMICS S120 chassis format		EtherNet/IP	2/23
• Air-cooled units	3/15	Extended Functions	2/10
• Liquid-cooled units	3/66	Extension of liability for defects	7/9
BOP20 Basic Operator Panel	3/141	F	
Braking Modules	3/103	Field Services	7/7
Braking resistors	3/107	Filter	
C		• dv/dt filters compact plus VPL	3/120
Cable cross-sections and connections	5/35	• dv/dt filters plus VPL	3/115
CANopen	2/23	• Line filters	3/89
CBC10 Communication Board	3/144, 4/92, 5/23	• Sine-wave filters	3/125
CBE20 Communication Board	3/145, 4/92, 5/23		
Central Braking Modules	4/48		
Communication overview	2/15		
CompactFlash card			
• for CU310-2	3/140		
• for CU320-2	3/134		
Conditions of sale and delivery	8/14		
Configuring with EPLAN	6/11		
Connection system	3/175		
Consulting Services	7/6		
Control Units	3/127		
• CU310-2	3/136		
• CU320-2	3/130		
Converter selection	1/7		
Customer terminal block -X55	4/55		
Customized solutions	4/108		

	Page		Page
H			
Heat Exchanger Modules	4/79		
I			
Identification of spare parts on the Internet	7/13		
Industrial Ethernet	2/17		
Industry Services	7/5		
Information and Download Center, Social media, Mobile media	7/4		
Information and ordering options on the Internet and on DVD	7/3		
Integrated Drive Systems	8		
Integration in automation	1/2		
Interactive Catalog CA 01	6/3		
L			
Line Connection Modules	4/15		
Line filters	3/89		
Line reactors	3/93		
Line-side components - Recommended fuses	5/34		
Line-side power components	3/88		
Liquid-cooled units			
• SINAMICS S120 Cabinet Modules	4/58		
• SINAMICS S120 converter built-in units chassis format	3/54		
M			
Maintenance Services	7/7		
Metal surcharges	8/11		
Mobile media	7/4		
Modbus RTU and USS	2/23		
Modernization Services	7/8		
MOTION-CONNECT signal cables	3/175		
Motor Modules SINAMICS S120			
• Chassis format, air-cooled units	3/36		
• Chassis format, liquid-cooled units	3/78		
• Cabinet Modules, air-cooled units booksize	4/37		
• Cabinet Modules, air-cooled units chassis	4/41		
• Cabinet Modules, liquid-cooled units	4/73		
Motor reactors	3/111		
Motor-side power components	3/111		
Mounting device for power blocks	3/53, 4/106, 5/37		
My Documentation Manager	7/14		
O			
Online Services	7/3		
Online Support	7/8		
Option selection matrix	4/89, 4/107		
Options	4/83, 5/18		
Ordering options on the Internet and on DVD	7/3		
Order-specific integration engineering	4/107		
Overload capability	3/10, 3/61, 4/14, 4/64, 5/17		
Overview of Safety Integrated functions	2/14		
P			
Partners at Siemens	7/2		
Plant Data Services	7/6		
Platform concept	1/4		
Power Modules, SINAMICS S120 chassis format			
• Air-cooled units	3/6		
• Liquid-cooled units	3/62		
PROFIBUS	2/16		
PROFIdrive	2/22		
PROFINET	2/18		
Q			
Quality management according to EN ISO 9001	1/4		
R			
Reactors			
• Line reactors	3/93		
• Motor reactors	3/111		
Recommended line-side system components	3/97		
Repair Services	7/7		
Retrofit Services	7/7		
S			
Safe actual value sensing with or without encoders	2/10		
Safe Brake Adapter SBA	3/169		
Safe Brake Control (SBC)	2/5		
Safe Brake Test (SBT)	2/6		
Safe Direction (SDI)	2/7		
Safe Operating Stop (SOS)	2/5		
Safe Position (SP)	2/8		
Safe Speed Monitor (SSM)	2/7		
Safe Stop 1 (SS1)	2/4		
Safe Stop 2 (SS2)	2/4		
Safe Torque Off (STO)	2/3		
Safety Integrated	2/2		
Safely Limited Position (SLP)	2/8		
Safely-Limited Speed (SLS)	2/6		
Security information	6/1		
Selection guide SINAMICS	1/7		
Sensor Module Cabinet-Mounted			
• SMC10	3/172		
• SMC20	3/173		
• SMC30	3/174		
Service Programs and Agreements	7/7		
Service & Support	7/9		
Signal cables	3/175		

Appendix

Subject index

	Page		Page
S		T	
SIMOTICS motors	1/8	Terminal Board TB30	3/150
SINAMICS drive family	1/2	Terminal Module	
SinaSave energy efficiency tool	6/2	• TM120	3/163
SINAMICS Drive Control Chart (SINAMICS DCC)	6/8	• TM15	3/152
SINAMICS selection guide	1/7	• TM150	3/165
SINAMICS S120 Cabinet Modules		• TM31	3/154
• Air-cooled units	4/8	• TM41	3/157
• Liquid-cooled units	4/58	• TM54F	3/160
SINAMICS S120 converter built-in units chassis format		The SINAMICS drive family	1/2
• Air-cooled units	3/6	Totally Integrated Automation and communication	1/2
• Liquid-cooled units	3/54	Training	7/6, 7/11
SINAMICS S150 converter cabinet units	5/1	Training courses	7/12
Sine-wave filters	3/125	U	
SITRAIN	7/11	USS and Modbus RTU	2/23
SIZER for Siemens Drives engineering tool	6/4	V	
SIZER WEB ENGINEERING engineering tool	6/5	Voltage Sensing Module VSM10	3/167
Smart Line Modules			
• SINAMICS S120 Cabinet Modules, air-cooled units	4/27		
• SINAMICS S120 chassis format, air-cooled units	3/20		
Social media	7/4		
Software licenses	8/3		
Spare Parts Services	7/6		
SPARES on Web	7/13		
STARTER commissioning tool	6/6		
Support	7/9		
Support app	7/8		
Support Services	7/6		

Explanation of the raw material/metal surcharges¹⁾

Surcharge calculation

To compensate for variations in the price of the raw materials silver, copper, aluminum, lead, gold, dysprosium²⁾ and/or neodym²⁾, surcharges are calculated on a daily basis using the so-called metal factor for products containing these raw materials. A surcharge for the respective raw material is calculated as a supplement to the price of a product if the basic official price of the raw material in question is exceeded.

The surcharges are calculated in accordance with the following criteria:

- Basic official price of the raw material
Basic official price from the day prior to receipt of the order or prior to release order (daily price) for³⁾
 - Silver (sales price, processed)
 - Gold (sales price, processed)
 and for⁴⁾
 - Copper (lower DEL notation + 1 %)
 - Aluminum (aluminum in cables)
 - Lead (lead in cables)
- Metal factor of the products
Certain products are displayed with a metal factor. The metal factor determines the official price (for those raw materials concerned) as of which the metal surcharges are applied and the calculation method used (weight or percentage method). An exact explanation is given below.

Structure of the metal factor

The metal factor consists of several digits; the first digit indicates whether the percentage method of calculation refers to the list price or a possible discounted price (customer net price) (L = list price / N = customer net price).

The remaining digits indicate the method of calculation used for the respective raw material. If no surcharge is added for a raw material, a "-" is used.

1st digit	List or customer net price using the percentage method
2nd digit	for silver (AG)
3rd digit	for copper (CU)
4th digit	for aluminum (AL)
5th digit	for lead (PB)
6th digit	for gold (AU)
7th digit	for dysprosium (Dy) ²⁾
8th digit	for neodym (Nd) ²⁾

Weight method

The weight method uses the basic official price, the daily price and the raw material weight. In order to calculate the surcharge, the basic official price must be subtracted from the daily price. The difference is then multiplied by the raw material weight.

The basic official price can be found in the table below using the number (1 to 9) of the respective digit of the metal factor. The raw material weight can be found in the respective product descriptions.

Percentage method

Use of the percentage method is indicated by the letters A-Z at the respective digit of the metal factor.

The surcharge is increased - dependent on the deviation of the daily price compared with the basic official price - using the percentage method in "steps" and consequently offers surcharges that remain constant within the framework of this "step range". A higher percentage rate is charged for each new step. The respective percentage level can be found in the table below.

Metal factor examples

L E A - - - - -	Basis for % surcharge: List price Silver Basis 150 €, Step 50 €, 0.5 % Copper Basis 150 €, Step 50 €, 0.1 % No surcharge for aluminum No surcharge for lead No surcharge for gold No surcharge for dysprosium No surcharge for neodym
N - A 6 - - - - -	Basis for % surcharge: Customer net price No surcharge for silver Copper Basis 150 €, Step 50 €, 0.1 % Aluminum acc. to weight, basic offic. price 225 € No surcharge for lead No surcharge for gold No surcharge for dysprosium No surcharge for neodym
- - 3 - - - - -	No basis necessary No surcharge for silver Copper acc. to weight, basic official price 150 € No surcharge for aluminum No surcharge for lead No surcharge for gold No surcharge for dysprosium No surcharge for neodym

¹⁾ Refer to the separate explanation on the next page regarding the raw materials dysprosium and neodym (= rare earths).

²⁾ For a different method of calculation, refer to the separate explanation for these raw materials on the next page.

³⁾ Source: Umicore, Hanau (www.metalsmanagement.umicore.com).

⁴⁾ Source: Schutzvereinigung DEL-Notiz e.V. (www.del-notiz.org).

Appendix

Metal surcharges

Explanation of the raw material/metal surcharges for dysprosium and neodym (rare earths)

Surcharge calculation

To compensate for variations in the price of the raw materials silver¹⁾, copper¹⁾, aluminum¹⁾, lead¹⁾, gold¹⁾, dysprosium and/or neodym, surcharges are calculated on a daily basis using the so-called metal factor for products containing these raw materials. The surcharge for dysprosium and neodym is calculated as a supplement to the price of a product if the basic official price of the raw material in question is exceeded.

The surcharge is calculated in accordance with the following criteria:

- Basic official price of the raw material²⁾
Three-month basic average price (see below) in the period before the quarter in which the order was received or the release order took place (= average official price) for
- dysprosium (Dy metal, 99 % min. FOB China; USD/kg)
- neodym (Nd metal, 99 % min. FOB China; USD/kg)
- Metal factor of the products
Certain products are displayed with a metal factor. The metal factor indicates (for those raw materials concerned) the basic official price as of which the surcharges for dysprosium and neodym are calculated using the weight method. An exact explanation of the metal factor is given below.

Three-month average price

The prices of rare earths vary according to the foreign currency, and there is no freely accessible stock exchange listing. This makes it more difficult for all parties involved to monitor changes in price. In order to avoid continuous adjustment of the surcharges, but to still ensure fair, transparent pricing, an average price is calculated over a three-month period using the average monthly foreign exchange rate from USD to EUR (source: European Central Bank). Since not all facts are immediately available at the start of each month, a one-month buffer is allowed before the new average price applies.

Examples of calculation of the average official price:

Period for calculation of the average price:	Period during which the order/release order is effected and the average price applies:
Sep 2012 - Nov 2012	Q1 in 2013 (Jan - Mar)
Dec 2012 - Feb 2013	Q2 in 2013 (Apr - Jun)
Mar 2013 - May 2013	Q3 in 2013 (Jul - Sep)
Jun 2013 - Aug 2013	Q4 in 2013 (Oct - Dec)

Structure of the metal factor

The metal factor consists of several digits; the first digit is not relevant to the calculation of dysprosium and neodym.

The remaining digits indicate the method of calculation used for the respective raw material. If no surcharge is added for a raw material, a "-" is used.

1st digit	List or customer net price using the percentage method
2nd digit	for silver (AG) ¹⁾
3rd digit	for copper (CU) ¹⁾
4th digit	for aluminum (AL) ¹⁾
5th digit	for lead (PB) ¹⁾
6th digit	for gold (AU) ¹⁾
7th digit	for dysprosium (Dy)
8th digit	for neodym (Nd)

Weight method

The weight method uses the basic official price, the average price and the raw material weight. In order to calculate the surcharge, the basic official price must be subtracted from the average price. The difference is then multiplied by the raw material weight.

The basic official price can be found in the table below using the number (1 to 9) of the respective digit of the metal factor. Your Sales contact can inform you of the raw material weight.

Metal factor examples

-----71	No basis necessary
↑	No surcharge for silver
↑	No surcharge for copper
↑	No surcharge for aluminum
↑	No surcharge for lead
↑	No surcharge for gold
↑	Dysprosium acc. to weight, basic official price 300 €
↑	Neodym acc. to weight, basic official price 50 €

¹⁾ For a different method of calculation, refer to the separate explanation for these raw materials on the previous page.

²⁾ Source: Asian Metal Ltd (www.asianmetal.com)

Values of the metal factor

Percentage method	Basic official price in €	Step range in €	% surcharge 1st step	% surcharge 2nd step	% surcharge 3rd step	% surcharge 4th step	% surcharge per additional step	
			Price in € 150.01 - 200.00	Price in € 200.01 - 250.00	Price in € 250.01 - 300.00	Price in € 300.01 - 350.00		
A	150	50	0.1	0.2	0.3	0.4	0.1	
B	150	50	0.2	0.4	0.6	0.8	0.2	
C	150	50	0.3	0.6	0.9	1.2	0.3	
D	150	50	0.4	0.8	1.2	1.6	0.4	
E	150	50	0.5	1.0	1.5	2.0	0.5	
F	150	50	0.6	1.2	1.8	2.4	0.6	
G	150	50	1.0	2.0	3.0	4.0	1.0	
H	150	50	1.2	2.4	3.6	4.8	1.2	
I	150	50	1.6	3.2	4.8	6.4	1.6	
J	150	50	1.8	3.6	5.4	7.2	1.8	
			175.01 - 225.00	225.01 - 275.00	275.01 - 325.00	325.01 - 375.00		
O	175	50	0.1	0.2	0.3	0.4	0.1	
P	175	50	0.2	0.4	0.6	0.8	0.2	
R	175	50	0.5	1.0	1.5	2.0	0.5	
			225.01 - 275.00	275.01 - 325.00	325.01 - 375.00	375.01 - 425.00		
S	225	50	0.2	0.4	0.6	0.8	0.2	
U	225	50	1.0	2.0	3.0	4.0	1.0	
V	225	50	1.0	1.5	2.0	3.0	1.0	
W	225	50	1.2	2.5	3.5	4.5	1.0	
			150.01 - 175.00	175.01 - 200.00	200.01 - 225.00	225.01 - 250.00		
Y	150	25	0.3	0.6	0.9	1.2	0.3	
			400.01 - 425.00	425.01 - 450.00	450.01 - 475.00	475.01 - 500.00		
Z	400	25	0.1	0.2	0.3	0.4	0.1	
Price basis (1st digit)								
L	Calculation based on the list price							
N	Calculation based on the customer net price (discounted list price)							
Weight method	Basic official price in €							
1	50	Calculation based on raw material weight						
2	100							
3	150							
4	175							
5	200							
6	225							
7	300							
8	400							
9	555							
Miscellaneous								
-	No metal surcharge							

Appendix

Conditions of sale and delivery

1. General Provisions

By using this catalog you can acquire hardware and software products described therein from Siemens AG subject to the following Terms and Conditions of Sale and Delivery (hereinafter referred to as "T&C"). Please note that the scope, the quality and the conditions for supplies and services, including software products, by any Siemens entity having a registered office outside Germany, shall be subject exclusively to the General Terms and Conditions of the respective Siemens entity. The following T&C apply exclusively for orders placed with Siemens Aktiengesellschaft, Germany.

1.1 For customers with a seat or registered office in Germany

For customers with a seat or registered office in Germany, the following applies subordinate to the T&C:

- the "General Terms of Payment"¹⁾ and,
- for software products, the "General License Conditions for Software Products for Automation and Drives for Customers with a Seat or Registered Office in Germany"¹⁾ and,
- for other supplies and services, the "General Conditions for the Supply of Products and Services of the Electrical and Electronics Industry"¹⁾.

1.2 For customers with a seat or registered office outside Germany

For customers with a seat or registered office outside Germany, the following applies subordinate to the T&C:

- the "General Terms of Payment"¹⁾ and,
- for software products, the "General License Conditions for Software Products for Automation and Drives for Customers with a Seat or Registered Office outside of Germany"¹⁾ and
- for other supplies and/or services, the "General Conditions for Supplies of Siemens Industry for Customers with a Seat or Registered Office outside of Germany"¹⁾.

2. Prices

The prices are in € (Euro) ex point of delivery, exclusive of packaging.

The sales tax (value added tax) is not included in the prices. It shall be charged separately at the respective rate according to the applicable statutory legal regulations.

Prices are subject to change without prior notice. We will charge the prices valid at the time of delivery.

To compensate for variations in the price of raw materials (e.g. silver, copper, aluminum, lead, gold, dysprosium and neodym), surcharges are calculated on a daily basis using the so-called metal factor for products containing these raw materials. A surcharge for the respective raw material is calculated as a supplement to the price of a product if the basic official price of the raw material in question is exceeded.

The metal factor of a product indicates the basic official price (for those raw materials concerned) as of which the surcharges on the price of the product are applied, and with what method of calculation.

You will find a detailed explanation of the metal factor on the page headed "Metal surcharges".

To calculate the surcharge (except in the cases of dysprosium and neodym), the official price from the day prior to that on which the order was received or the release order was effected is used.

To calculate the surcharge applicable to dysprosium and neodym ("rare earths"), the corresponding three-month basic average price in the quarter prior to that in which the order was received or the release order was effected is used with a one-month buffer (details on the calculation can be found in the explanation of the metal factor).

3. Additional Terms and Conditions

The dimensions are in mm. In Germany, according to the German law on units in measuring technology, data in inches apply only to devices for export.

Illustrations are not binding.

Insofar as there are no remarks on the individual pages of this catalog - especially with regard to data, dimensions and weights given - these are subject to change without prior notice.

4. Export regulations

We shall not be obligated to fulfill any agreement if such fulfillment is prevented by any impediments arising out of national or international foreign trade or customs requirements or any embargoes and/or other sanctions.

Export of goods listed in this catalog may be subject to licensing requirements. We will indicate in the delivery details whether licenses are required under German, European and US export lists. Goods labeled with "AL" not equal to "N" are subject to European or German export authorization when being exported out of the EU. Goods labeled with "ECCN" not equal to "N" are subject to US re-export authorization.

The export indications can be viewed in advance in the description of the respective goods on the Industry Mall, our online catalog system. Only the export labels "AL" and "ECCN" indicated on order confirmations, delivery notes and invoices are authoritative.

Even without a label, or with label "AL:N" or "ECCN:N", authorization may be required i.a. due to the final disposition and intended use of goods.

If you transfer goods (hardware and/or software and/or technology as well as corresponding documentation, regardless of the mode of provision) delivered by us or works and services (including all kinds of technical support) performed by us to a third party worldwide, you must comply with all applicable national and international (re-)export control regulations.

If required for the purpose of conducting export control checks, you (upon request by us) shall promptly provide us with all information pertaining to the particular end customer, final disposition and intended use of goods delivered by us respectively works and services provided by us, as well as to any export control restrictions existing in this relation.

The products listed in this catalog may be subject to European/German and/or US export regulations. Any export requiring approval is therefore subject to authorization by the relevant authorities.

Errors excepted and subject to change without prior notice.

1) The text of the Terms and Conditions of Siemens AG can be downloaded at www.siemens.com/automation/salesmaterial-as/catalog/en/terms_of_trade_en.pdf

Further information can be obtained from our branch offices listed at www.siemens.com/automation/partner

Interactive Catalog on DVD Products for Automation and Drives	<i>Catalog</i> CA 01	Low-Voltage Power Distribution and Electrical Installation Technology SENTRON · SIVACON · ALPHA Protection, Switching, Measuring and Monitoring Devices, Switchboards and Distribution Systems Standards-Compliant Components for Photovoltaic Plants Electrical Components for the Railway Industry TÜV-certified Power Monitoring System Components for Industrial Control Panels according to UL Standards 3WT Air Circuit Breakers up to 4000 A 3VT Molded Case Circuit Breakers up to 1600 A <i>Digital: SIVACON System Cubicles, System Lighting and System Air-Conditioning</i> <i>Digital: ALPHA Distribution Systems</i> ALPHA FIX Terminal Blocks SIVACON S4 Power Distribution Boards SIVACON 8PS Busbar Trunking Systems <i>Digital: DELTA Switches and Socket Outlets</i>	<i>Catalog</i> LV 10 LV 11 LV 12 LV 14 LV 16 LV 35 LV 36 LV 50 LV 51 LV 52 LV 56 LV 70 ET D1
Building Control GAMMA Building Control	ET G1	Motion Control SINUMERIK 840 Equipment for Machine Tools SINUMERIK 808 Equipment for Machine Tools SINUMERIK 828 Equipment for Machine Tools SIMOTION, SINAMICS S120 & SIMOTICS Equipment for Production Machines <i>Digital: Drive and Control Components for Cranes</i>	NC 62 NC 81.1 NC 82 PM 21 CR 1
Drive Systems SINAMICS G130 Drive Converter Chassis Units SINAMICS G150 Drive Converter Cabinet Units SINAMICS GM150, SINAMICS SM150 Medium-Voltage Converters SINAMICS PERFECT HARMONY GH180 Medium-Voltage Air-Cooled Drives Germany Edition SINAMICS G180 Converters – Compact Units, Cabinet Systems, Cabinet Units Air-Cooled and Liquid-Cooled SINAMICS S120 Chassis Format Units and Cabinet Modules SINAMICS S150 Converter Cabinet Units SINAMICS DCM DC Converter, Control Module SINAMICS DCM Cabinet SINAMICS Inverters for Single-Axis Drives and SIMOTICS Motors SINAMICS G120P and SINAMICS G120P Cabinet pump, fan, compressor converters LOHER VARIO High Voltage Motors Flameproof, Type Series 1PS4, 1PS5, 1MV4 and 1MV5 Frame Size 355 to 1000, Power Range 80 to 7100 kW Three-Phase Induction Motors SIMOTICS HV, SIMOTICS TN • Series H-compact • Series H-compact PLUS High Voltage Three-phase Induction Motors SIMOTICS HV Series A-compact PLUS Three-Phase Induction Motors SIMOTICS HV, Series H-compact Synchronous Motors with Permanent-Magnet Technology, HT-direct DC Motors SIMOREG DC MASTER 6RA70 Digital Chassis Converters SIMOREG K 6RA22 Analog Chassis Converters <i>Digital: SIMOREG DC MASTER 6RM70 Digital Converter Cabinet Units</i> SIMOVERT PM Modular Converter Systems SIEMOSYN Motors MICROMASTER 420/430/440 Inverters MICROMASTER 411/COMBIMASTER 411 <u>Low-Voltage Three-Phase-Motors</u> SIMOTICS Low-Voltage Motors SIMOTICS FD Low-Voltage Motors LOHER Low-Voltage Motors MOTOX Geared Motors SIMOGEAR Geared Motors SIMOGEAR Gearboxes with adapter <u>Mechanical Driving Machines</u> FLENDER Standard Couplings FLENDER High Performance Couplings FLENDER Backlash-free Couplings FLENDER SIP Standard industrial planetary gear units	D 11 D 12 D 15.1 D 18.1 D 21.3 D 23.1 D 23.2 D 31 D 35 D 83.2 D 84.1 D 84.9 D 86.1 D 86.2 DA 12 DA 21.1 DA 21.2 DA 22 DA 45 DA 48 DA 51.2 DA 51.3 D 81.1 D 81.8 D 83.1 D 87.1 MD 50.1 MD 50.11 MD 10.1 MD 10.2 MD 10.3 MD 31.1	Power Supply SITOP Power supply Safety Integrated Safety Technology for Factory Automation SIMATIC HMI / PC-based Automation Human Machine Interface Systems/ PC-based Automation SIMATIC Ident Industrial Identification Systems SIMATIC Industrial Automation Systems Products for Totally Integrated Automation SIMATIC PCS 7 Process Control System System components SIMATIC PCS 7 Process Control System Technology components Add-ons for the SIMATIC PCS 7 Process Control System SIMATIC NET Industrial Communication SIRIUS Industrial Controls <i>Digital: SIRIUS Industrial Controls</i>	KT 10.1 SI 10 ST 80/ ST PC ID 10 ST 70 ST PCS 7 ST PCS 7 T ST PCS 7 AO IK PI IC 10
Process Instrumentation and Analytics <i>Digital: Field Instruments for Process Automation</i> <i>Digital: SIPART Controllers and Software</i> Products for Weighing Technology <i>Digital: Process Analytical Instruments</i> <i>Digital: Process Analytics, Components for Continuous Emission Monitoring</i>	FI 01 MP 31 WT 10 AP 01 AP 11	Information and Download Center Digital versions of the catalogs are available on the Internet at: www.siemens.com/industry/infocenter There you'll find additional catalogs in other languages. Please note the section "Downloading catalogs" on page "Online services" in the appendix of this catalog.	

Get more information

SINAMICS S120

Chassis Format Units and Cabinet Modules:

www.siemens.com/sinamics-s120

SINAMICS S150

Converter Cabinet Units:

www.siemens.com/sinamics-s150

The drives family SINAMICS:

www.siemens.com/sinamics

Integrated Drive Systems:

www.siemens.com/ids

Partners worldwide:

www.siemens.com/automation/partner

Security information

Siemens provides products and solutions with industrial security functions that support the secure operation of plants, solutions, machines, equipment and/or networks. They are important components in a holistic industrial security concept. With this in mind, Siemens' products and solutions undergo continuous development. Siemens recommends strongly that you regularly check for product updates.

For the secure operation of Siemens products and solutions, it is necessary to take suitable preventive action (e.g. cell protection concept) and integrate each component into a holistic, state-of-the-art industrial security concept. Third-party products that may be in use should also be considered. For more information about industrial security, visit

www.siemens.com/industrialsecurity

To stay informed about product updates as they occur, sign up for a product-specific newsletter. For more information, visit

<https://support.industry.siemens.com>

Siemens AG
Process Industries and Drives
Large Drives
Postfach 47 43
90025 NUERNBERG
GERMANY

Subject to change without prior notice
PDF (E86060-K5521-A131-A5-7600)
V6.MKKATA.LDT.111
KG 0316 420 En
Produced in Germany
© Siemens AG 2016

The information provided in this catalog contains merely general descriptions or characteristics of performance which in case of actual use do not always apply as described or which may change as a result of further development of the products. An obligation to provide the respective characteristics shall only exist if expressly agreed in the terms of contract. Availability and technical specifications are subject to change without notice.

All product designations may be trademarks or product names of Siemens AG or supplier companies whose use by third parties for their own purposes could violate the rights of the owners.